

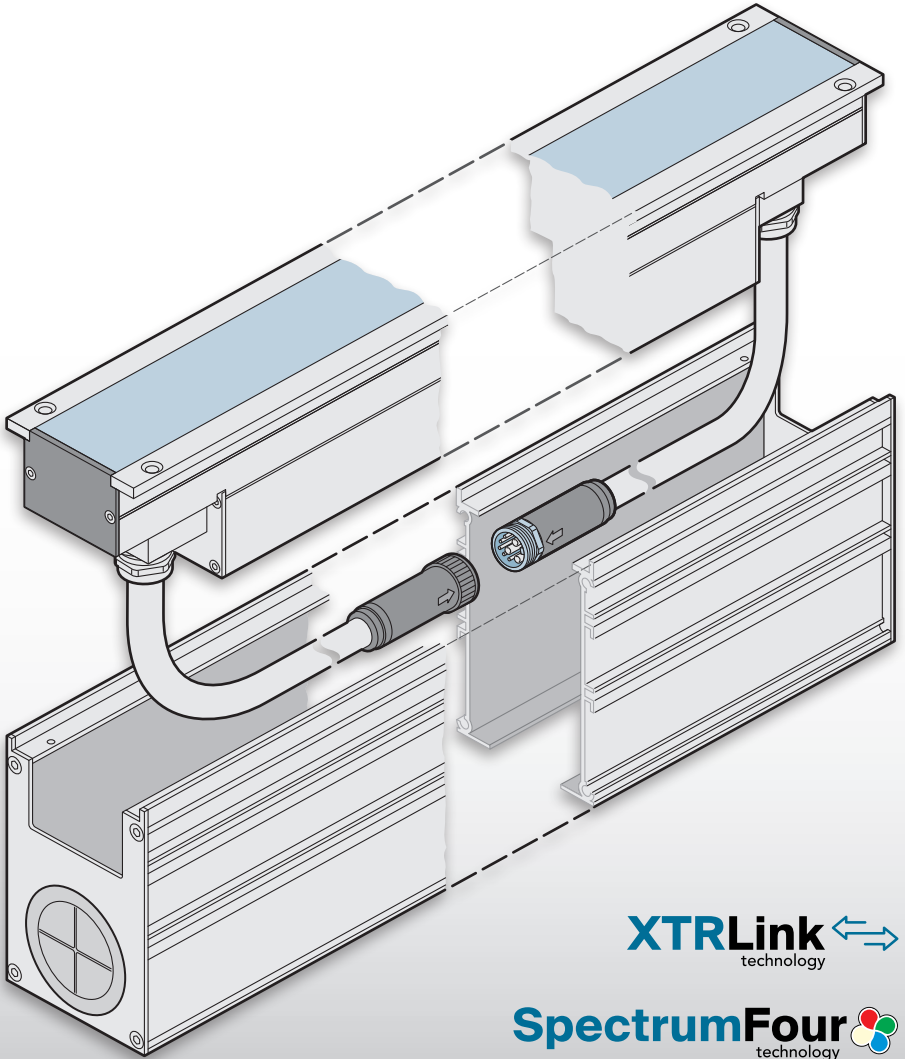

Acclaim™



XTRLink ↔
technology

SpectrumFour 
technology

Terra Linear™

User guide

Contents

Introduction.....	2
Welcome	2
Safety, maintenance and cleaning	2
Supplied items	3
Required accessories	3
Optional accessories	4
Installation.....	5
Mounting	5
Surface preparation and drainage	6
Mounting height	6
In-ground installation	7
Power	11
Interconnecting	12
Termination	12
Linking to an XTR Driver	13
Feed wiring protection: AJBOX1	14
Feed wiring protection: AJBOX1-Extended	15
Flexible power options	17
Run lengths - fixture maximum	18
Run lengths - overall maximum	18
Important cabling considerations	19
Control	20
DMX control considerations	21
Tips for achieving successful DMX control	22
Innovations to enable long runs	23
Optional wireless control	23
Operation.....	24
Addressing fixtures	24
DMX cell addressing	25
Setting the DMX personality	26
DMX channels	26
Further information.....	27
Troubleshooting	27
Specifications	28
Dimensions	29
Limited product warranty	35

Introduction

Welcome

Welcome to the Terra Linear™ range from Acclaim Lighting. These tough, drive-over ready fixtures are designed for all-weather in-ground applications. Available in 1 foot and 4 foot lengths, these aluminum-bodied IP68 fixtures are particularly suited to recessed façade lighting applications. A wide range of emitter, beam angle and power options make it straightforward to match each unit to the specific requirements of your installation.

Using unified power and DMX control links, Terra Linear fixtures can be rapidly daisy-chained in long runs. All standard mains voltages are directly supported or, to achieve impressive single runs up to 700 linear feet (213m), Terra Linear can be driven by Acclaim Lighting's XTR Driver.

Control is achieved using the industry standard DMX-512A format, with RDM for configuration. DALI and 0-10V control inputs can also be used when an XTR Driver or optional converters are employed.

Safety

- When fixtures are mounted off-ground, ensure they are securely fitted to an appropriate mounting surface.
- Ensure that the power input is supplied from an environmentally protected location, is correctly fused and has a **valid protective earth that is tied to true earth**.



HIGH VOLTAGE

WARNING - HIGH VOLTAGE

This device can use high voltages (up to 400VDC) which could cause severe personal injury or death if misused:

- **Always** isolate power before connecting or disconnecting links.
- Installation to be carried out by **certified electricians** only.
- Use only **approved** cables and connectors.
- Check all connections are correctly made **before** energizing.

Maintenance

CAUTION: Always isolate mains power before starting maintenance operations.

- Ensure that all mounting (and device) screws/bolts are fully tight and free of corrosion.
- Ensure there is no deformation to the housing, lenses or fixing points.
- Check that all power supply cables are free from physical damage or material fatigue.
- Use only genuine spare parts supplied by Acclaim Lighting.

Cleaning

- Use a moist, lint-free cloth along with warm water when cleaning each fixture.
- Never use alcohol or solvents.

Supplied items

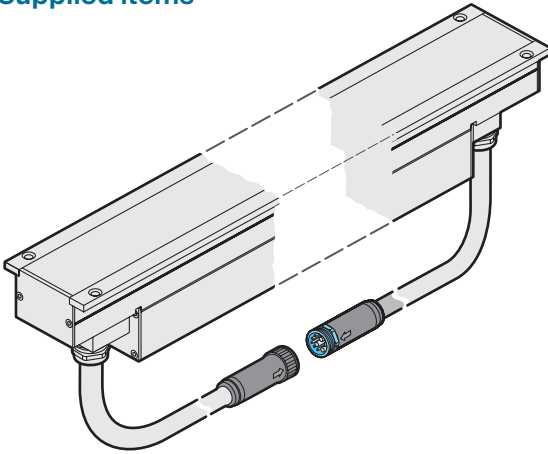

For dimensions of all items, please see page 29.

Terra Linear 1' or 4'

Required accessories

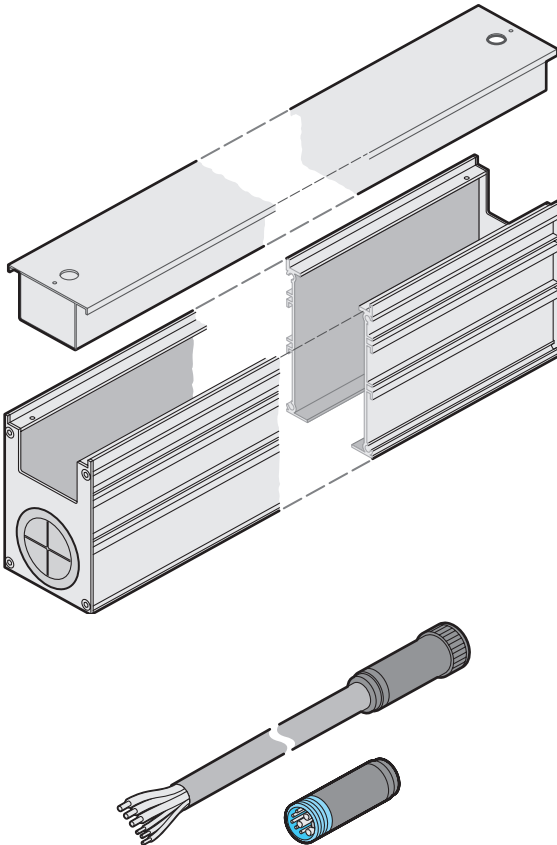

In-ground sleeve plus removable pour cover

1'	[TLAIGS1]
4'	[TLAIGS4]

Feed cables

<i>(incl terminator end cap)</i>	
10' (3m)	[TLAFC10]
50' (15m)	[TLAFC50]

continued

Optional accessories

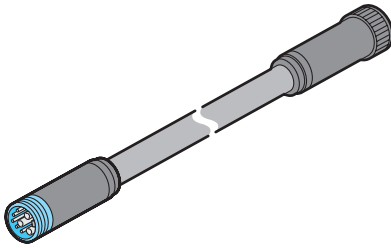

Link cables

- 1' (30cm) [TLALC1]
- 5' (1.5m) [TLALC5]
- 10' (3m) [TLALC10]

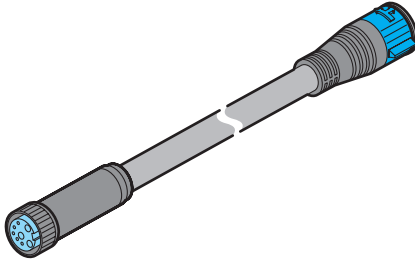

XTR Driver adapter cable

(allows a Terra Linear link cable to be connected to an XTR Driver output)

[TLAXTRC1]

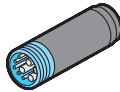

Terminator (end cap)

[TLATEC]

Round IP66 junction box plus outlet cable gland
AJBOX1

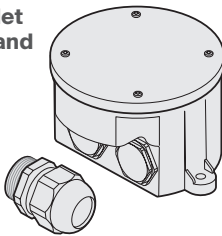

Large IP66 junction box with DMX pass-thru plus outlet cable gland
AJBOX1E

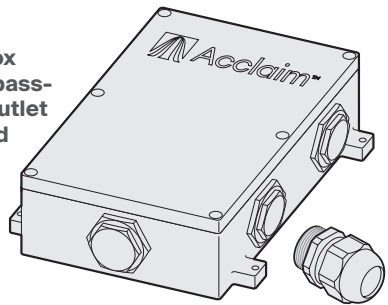

Installation

Mounting

For each Terra Linear fixture, an in-ground aluminum sleeve of the same length is required (see page 3 for part codes and page 29 for dimensions). Sleeves feature a removable 2" rubber knockout at each end as well as an aluminum pour cover along the upper surface, which fully protects the internal chamber while surface work is in progress.

IMPORTANT: To achieve a full 6000 lbs (2,721kg) drive-over rating, the long sides of each sleeve must be fully supported on 8" (203mm) concrete. Otherwise the fixture must be reduced to a walk-over rating of 2000 lbs (907kg).

To achieve a full 6000 lbs drive-over rating

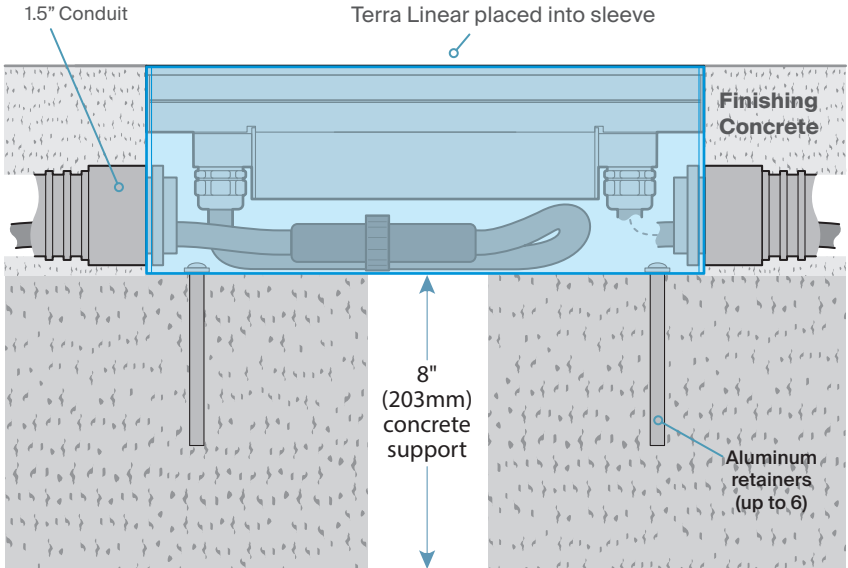

Soft ground base - 2000 lbs walk-over rating

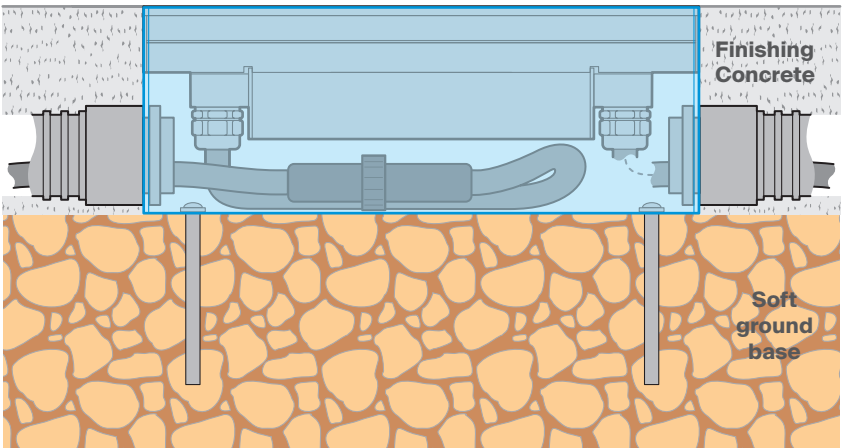

Surface preparation and drainage

Correct surface preparation is essential to ensure that the required walk- or drive-over rating is achieved (see page 5), as well as sufficient drainage to prevent permanent flooding of the chamber(s).

Each sleeve should be mounted into a level surface that is free draining, such as a permeable stone/gravel mix. If the base is concrete then suitable drainage holes should be created.

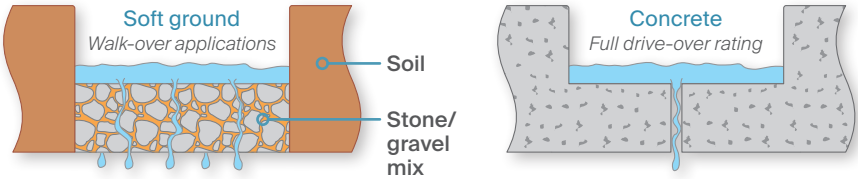

The following minimum drainage rates should be met or exceeded:

Sleeve length	Sleeve volume	Minimum drainage rate
1ft	0.6 gallons (2.7 liters)	0.022 gallons per minute (0.1 liters per minute)
4ft	2.4 gallons (10.9 liters)	0.09 gallons per minute (0.4 liters per minute)

Where drainage rates are insufficient, further measures should be employed, such as a French drain below the immediate mounting surface of each sleeve.

Mounting height

IMPORTANT: For walk- and drive-over installations, the long sides of the sleeve must be fully supported and the sleeve height must be arranged to ensure that its top edge is exactly level with the finished surface:

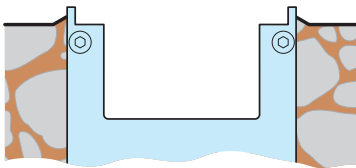

Sleeve too high



Sleeve too low

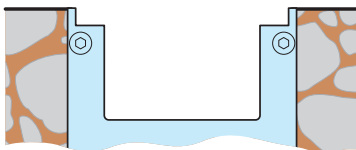

Sleeve level with surface

In-ground installation

The following section provides a brief overview of the recommended steps required to successfully install a Terra Linear fixture.

To install a Terra Linear fixture

1 Prepare the mounting location(s) - see "Mounting" on page 5.

2 Remove the pour cover from the sleeve as well as one or both of the 2" rubber knockout(s).

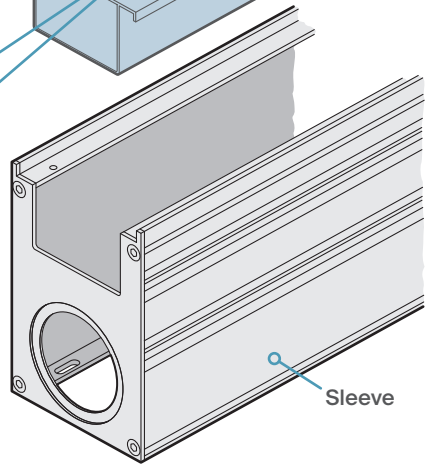
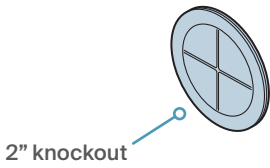
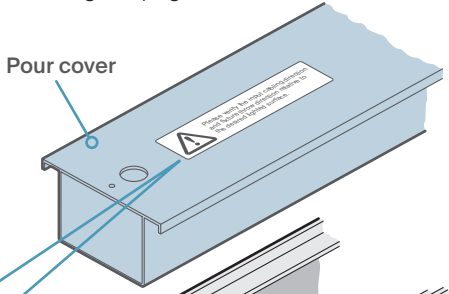
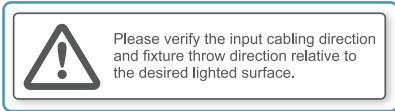

3 Lay the sleeve in place and use up to six retainers (by others) suitable to the mounting surface to prevent movement. The retainers should be aluminum to prevent galvanic corrosion and 6" (150mm) in length or longer.

Six mounting slots can accommodate retainers up to 3/16" (4mm) in diameter

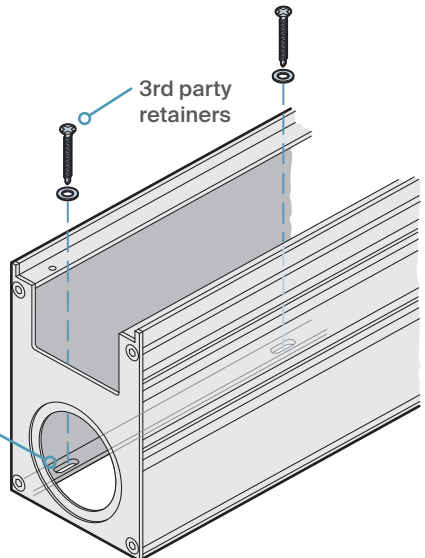

4 Attach a suitable 1.5" conduit (by others) to the inlet hole and lock it in place.

Repeat for the outlet hole, if required.

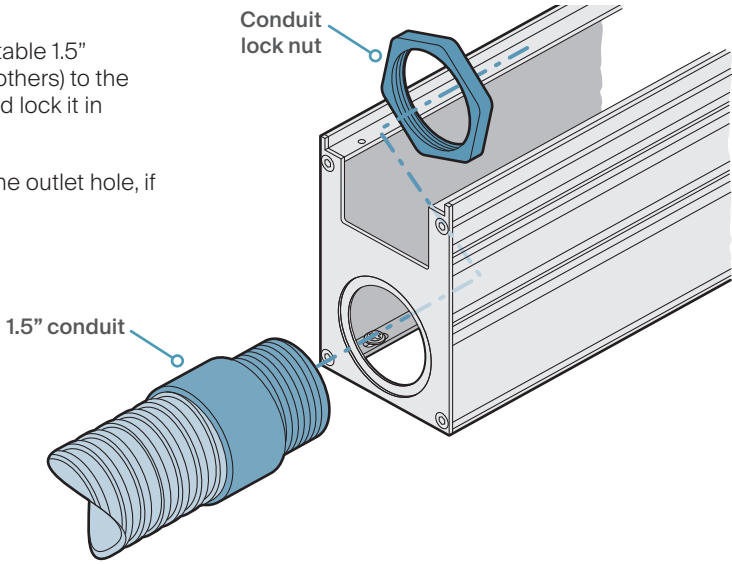

- Where sleeves are abutted, use suitable 1.5" conduit couplers to secure the joins.

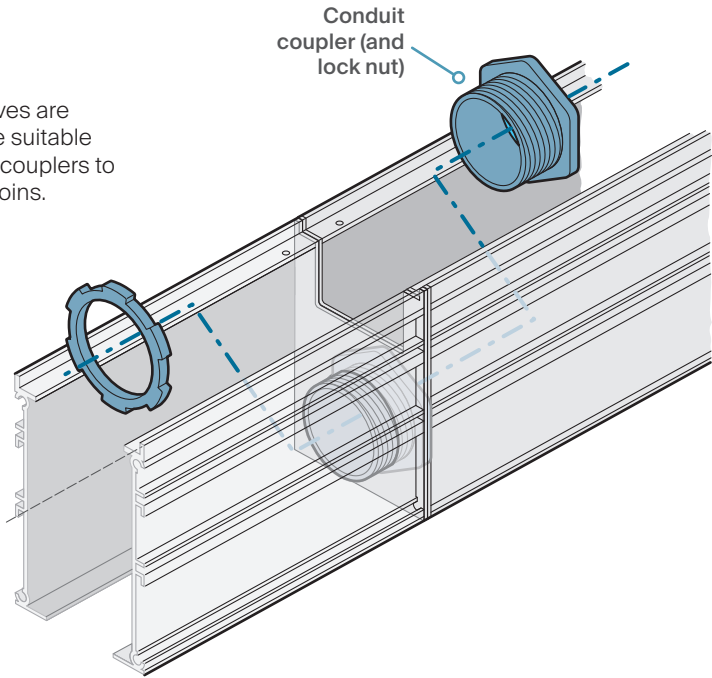

- 5 Run the link cables through the conduit into the sleeve chamber (using a draw wire if necessary).
- 6 If possible, test the connections before the final surface is laid.

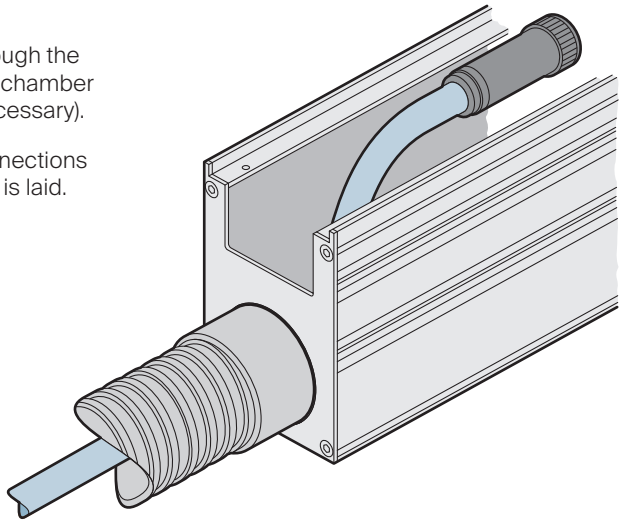

- 7 Prior to surfacing, replace the supplied pour cover onto the sleeve to prevent concrete entering the chamber. **Tape over the holes in the pour cover.**

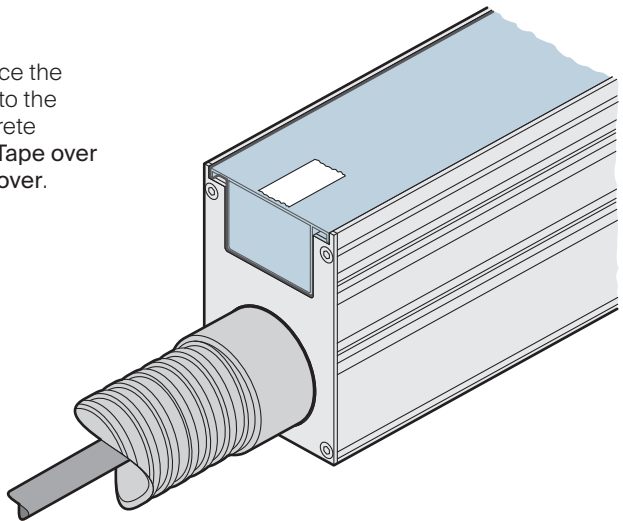

8 Once the finished surface has been applied, carefully remove the pour cover to reveal the chamber.

9 Set the Terra Linear fixture near the sleeve and connect the cables.

Note: When attaching cables and/or termination end cap, ensure the connectors are correctly mated and fully locked to prevent water penetration. Failure to do so may invalidate the warranty. See page 12.

10 Carefully fold the cables into the chamber as the Terra Linear is lowered. The 1ft sleeve in particular is a tight fit.

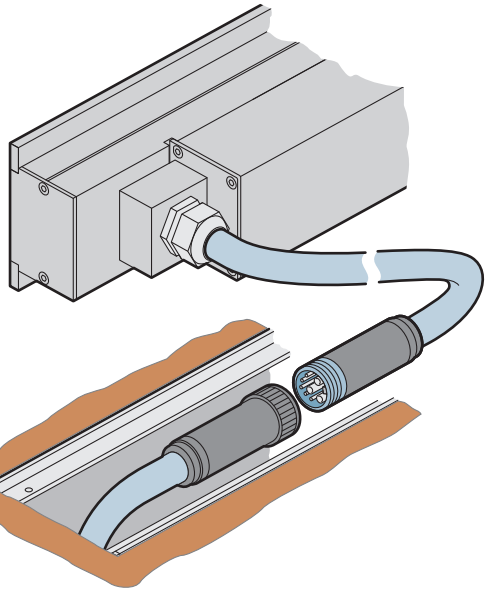

11 Insert the supplied bolts and tighten using a Torx T20 security driver (not supplied).

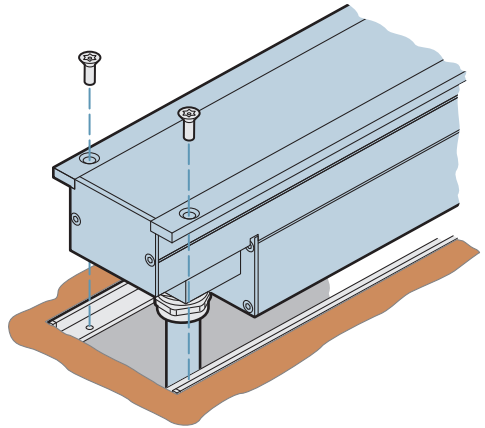

Power

Power and control are combined within the IP66-rated feed and link cables using a proprietary design. Neighboring units can be directly connected without need for extra cables.

The color designations for the optional feed cable are as follows:

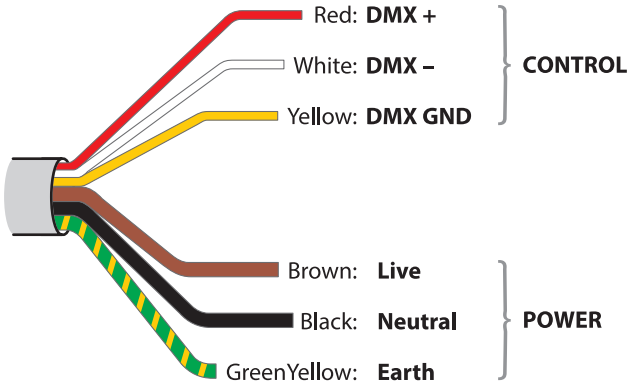

Control cores: 24 AWG / 0.25mm²

Power cores: 14 AWG / 2.5mm²

IMPORTANT: Ensure that power earth and DMX GND are both tied to true earth.

Always follow these steps when using Terra Linear cabling:

- **Ensure that the power input is isolated from the mains supply.**
- At each connection, remove the cover caps from both the socket and plug.
- Align the orientation marks of the socket and plug, then push them together and twist the locking collar to lock them fully together.
- Do not exceed the stated maximum fixtures in a daisy chain - see page 18.
- **At the final fixture in a daisy-chain run, install a terminator (end cap) to seal off the power bus and also correctly terminate the DMX control feed (see page 12).**
- To release a connection, ensure that the power input is isolated, then twist the locking collar to release the connection.



Interconnecting

Terra Linear fixtures have two 18" (450mm) composite power/control leads - an input at one end and a output at the other. Fixtures can be directly daisy-chained or alternatively an optional link cable can be used between any two fixtures to make up a gap.

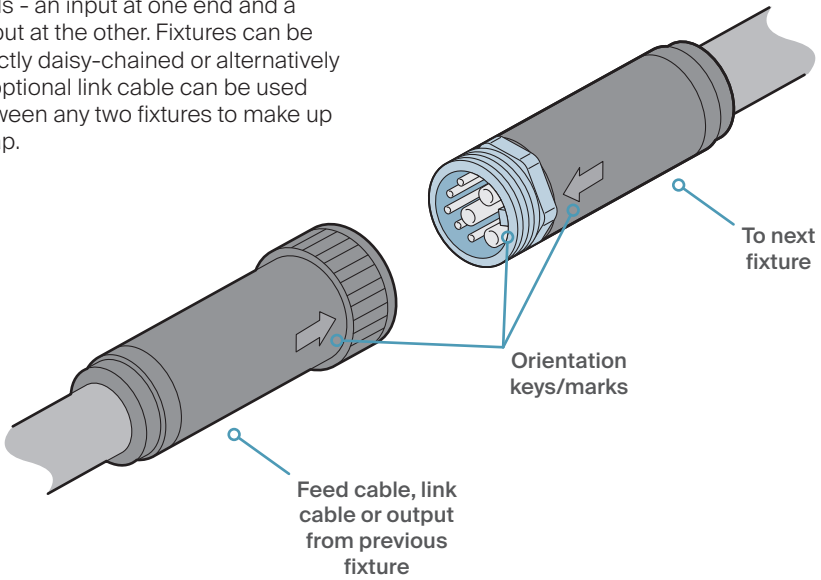

Termination

It is important that the final fixture in a run is correctly terminated using a terminator/end cap (see page 4). This ensures that:

- The DMX signals are correctly terminated, and
- The power bus is safely sealed off.

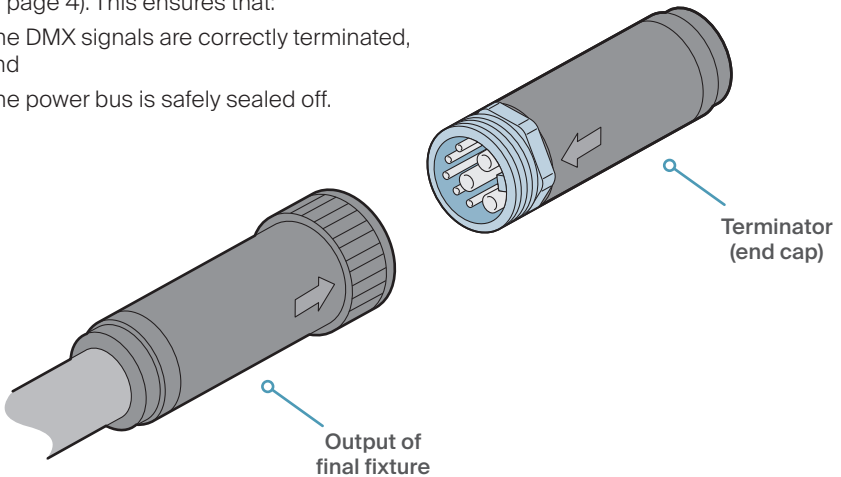

Linking to an XTR Driver

Terra Linear fixtures can operate directly from standard AC mains voltages (100 to 277VAC) or alternatively can be connected to an Acclaim Lighting XTR Driver, enabling even longer runs. Use an optional XTR Driver adapter cable (see page 4) to convert from XTR output to Terra Linear input:

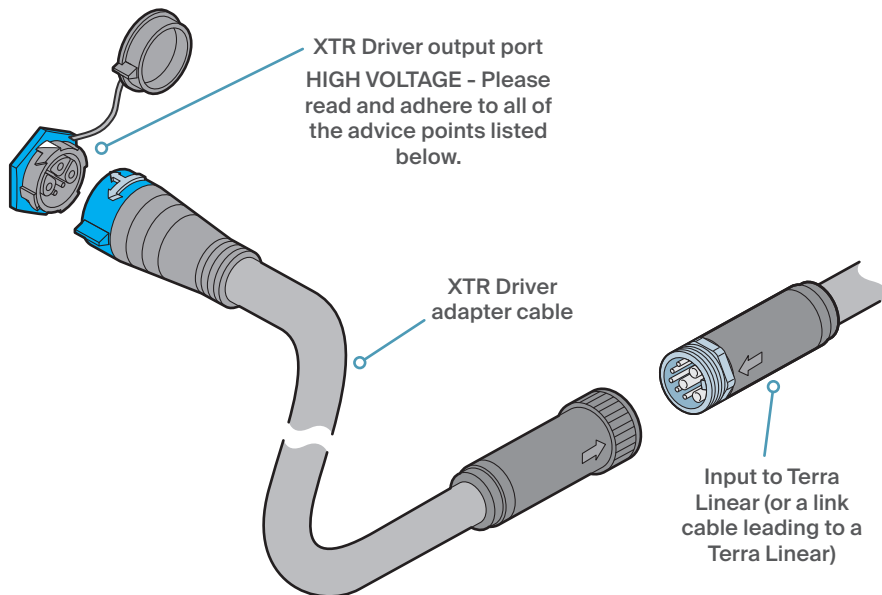

HIGH VOLTAGE

WARNING - HIGH VOLTAGE

This device can use high voltages (up to 400VDC) which could cause severe personal injury or death if misused:

- **Always** isolate power before connecting or disconnecting links.
- Installation to be carried out by **certified electricians** only.
- Use only **approved** cables and connectors.
- Check all connections are correctly made **before** energizing.

Always follow these steps when using XTR cabling:

- **Ensure that the power input is isolated from the mains supply.**
- At each connection, release the cover caps from both the socket and plug.
- Align the orientation marks of the socket and plug - and then push them together so that the blue lock ring clicks fully into place.
- As each connection is made, ensure that the connector is fully locked onto the socket.
- **Any unused output ports must have their cover cap securely fixed in place.**
- Do not exceed the stated maximum fixtures in a daisy chain - see page 18.
- **At the final fixture in a daisy-chain run, install an End Cap (see page 4) to seal off the power bus and also correctly terminate the DMX control feed.**
- To release a connection, ensure that the power input is isolated, then twist the blue lock ring of the plug counter-clockwise to release the connection.



Feed wiring protection: AJBOX1

The Acclaim Lighting AJBOX1 is a compact IP66-rated junction box, which provides separated AC power and DMX control inputs for connection to a combined feed cable. Internal surge protection up to 10kV max is built-in. The Terra Linear feed cable connections should be arranged on the internal connector blocks as shown here. The separate power and control input connections can be made on the other side of these connector blocks.

IMPORTANT: The AJBOX1 is rated for maximum voltages up to 277VAC. Do not use AJBOX1 to connect XTR high voltage links.

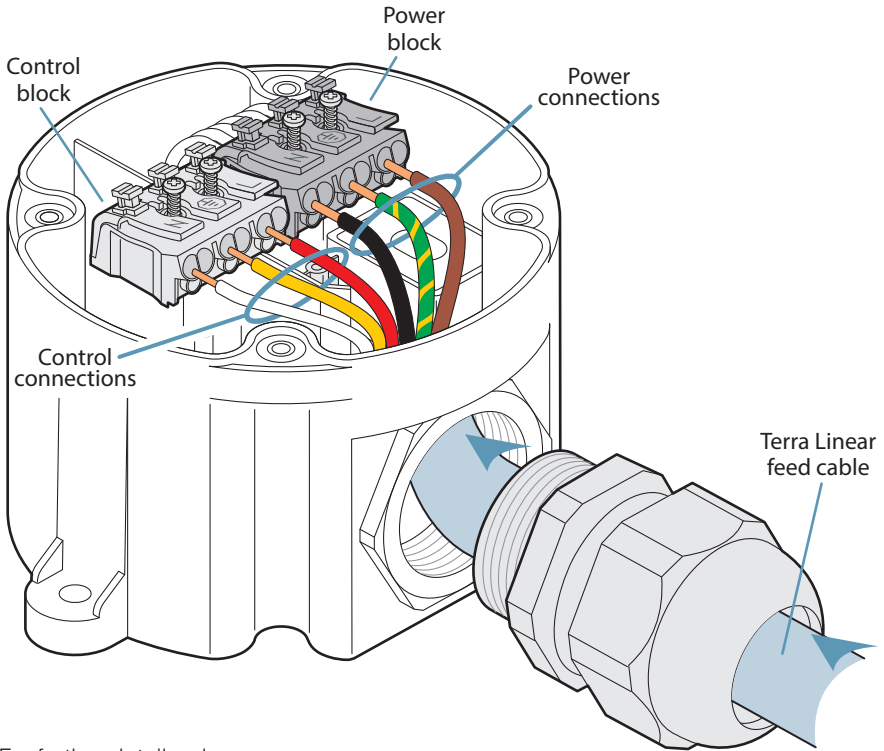

For further details, please see:

- Page 11 for wire colors.
- Acclaim Lighting AJBOX1 user guide (<https://acclaimlighting.com/products/ajbox1>).

Feed wiring protection: AJBOX1-Extended

The Acclaim Lighting AJBOX1 Extended is a metal-bodied IP66-rated junction box, which provides separated AC power and DMX control inputs for connection to a combined feed cable or multiple outputs. Internal surge protection up to 10kV max is built-in as well as full optical signal isolation for the control data.

IMPORTANT: The AJBOX1 Extended is rated for maximum voltages up to 277VAC. Do not use to connect XTR high voltage links.

- 1 Remove the lid by removing the six recessed bolts using a 1/8" (3mm) hex key:

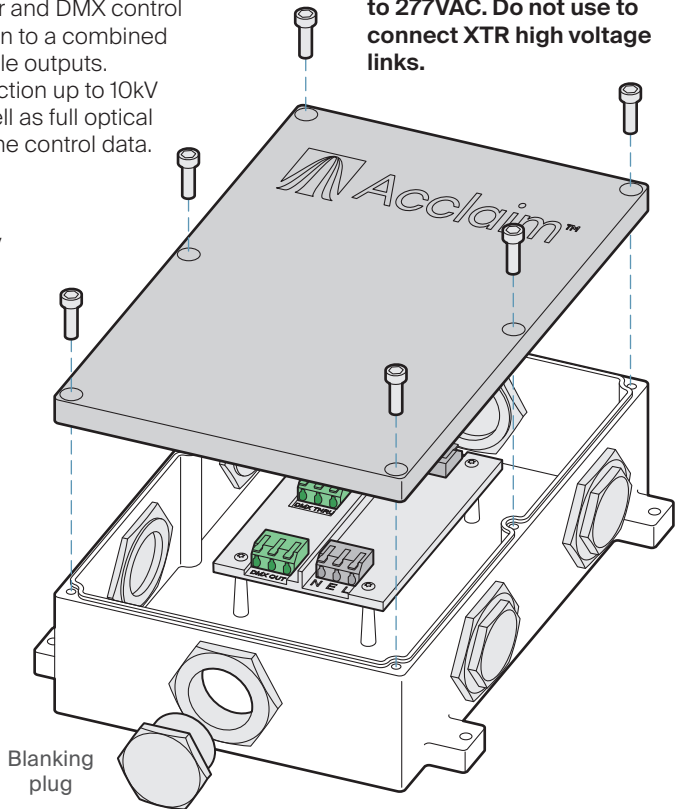

- 2 Remove blanking plugs, as required, using a 1 1/16" (30mm) spanner.
- 3 If required, gently prise off the rubber seals from the blanking plugs using a small flat blade screwdriver in order to install them on the cable glands/conduit fittings that you're using:

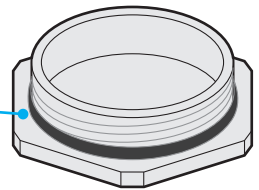

- 4 Add cable gland(s) or conduit fitting(s) as required (3/4" NPT thread):
- 5 Feed in your power and DMX inputs, plus the Terra Linear feed cable.

Cable glands or conduit fittings (by others)

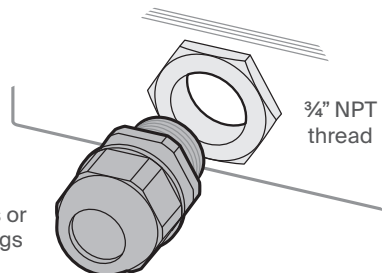

6 Connect your DMX control lines:

- Attach your control input to the green **DMX In** connector block.
- Optionally use the green **DMX Thru** connector block to continue your control run to other local devices. *Note: These contacts are directly linked to the DMX In connector block, they are NOT isolated.*
- Attach your main control output line to the green **DMX Out** connector block. These contacts are optically and galvanically isolated from the DMX In/Thru contacts while permitting DMX signals up to a full 44 frames per second to pass. *Note: RDM is not supported.*

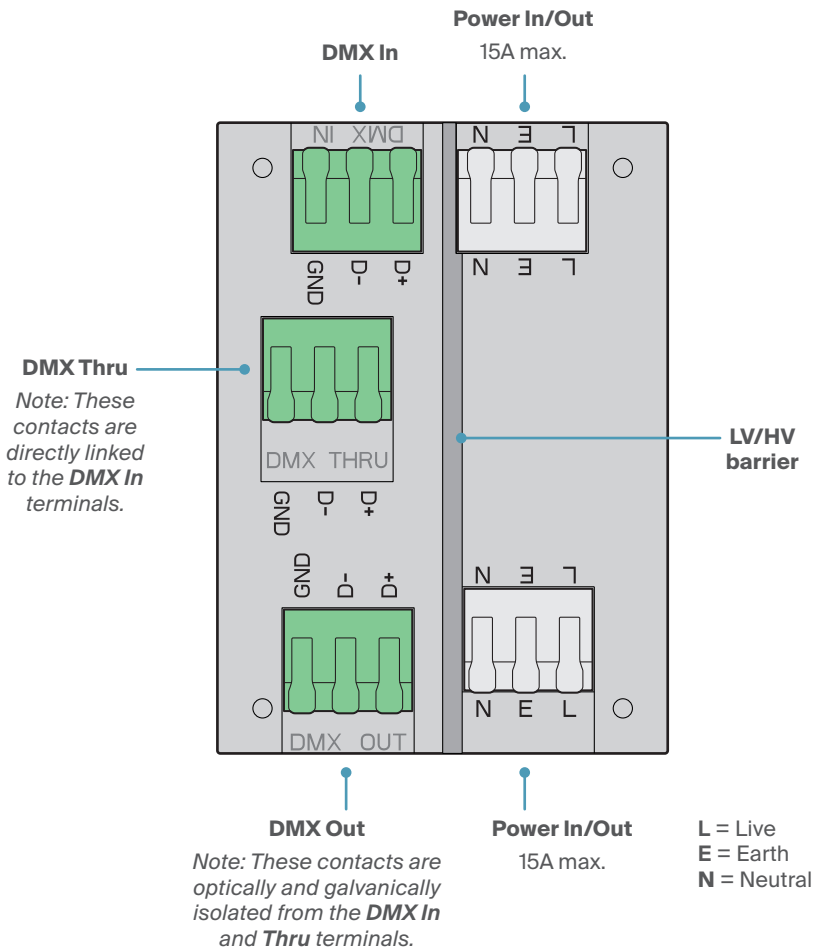

- 7 Connect a mains input to either of the two gray power connector blocks. A power input of 100–277VAC (50/60Hz) is required to energize the DMX isolation circuitry.
- 8 If required, connect a power output cable to the other gray connector. A maximum of 15A can pass between the two power connectors.
- 9 Refit and tighten the lid, while ensuring the lid's rubber seal is correctly in place.

Flexible power options

Terra Linear fixtures support two different power options:

Standard mains supply

Using a feed cable, one or more Terra Linear fixtures can be powered directly from a standard mains supply, ranging from 100 to 277VAC (50/60Hz).

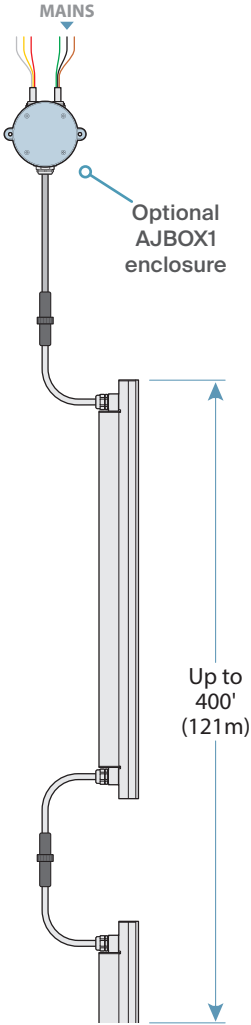

XTR Driver supply

An optional XTR Driver 4000 or XTR Driver 8000 can be used to create a special high voltage supply (380VDC) in order to achieve greatly increased fixture run lengths.

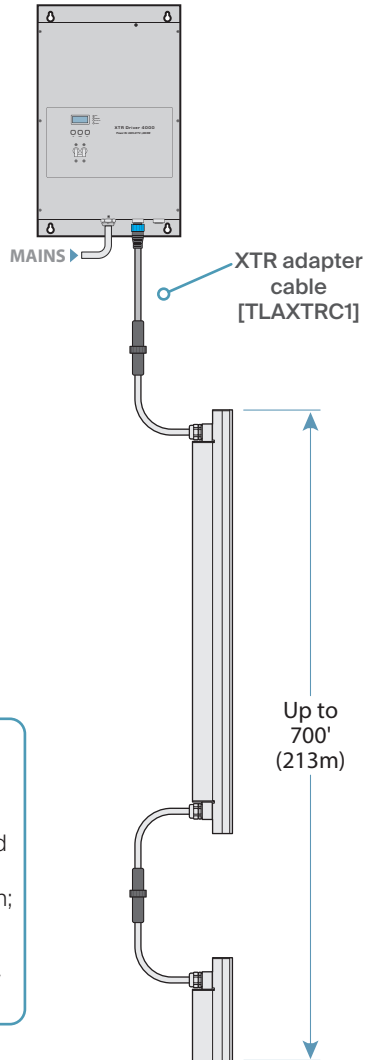

Note:
Terra Linear fixtures can use either power method without any reconfiguration; voltage levels are automatically detected.

Please see page 18 for further details about run lengths.

Run lengths - fixture maximum

The maximum number of fixtures that can be driven in a single run is determined by the supply voltage and the collective power requirements for the fixtures. The maximum total lengths listed here can be formed from any combination of 1' or 4' fixtures. Fixtures with differing LED color options can be mixed freely as they all adhere to the same power specifications (within their LO/EO/CO/SO/HO types).

Model	Power draw	100VAC 120VAC	230VAC 277VAC	XTR Driver 4000	XTR Driver 8000
LO	(2.5W/ft)	200' (61m)	400' (122m)	700' (213m)	2x 700' (213m)
EO	(5W/ft)	200' (61m)	400' (122m)	700' (213m)	2x 700' (213m)
CO	(7W/ft)	150' (45m)	300' (91.5m)	500' (152m)	2x 500' (152m)
SO	(12W/ft)	100' (30.5m)	200' (61m)	300' (91.5m)	2x 300' (91.5m)
HO	(20W/ft)	50' (15m)	100' (30.5m)	150' (45m)	2x 150' (45m)

Run lengths - overall maximum

In addition to remaining within the maximum permitted length of *fixtures* in a single run (as discussed above), you also need to adhere to the working limits for the overall length of the **whole installation**, ie the total length fixtures in the run **plus** all their additional feed and link cabling, as listed below.

Note: These limits are imposed only by the power characteristics. The length of the DMX control feed to the first XTR fixture could potentially be up to the usual DMX standard limit (3,900 feet/1200m) with appropriate cable choice, although Acclaim Lighting recommends a maximum DMX / RDM run of 1,500' (457m) without buffering (see 'Important cabling considerations' on page 19 and "Tips for achieving successful DMX control" on page 22).

Supply voltage	Maximum overall run length (fixtures plus all extra cabling)
100/120VAC (10A max)	200' (61m)
230/277VAC (10A max)	400' (122m)
380VDC (XTR Driver)	800' (243m)

IMPORTANT: Ensure the voltage drop across the entire run does not exceed 9%.

Important cabling considerations

During installation, protection of the cabling must always be fully considered:

- Wherever possible, above grade cable runs should be positioned to make them beyond normal reach within any installation.
- For long above grade cable runs, external runs and in areas where public contact and/or accidental damage is possible, the cabling should be contained within protective conduit. Minimum spec: Schedule 40, 1.5" (ID: Ø1.61", OD: Ø1.74").
- Additional power cabling: Where power feeds require the use of third party cabling, the power cores should be 14 AWG minimum.
- Additional DMX control cabling: For initial control runs leading to the Terra Linear run, these are recommended:
 - Indoor exposed or inside conduit above grade: Belden 9842
 - Indoor plenum: Belden 82842
 - Outdoor exposed, direct burial, or inside conduit below grade: Belden 3107DB
- Ensure that:
 - The mains input is derived from a suitable overload-protected supply.
 - All cable access points, plus the enclosure cover are correctly sealed.
 - All local codes are followed during planning and installation.
 - Connections are made, inspected and certified by a qualified electrician.

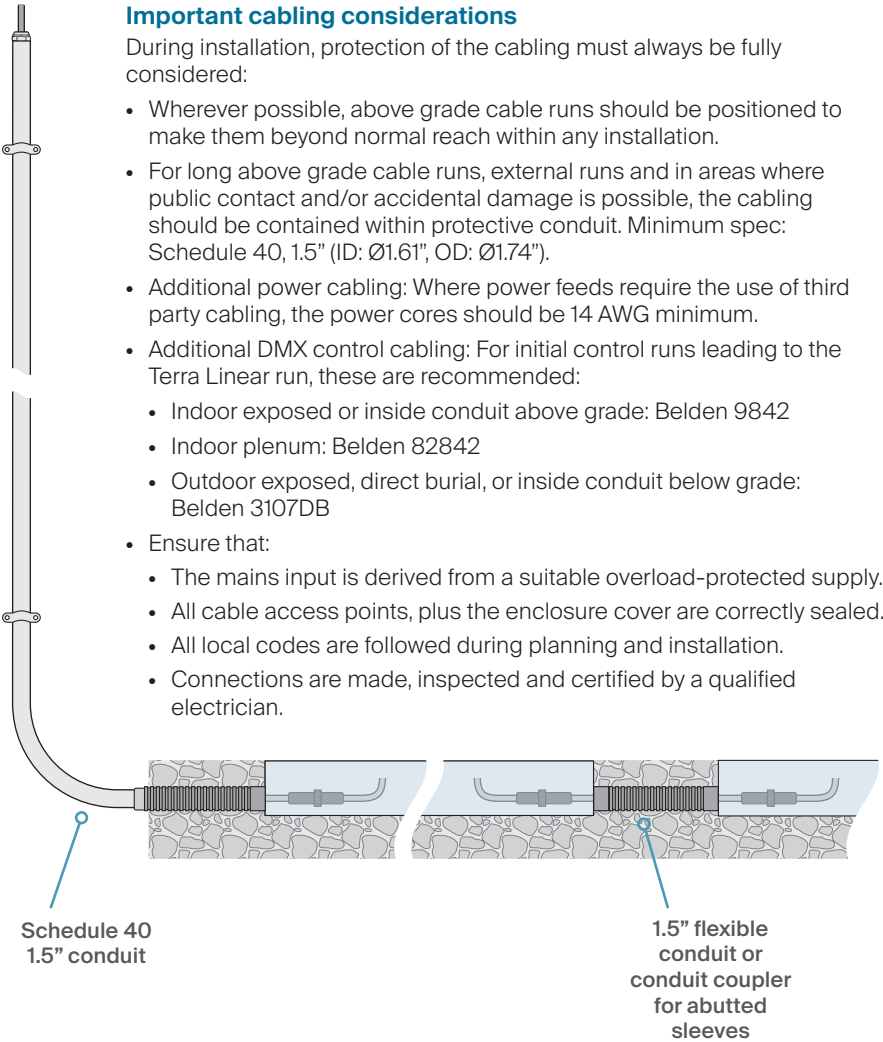

Control

Terra Linear fixtures use DMX as their native control method, however, it is possible to use other common control protocols when required, such as 0-10V (source or sink) or DALI.

Control inputs via converters

- DMX - connect a DMX input directly into the feed cable.
- 0-10V - use an Acclaim Lighting ZDM 6 (or similar) to convert one or more analog control feeds into a combined DMX feed¹.
- DALI - use an Acclaim Lighting DDC-1-AC (or similar) to convert one or more DALI channels into a combined DMX feed¹.

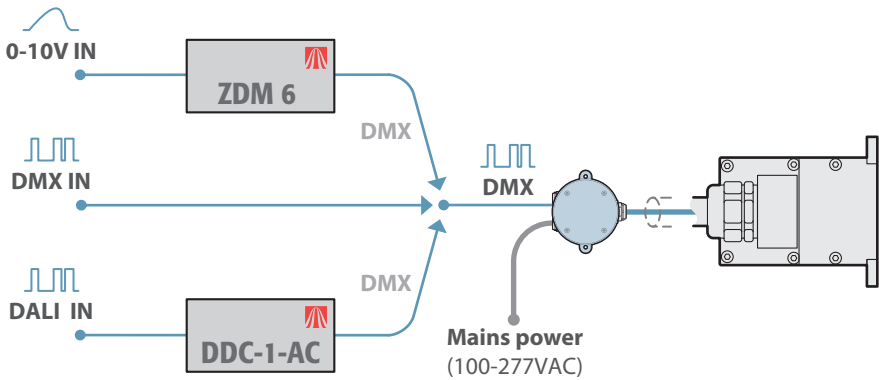

Control inputs via an XTR Driver

The XTR Driver 4000 and 8000 units can accept DMX, 0-10V or DALI control inputs directly. The latter two methods are converted within the driver² before being transmitted as DMX within the consolidated output, together with the high voltage XTR power.

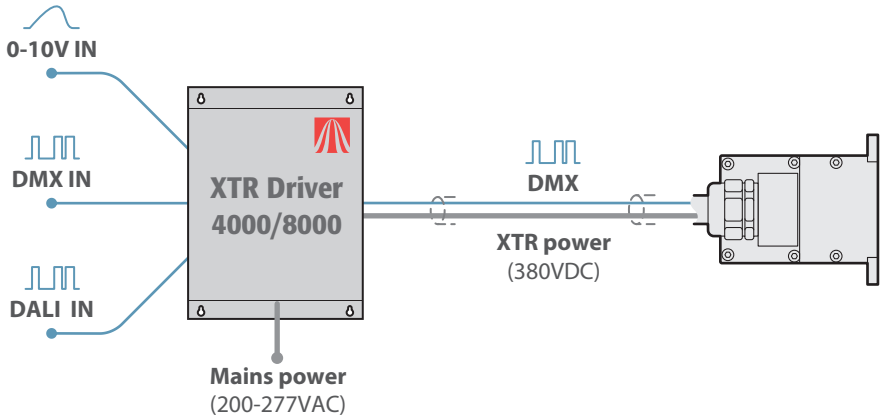

Notes:

¹ When using Acclaim Lighting ZDM 6 or DDC-1-AC modules it is possible to convert up to six 0-10V feeds or up to 64 DALI channels into separate DMX channels within a consolidated feed - thus allowing multiple Terra Linear fixtures to be uniquely addressed.

² When using an XTR Driver, the internal conversion supports either a single 0-10V feed or a single 'broadcast' DALI channel - meaning that all Terra Linear fixtures will use the same single control address. To benefit from multiple channels, use a ZDM 6 or DDC-1-AC to externally convert signals.

DMX control considerations

The maximum number of fixtures that can be uniquely addressed in a run is determined by the length, emitter type and operation mode (see page 26) of each linear fixture, as summarized in the tables below. Additionally, any number of fixtures can be configured to use duplicate control addresses, as required.

1' (305mm) Terra Linear

Emitter options	DMX channels used				Total channels per fixture	Maximum unique fixtures
	▶ Cell 1					
W	1				1	512
DW	2				2	256
RGBW/A	4				4	128

4' (1220mm) Terra Linear (operating in '1 Group' mode)

Emitter options	DMX channels used				Total channels per fixture	Maximum unique fixtures
	▶ All cells combined					
W	1				1	512
DW	2				2	256
RGBW/A	4				4	128

4' (1220mm) Terra Linear (operating in '4 Group' mode)

Emitter options	DMX channels used				Total channels per fixture	Maximum unique fixtures
	▶ Cell 1	Cell 2	Cell 3	Cell 4		
W	1	1	1	1	4	128
DW	2	2	2	2	8	64
RGBW/A	4	4	4	4	16	32

Tips for achieving successful DMX control

- Acclaim Lighting recommends a maximum DMX / RDM run of 1,500' (457m) without buffering.
- Attach an end cap [Part #: TLAEC] to the output connector of the final fixture. The end cap will correctly terminate the DMX signal (and will also safely seal off the power bus).
- The DMX cable connected to the feed cable should be suited for RS-485 data transmission and have a characteristic impedance of 120 ohms, such as Belden 9842 or equivalent.
- Do not introduce a passive Y-split into the control cabling. If it is necessary to split the control link in order feed fixtures located in different directions, use a powered DMX splitter such as the Acclaim Lighting RDS 6: <https://acclaimlighting.com/rds-6>
- Ensure that the DMX + and DMX - connections do not become crossed at any point.

DMX Cable selection

We recommend the following Belden signal cables:

- Indoor exposed or inside conduit above grade:Belden 9842
- Indoor plenum:Belden 82842
- Outdoor exposed, direct burial, or inside conduit below grade: .Belden 3107DB

Suitable alternative cables must meet all of the following requirements:

- Construction: Shielded, twisted pair (or multi-pair).
- Impedance: Between 90 and 120Ω.
- Capacitance: 15pF or less.

Innovations to enable long runs

There are numerous challenges involved with creating long runs of high output LED fixtures, most notably concerning control and power; in response, Acclaim Lighting engineers have created ingenious solutions to ensure consistent and reliable operation:

Control

Long distances and high fixture counts are detrimental even to such a robust control solution as DMX; usually a maximum of 32 fixtures is possible before the signal-to-noise ratio threatens to affect operation. That is why Terra Linear fixtures act as their own signal isolator and conditioner before passing the control feed down the line. The result is a clean, reliable and [still] industry-standard control solution right to the end of the line. Additionally, as each fixture supports RDM, the passage of conditioned and isolated signals is fully bi-directional.

Power

Every Terra Linear fixture conditions its own power using a high-efficiency internal switched-mode power supply. A well known feature of such devices is their behavior during the fractions of a second after power is first applied, known as 'in-rush current'. This is when their internal components top themselves up with charge to progress from empty to a working state, which causes a very brief rise above their usual maximum consumption level. If you place many such devices on the same power line and activate them all simultaneously, their collective temporary overruns can easily swamp an otherwise perfectly adequate power feed, causing breaker trips.

To reliably solve this issue, the common high voltage power rail running through the supply cables is not a 'dumb run' but rather a managed resource. Every fixture energizes itself fully before passing power through to the next fixture in the chain. The delay at each fixture is measured in milliseconds, but it is sufficient to ensure that the installation as a whole never stresses the main power feed during the initial startup.

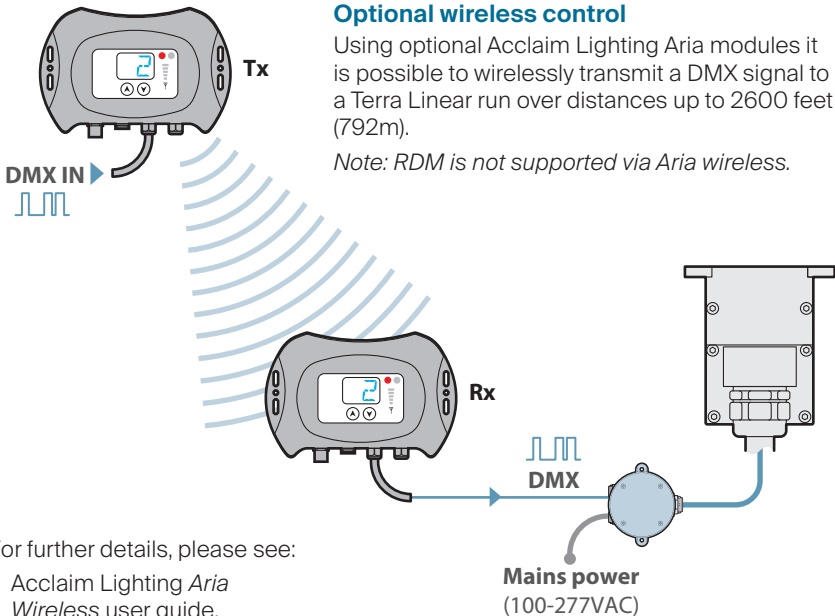

Operation

Terra Linear fixtures have no external controls and instead rely on RDM (Remote Device Management) for all configuration via the DMX interface. This allows multiple devices to be configured either before or after installation.

Addressing fixtures

To configure the DMX address using the DMXcat-E

- 1 Connect the DMXcat-E to the DMX input line of the Terra Linear installation.
- 2 In the DMXcat app on your phone, link to the DMXcat-E unit and then choose the RDM Controller tool:

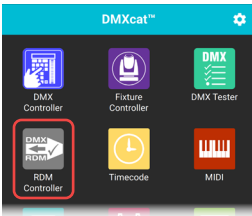

- 3 The DMXcat-E will search for RDM devices and after a short while it will display a list of all located fixtures:

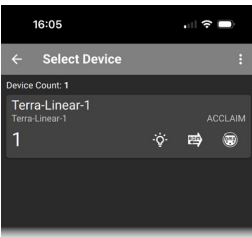

- 4 Tap the list entry for the required fixture to view the Quick Settings popup:



- 5 Tap the **DMX Address** entry, enter the required address and tap the  icon.

DMX cell addressing

The actual alignment of Terra Linear fixture cells to DMX addressing is determined by the base address (see page 24) and, for 4' models, also the chosen DMX Personality. For a fixture assigned with a start address of 1, the DMX addresses for each color of each cell are listed below. For details about choosing the DMX Personality, see page 26.

1' (305mm) Terra Linear

INPUT ▶ **Cell 1**

<i>White</i>	W: 1
<i>Dynamic White</i>	Warm: 1 Cold: 2
<i>RGBW/A</i>	R: 1 G: 2 B: 3 A / W: 4

4' (1220mm) Terra Linear (operating in '1 Group' mode)

INPUT ▶ **All cells combined**

<i>White</i>	W: 1
<i>Dynamic White</i>	Warm: 1 Cold: 2
<i>RGBW/A</i>	R: 1 G: 2 B: 3 A / W: 4

4' (1220mm) Terra Linear (operating in '4 Group' mode)

INPUT ▶ **Cell 1** | **Cell 2** | **Cell 3** | **Cell 4**

<i>White</i>	W: 1	W: 2	W: 3	W: 4
<i>Dynamic White</i>	Warm: 1 Cold: 2	Warm: 3 Cold: 4	Warm: 5 Cold: 6	Warm: 7 Cold: 8
<i>RGBW/A</i>	R: 1 G: 2 B: 3 A / W: 4	R: 5 G: 6 B: 7 A / W: 8	R: 9 G: 10 B: 11 A / W: 12	R: 13 G: 14 B: 15 A / W: 16

Setting the DMX personality

The 4' (1220mm) models offer a choice of modes that determine whether all of the emitters act as a single 4' cell or as four separate 1' cells, each with their own set of DMX addresses - see page 25.

To set the DMX personality using the DMXcat-E

1 Connect the DMXcat-E to the DMX input line of the Terra Linear installation.

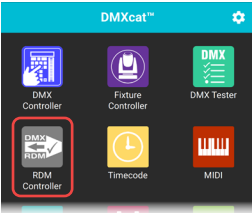

2 In the DMXcat app on your phone, link to the DMXcat-E unit and then choose the **RDM Controller** tool. The DMXcat-E will search for RDM devices and after a short while it will display a list of all located fixtures.

3 Tap the entry for the required fixture to view the Quick Settings popup. Tap the **DMX Personality** entry:

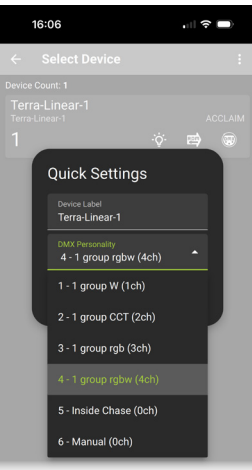

Note: You can optionally set the fixture to produce a static color or slow chase that will run whenever power is applied, either:

- **INSIDE CHASE** to set a chase, or
- **MANUAL** to set all emitters to 100%.

DMX control is ignored when in these modes.

4 Tap the required mode from the drop down list and then tap the ► icon.

- For white models, choose either **1 GROUP WHITE** or **4 GROUP WHITE**,
- For dynamic white models, choose either **1 GROUP CCT** or **4 GROUP CCT**,
- For RGBW or RGBA models, choose either **1 GROUP RGBW** or **4 GROUP RGBW**.

DMX channels

The number of channels required per fixture depends on the model and, for 4' models, also the cell mode (personality) - see page 25:

Emitter options	1' (or 4' in 1 Group mode)	4' (in 4 Group mode)
White	1	4
Dynamic white	2	8
RGBW/A	4	16

Further information

Troubleshooting

No light output is visible when expected

- Check that power is correctly applied to the fixture and that there is no damage to the power input cord.
- Use an RDM tool to perform an emitter test.
- Check that the DMX address set within the fixture matches that being output by the controlling source device.
- Check the DMX output near to the source to confirm a valid signal is being originated.
- Check that the DMX + (hot) and DMX - (cold) lines have not been crossed.
- [Fixtures with white emitters only] If no control protocol is present, white light fixtures will default to full on.

Specifications

Emitters	2700K, 3000K, 3500K, 4000K, DW (2700K-6000K), QS (W=3000K), QW4 (W=4000K) or QW6 (W=6000K)
Optics	10° x 10°, 25° x 25°, 40° x 40°, 60° x 60°, 10° x 35°, 10° x 60°, 30° x 60° or Asymmetric wall wash (60° x 60° + 20° tilt)
Lumen maintenance	L ₇₀ 150,000 hours (@ 25° C)
Control	0-100% dimming via wired DMX (with RDM configuration). 0-10V and DALI via XTR Drivers
Maximum fixtures in series	See page 18
Housing lengths	1' (305mm) or 4' (1220mm). In-ground sleeve with pour cover required (ordered separately)
Operating voltage	100-277VAC, 50/60Hz direct or 380VDC via XTR Driver 4000/8000 (200-300VAC input to XTR Driver)
Power consumption	HO: 1': 20W 4': 80W, SO: 1': 12W 4': 48W, CO: 1': 7W 4': 28W, EO: 1': 5W 4': 20W, LO: 1': 2.5W 4': 10W
Connection	Composite integral input and output cables [18" (46 cm) lengths] with IP68 multi-pin connectors
Mounting	In-ground sleeve required (ordered separately). Includes pour cover and knock-outs for 1.5" conduit
Material	Type III hard coat anodized aluminum, marine and natatorium environment ready
Finish	Finished aluminum. Anti-slip lens coatings
Ambient temperature range	-40° F to 131° F (-40° C to 55° C)
Ingress protection	IP68, wet location and temporary submersion for up to 1 hour at 3.28' (1m)
Impact protection	IK10, protection against 20 joule impact (40cm distance)
Vibration protection	ANSI C136.31, 3G-rated for high vibration and bridge applications
Drive over rating	Walk- and drive-over rated up to 6,000 lbs (2,721kg)
Weight	1': 4 lbs (1.81 kg) 4': 16 lbs (7.25 kg)
Certifications	



(ETL Listing conforms to UL 1598 : 2018 Ed. 4 standards)

Dimensions

In-ground sleeves

- 1ft (305mm) Part #: TLAIGS1
- 4ft (1220mm) Part #: TLAIGS4

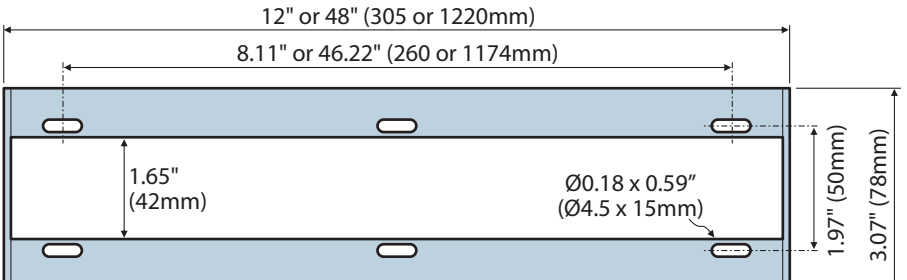
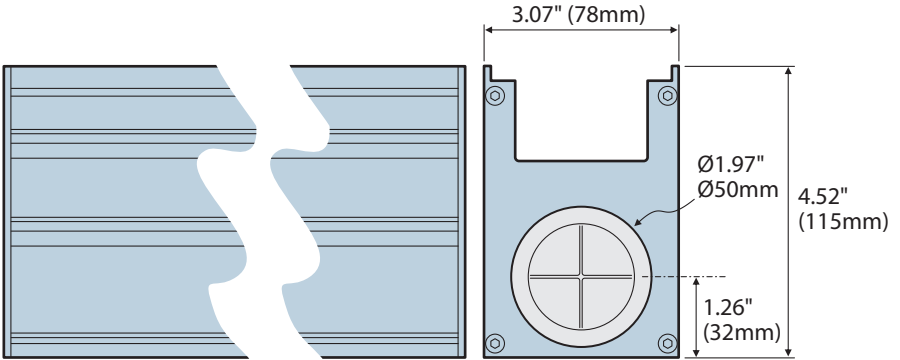
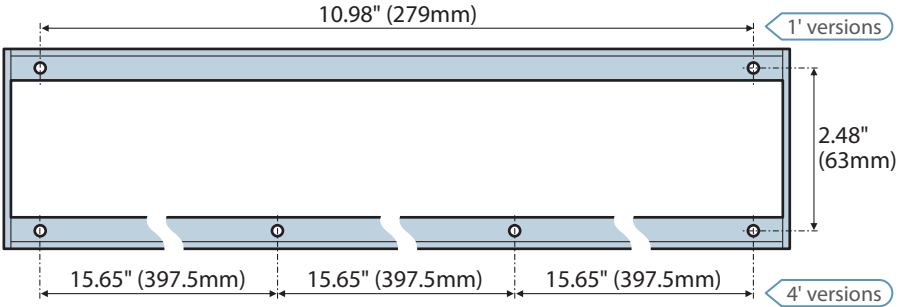

Terra Linear 1ft (305mm)

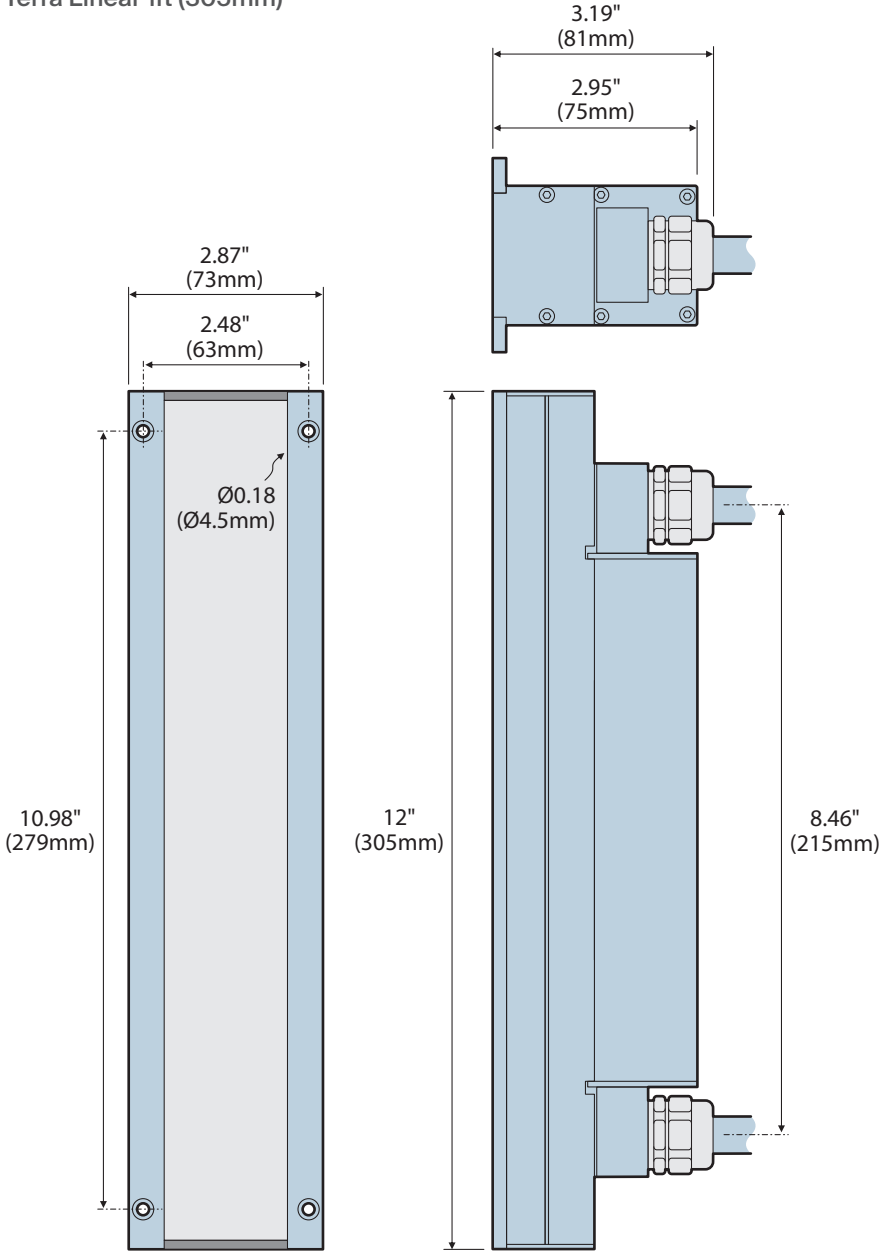

Terra Linear 4ft (1220mm)

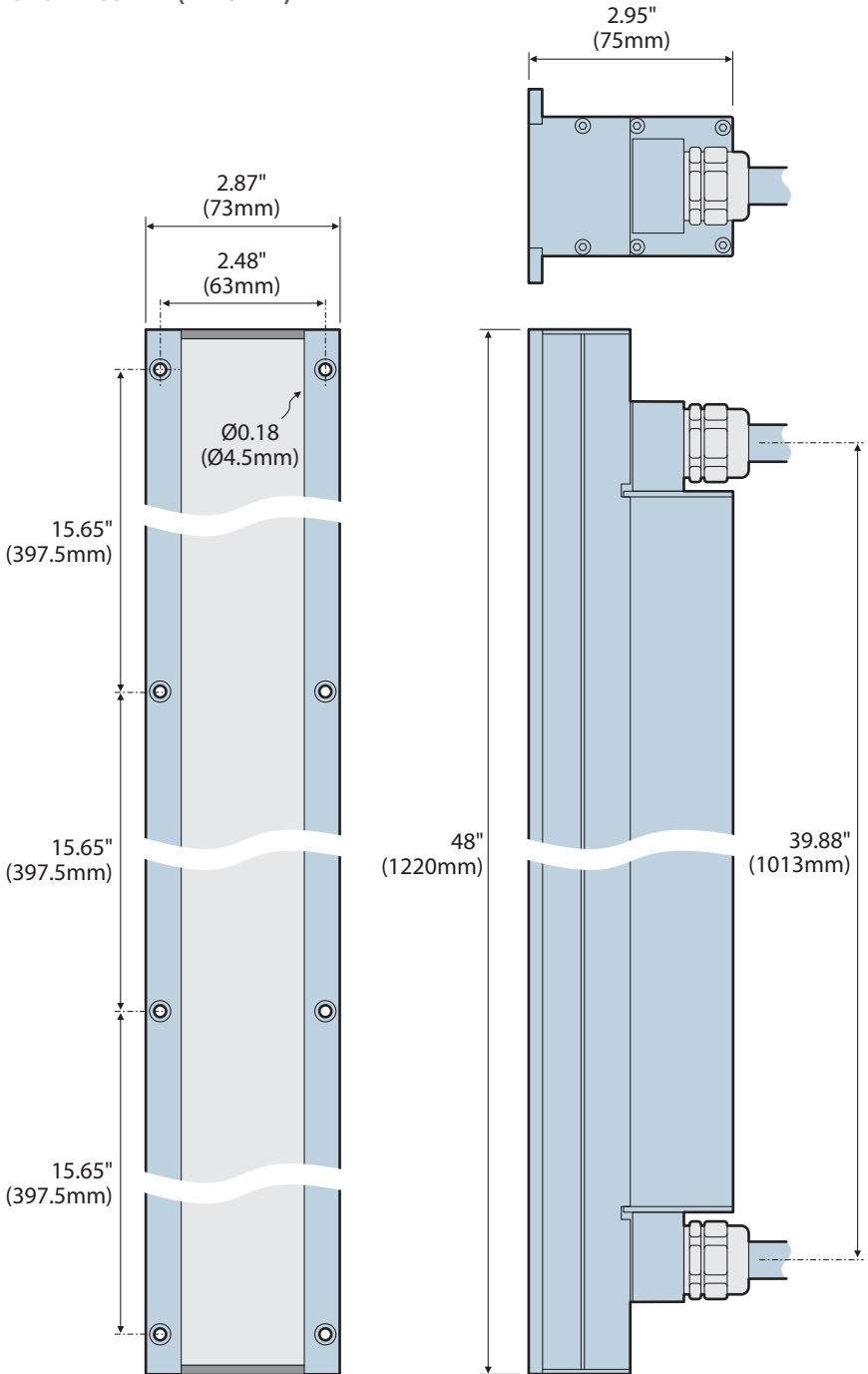

Cables

Feed cable (10 or 50')

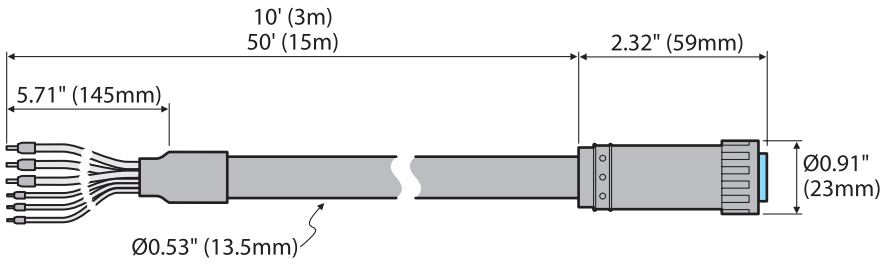

Link cable (1, 5 or 10')

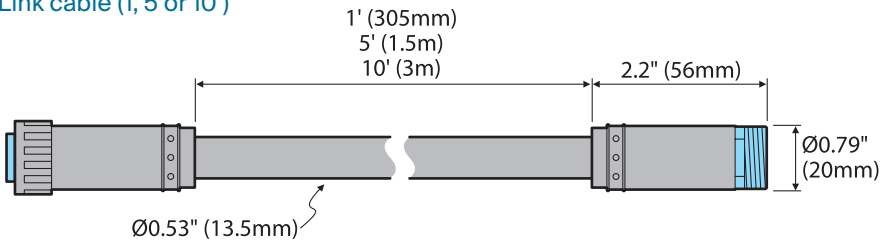

XTR Driver adapter cable

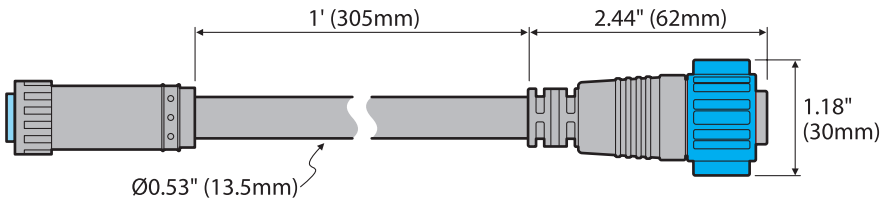

Terminator (end cap)

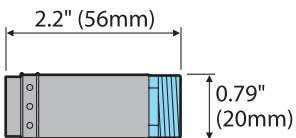

AJBOX1

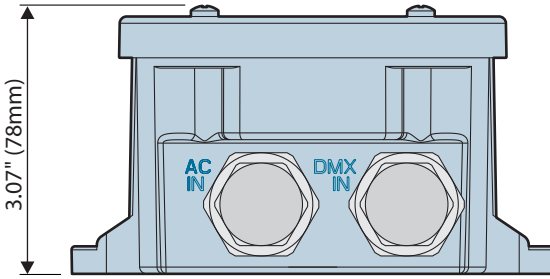
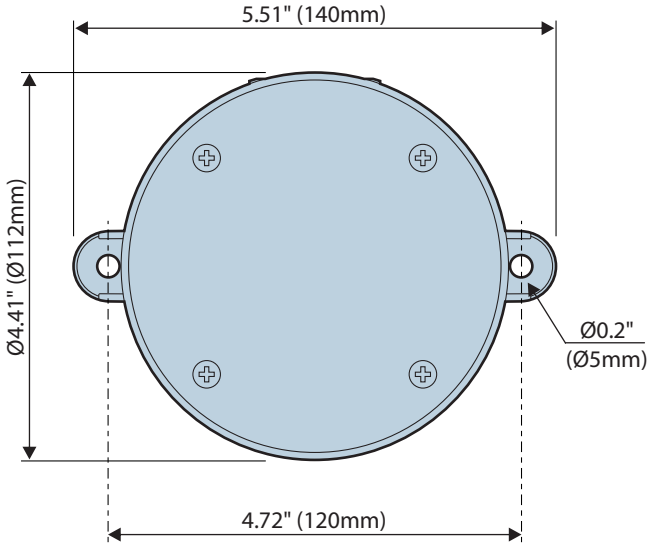

AJBOX1 Extended

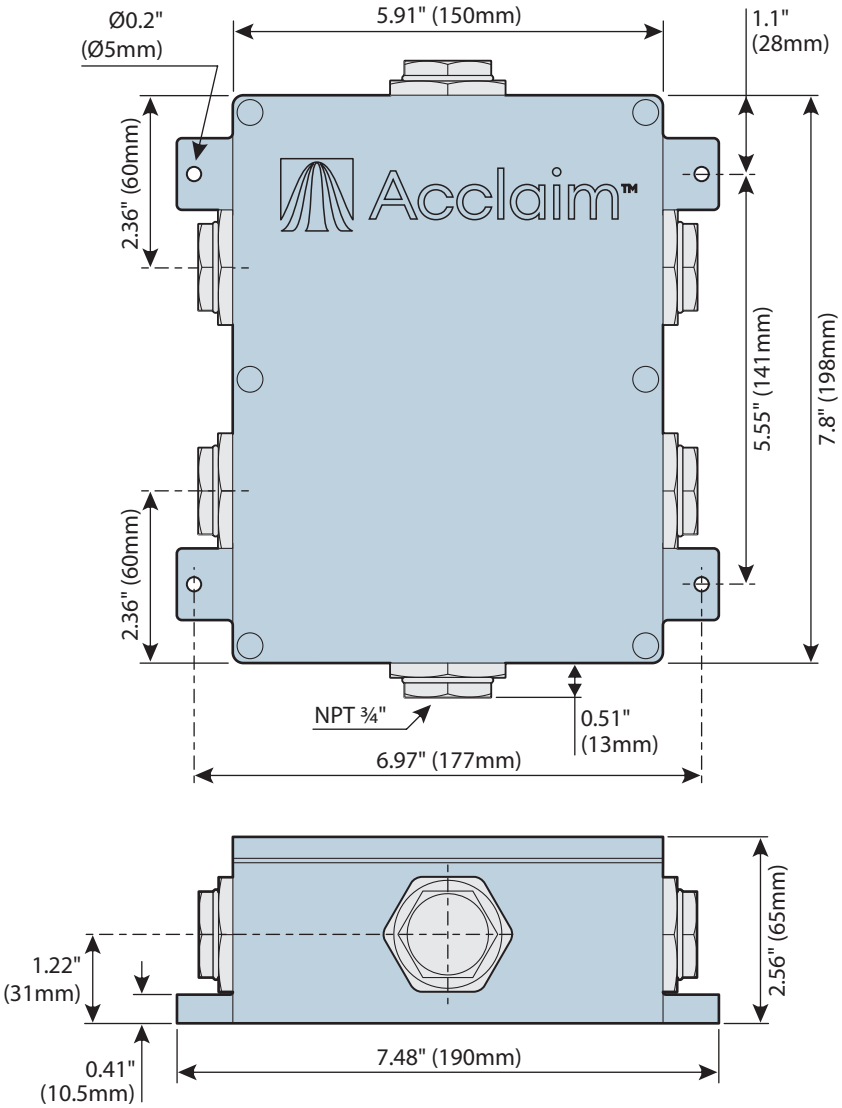

Limited product warranty

A. Acclaim Lighting™ hereby warrants, to the original purchaser, Acclaim Lighting finished products to be free of manufacturing defects in material and workmanship for a standard period of:

- Fixtures: 5 Years (1,825 days) from the date of purchase.
- Drivers, power supplies and accessories: 5 Years (1,825 days) from the date of purchase.
- Flex Products: 3 Years (1,095 days) from the date of purchase.
- Controllers: 2 Years (730 days) from the date of purchase.

It is the owner's responsibility to establish the date and place of purchase and warranty terms by acceptable evidence, at the time service is sought.

B. For warranty service, send the product only to the Acclaim factory. All shipping charges must be pre-paid. If the requested repairs or service (including parts replacement) are within the terms of this warranty, Acclaim Lighting will pay return shipping charges only to a designated point within the United States. If the entire instrument is sent, it must be shipped in its original package. No accessories should be shipped with the product. If any accessories are shipped with the product, Acclaim Lighting shall have no liability whatsoever for loss of or damage to any such accessories, nor for the safe return thereof. Acclaim reserves the right to replace the item with same or similar product at its discretion.

C. This warranty is void if the serial number has been altered or removed; if the product is modified in any manner which Acclaim concludes, after inspection, affects the reliability of the product; if the product has been repaired or serviced by anyone other than the Acclaim Lighting factory unless prior written authorization was issued to purchaser by Acclaim Lighting; if the product is damaged because not properly maintained as set forth in the instruction manual.

D. This is not a service contract, and this warranty does not include maintenance, cleaning or periodic check-up nor do we guarantee as part of this warranty any lumen performance during period. Parts not covered by this warranty include: fuses, external power supplies, third party items not manufactured by Acclaim lighting. During the period specified above, Acclaim Lighting will replace defective parts at its expense, and will absorb all expenses for warranty service and repair labor by reason of defects in material or workmanship. The sole responsibility of Acclaim Lighting under this warranty shall be limited to the repair of the product, or replacement thereof, including parts, at the sole discretion of Acclaim Lighting. At no time will installation or re-installation or products labor or liability costs will be assumed by Acclaim Lighting. All products covered by this warranty were manufactured after January 1, 2012, and bear identifying serial number marks to that effect.

E. Acclaim Lighting reserves the right to make changes in design and/or improvements upon its products without any obligation to include these changes in any products theretofore manufactured. No warranty, whether expressed or implied, is given or made with respect to any accessory supplied with products describe above. Except to the extent prohibited by applicable law, all implied warranties made by Acclaim Lighting in connection with this product, including warranties of merchantability or fitness, are limited in duration to the warranty period set forth above. And no warranties, whether expressed or implied, including warranties of merchantability or fitness, shall apply to this product after said period has expired.

F. Marine or extreme weather location applications using Acclaim lighting products are subject to a 2 year limited warranty and Acclaim must be notified prior to delivery of units for such applications so that preventative treatment can be made to the products to ensure proper performance and product life with a special marine code coating / sealing process at an additional cost.

G. The consumer's and or dealer's sole remedy shall be such repair or replacement as is expressly provide above; and under no circumstances shall Acclaim Lighting be liable for any loss or damage, direct or consequential, arising out of the use of, or inability to use, this product. This warranty is the only written warranty applicable to Acclaim Lighting products and supersedes all prior warranties and written descriptions of warranty terms and conditions heretofore published.



TM