

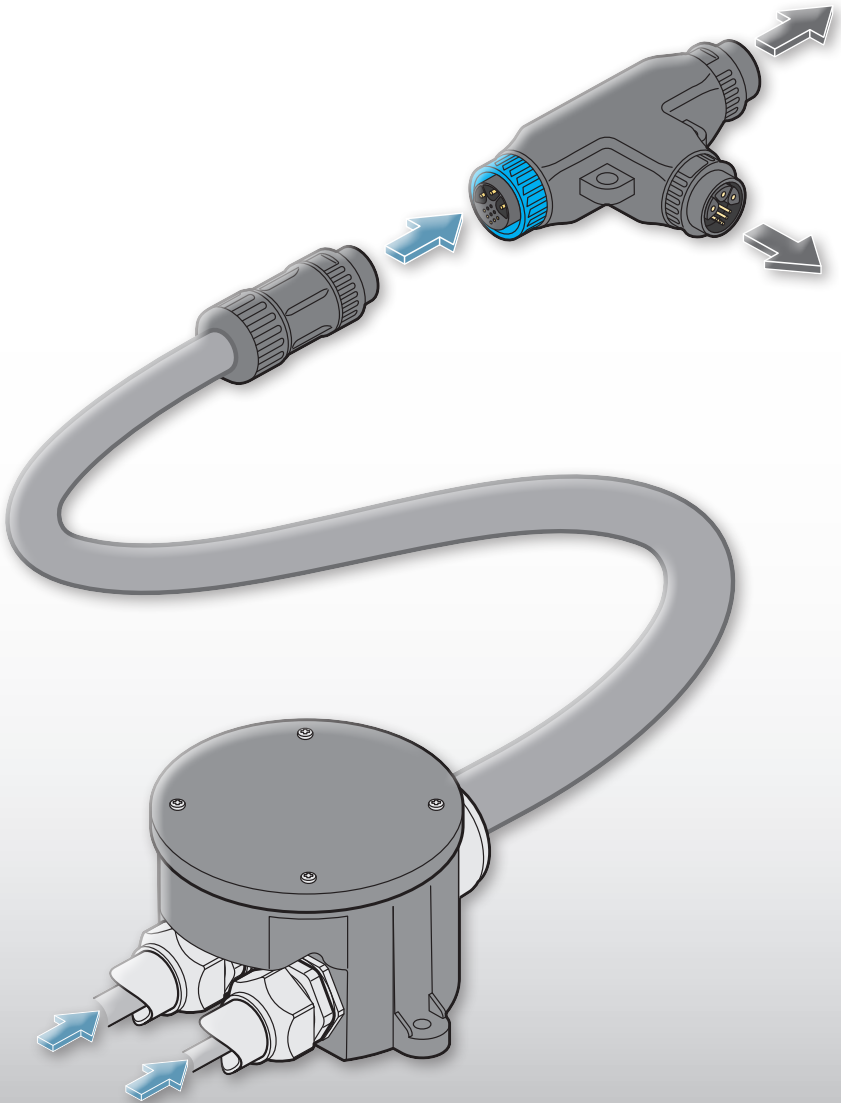

Acclaim™



Outdoor Link System™  
GEN 2

User guide



# Contents

<b>Introduction.....</b>	<b>2</b>
Welcome	2
Safety, maintenance and cleaning	2
Part codes	3
<b>Installation.....</b>	<b>4</b>
Typical OLS configuration	4
Installation limits	5
Important notes	6
OLS connectors	7
Fixtures on a single OLS run	7
OLS junctions	8
The AJBOX1	9
Cable prep	10
Connecting the AJBOX1	11
Additional environmental protection	18
<b>Further information.....</b>	<b>19</b>
Dimensions	20
Limited product warranty	23

# Introduction

## Welcome

The Acclaim Lighting **Outdoor Link System™** is a smart solution to the time-consuming challenge of distributing power and control to multiple exterior lighting fixtures. Utilizing fast-fit IP67-rated hybrid connectors and compact junctions, you can rapidly customize your supply to suit any fixture layout.



Dyna Drum and Dyna Accent fixtures can be fitted with an OLS connector as an option, while Unity fixtures directly accept OLS link cables as standard.

OLS cables and connectors are fully UV-stabilized and flame resistant to UL standards UL 94 V-0 and UL 1581 VW-1. The DMX signal cores are internally shielded within their own sub-cable and the power cores are fully rated to 15A.

OLS comprises various key components, all IP-rated to provide robust operation in all conditions:

- Feed cables - 1' to 50' lengths (30cm to 15.2m)
- Link cables - 1' to 50' lengths (30cm to 15.2m)
- T-junctions and Y-junctions
- End caps with DMX termination

The external power and DMX control inputs are first fed into an AJBOX1 where they are combined into an OLS feed cable. The combined feed cable from the AJBOX1 then connects to the first junction:

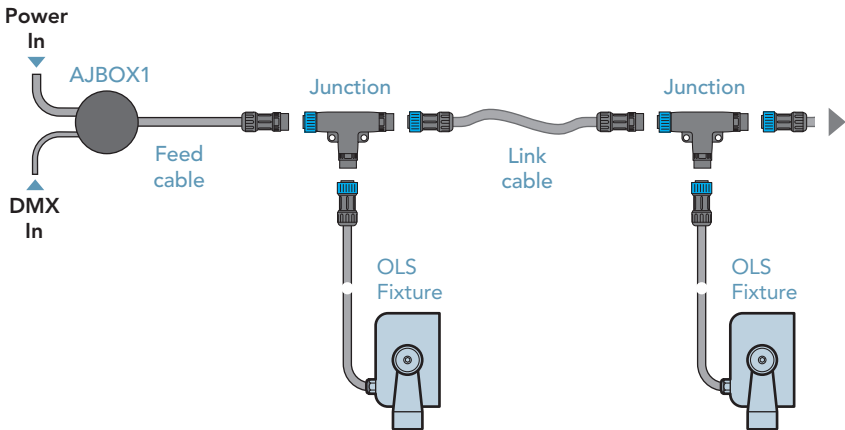

At the first junction, one output supplies power and control to the first fixture while the other continues to the next junction (either directly or via a link cable), where the process is repeated. At the end of the run, an end cap is fitted to simultaneously protect the live connections and correctly terminate the DMX control feed.

The input to each stage is signified by a connector with a blue collar, while all outputs have connectors with black collars (white option available).

## Part codes

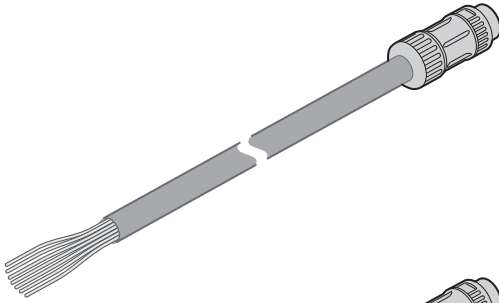

### Feed cables

1' (30cm)	OLSF1#-V2
5' (1.5m)	OLSF5#-V2
10' (3m)	OLSF10#-V2
25' (7.6m)	OLSF25#-V2
50' (15.2m)	OLSF50#-V2

# = color: G-Gray, B-Black, W-White, C-Custom (RAL# required)

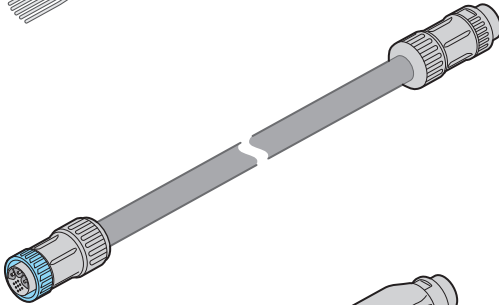

### Link cables

1' (30cm)	OLSL1#-V2
5' (1.5m)	OLSL5#-V2
10' (3m)	OLSL10#-V2
25' (7.6m)	OLSL25#-V2
50' (15.2m)	OLSL50#-V2

# = color: G-Gray, B-Black, W-White, C-Custom (RAL# required)

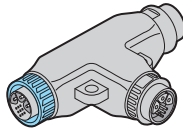

### T-junction

OLST2-B	Black
OLST2-W	White

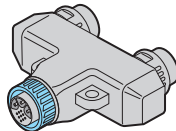

### Y-junction

OLSY2-B	Black
OLSY2-W	White

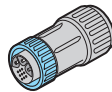

### End cap with DMX termination

OLSEC-B	Black
OLSEC-W	White

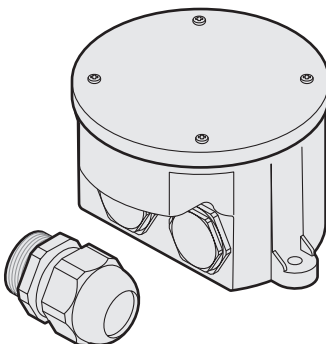

### IP66 junction box plus outlet cable gland

AJBOX1

# Installation

## Typical OLS configuration

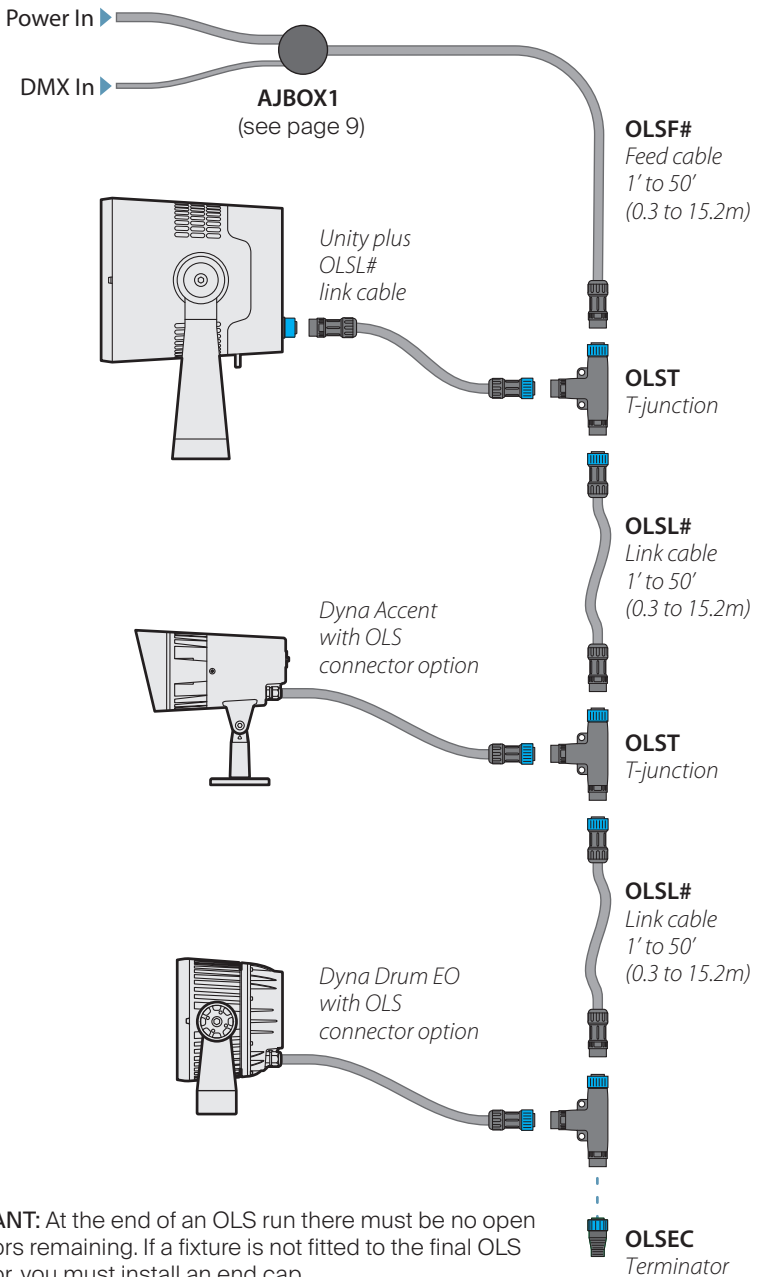

**IMPORTANT:** At the end of an OLS run there must be no open connectors remaining. If a fixture is not fitted to the final OLS connector, you must install an end cap.

**Note:** If a link cable is used between any junction and a fixture input, the link cable must not exceed 10' (3m) in length.

## Installation limits

The power cores within the OLS components impose certain restrictions upon the maximum total cable length and total power draw achievable within an installation.

### Length

There is a need to keep the voltage drop across the whole installation to a maximum of 10% of the supply. This results in the following maximum total cable lengths:

<b>Supply voltage</b>	<i>120VAC</i>	<i>230VAC</i>	<i>277VAC</i>
<b>Maximum length</b>	150 feet (45m)	300 feet (91m)	350 feet (106m)

### Power

A maximum of **15A** can be carried by the cables; this equates to the following maximum total power draws at the various supported supply voltages (see also page 7):

<b>Supply voltage</b>	<i>120VAC</i>	<i>230VAC</i>	<i>277VAC</i>
<b>Maximum power</b>	1,800W	3,450W	4,155W

### In-rush current

Although LED fixtures are low power devices compared to their incandescent equivalents, their power supplies exhibit a trait known as 'in-rush current' when they are first powered on. This is caused by the various components within their switching power supplies topping themselves up with power. When many fixtures are linked to the same power input, they will momentarily yet simultaneously pull a current which can greatly exceed their normal operating level. This may affect over-current trips when power is applied. To reduce the chance of in-rush current causing a trip, we recommend you ensure the supply circuit breaker features a short time-delay curve; most modern circuit breakers include this as standard.

## Important notes

Please note the following points when planning and implementing an installation:

- OLS connectors are not rated for live connection and disconnection. Always ensure that power is isolated before making or breaking any links.
- Ensure the cable is never bent at a radius less than 4" (101mm).
- The DMX header cable connected to the feed cable should be suited for RS-485 data transmission and have a characteristic impedance of 120 Ohms, such as Belden 9842 or equivalent.
- We recommend taking proper precautions for external surge protection, as control and power electronics can be damaged by major events.
- Ensure that:
  - the mains input is derived from a suitable overload-protected supply (see page 5),
  - all cable access points, plus the enclosure cover are correctly sealed,
  - all local codes are followed during planning and installation,
  - connections are made, inspected and certified by a qualified electrician.
- At the end of an OLS run there must be no open connectors remaining. If a fixture is not fitted to the final OLS connector, you must install an end cap (see below also).
- OLS Gen 2 connectors are fully compatible with OLS Gen 1.
- Regardless of which junction type is used, ensure that only one of the outputs continues to form the main run to subsequent fixtures. The minor leg should run only to one fixture and its link cable must not exceed 10' (3m) in length:
- At the end of a run you can either terminate it using an end cap; or attach a single fixture to the final link cable; or use either type of junction and attach a fixture to each of its outputs:

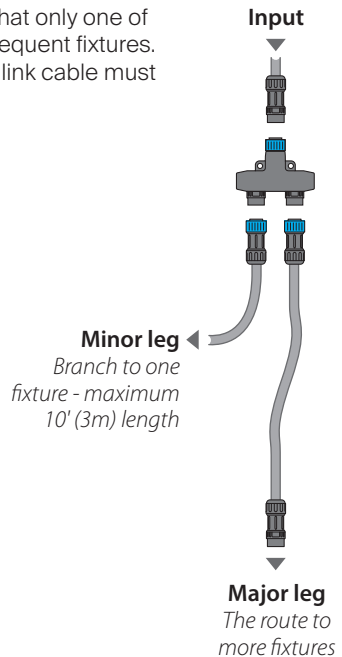
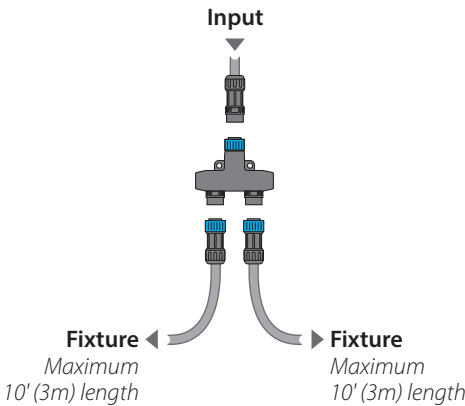
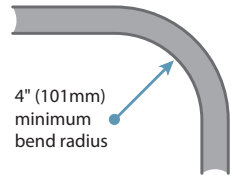

## OLS connectors

The Outdoor Link System uses matching IP67-rated connectors throughout, each of which combines AC power and DMX control. A simple color code is used:

- Connectors with blue collars are inputs,
- Connectors with black collars (white option available) are outputs.

The blue collars form the locking and release mechanism:

### To make a link

Simply align a black and a blue connector and push them together with a click.

### To break a link

Twist and hold the blue collar counter-clockwise and withdraw the black connector.

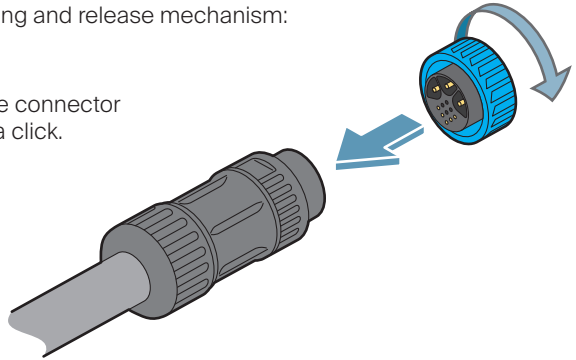

## Fixtures on a single OLS run

The safe current carrying capacity of the OLS cables and connectors is **15A**. The total number of fixtures that can be supported on a single run is determined by the power requirements of the fixtures and also the supply voltage; while the upper limit of 32 fixtures is imposed by the DMX specification.

Fixture type		Max power	# of fixtures @ 120VAC	# of fixtures @ 230VAC	# of fixtures @ 277VAC
<b>Dyna Accent</b>	Mini	13W	32	32	32
	White	40W	32	32	32
	Color	41W	32	32	32
<b>Dyna Drum EO</b>	White	62W	29	32	32
	SCS	55W	32	32	32
	Quad	72W	25	32	32
<b>Dyna Drum SO</b>	White	135W	13	25	30
	SCS	150W	12	23	27
	Quad	150W	12	23	27
<b>Dyna Drum HO</b>	White	200W	9	17	20
	SCS	230W	7	15	18
	Quad	250W	7	13	16
<b>Unity</b>	S1	160W	11	21	25
	H1	330W	5	10	12

## OLS junctions

Two types of OLS junctions are available: T-junctions and Y-junctions. Electrically they are identical, they both split one input into two power/control outputs.

### T-junction

Most useful when the next fixtures are located in different directions from the junction.

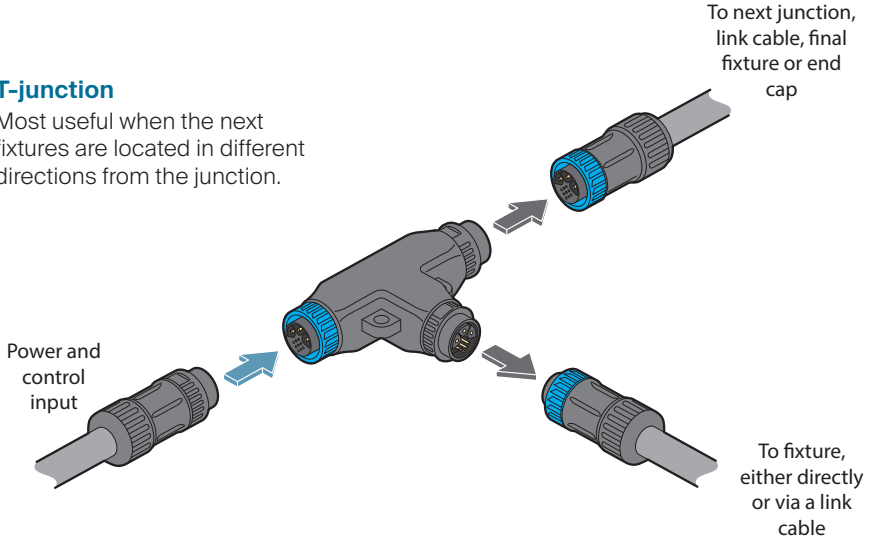

### Y-junction

Most useful when the next fixtures are located in the same direction from the junction.

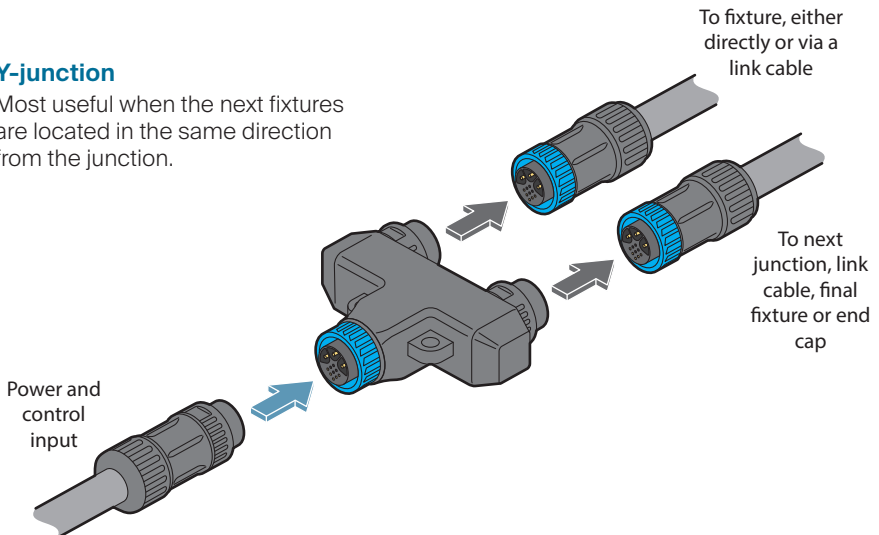

## The AJBOX1

The Acclaim Lighting AJBOX1 is an IP66-rated junction box which is optimized for use with the other OLS components. The AJBOX1 provides separated AC power and DMX control inputs for connection to the combined feed cable:

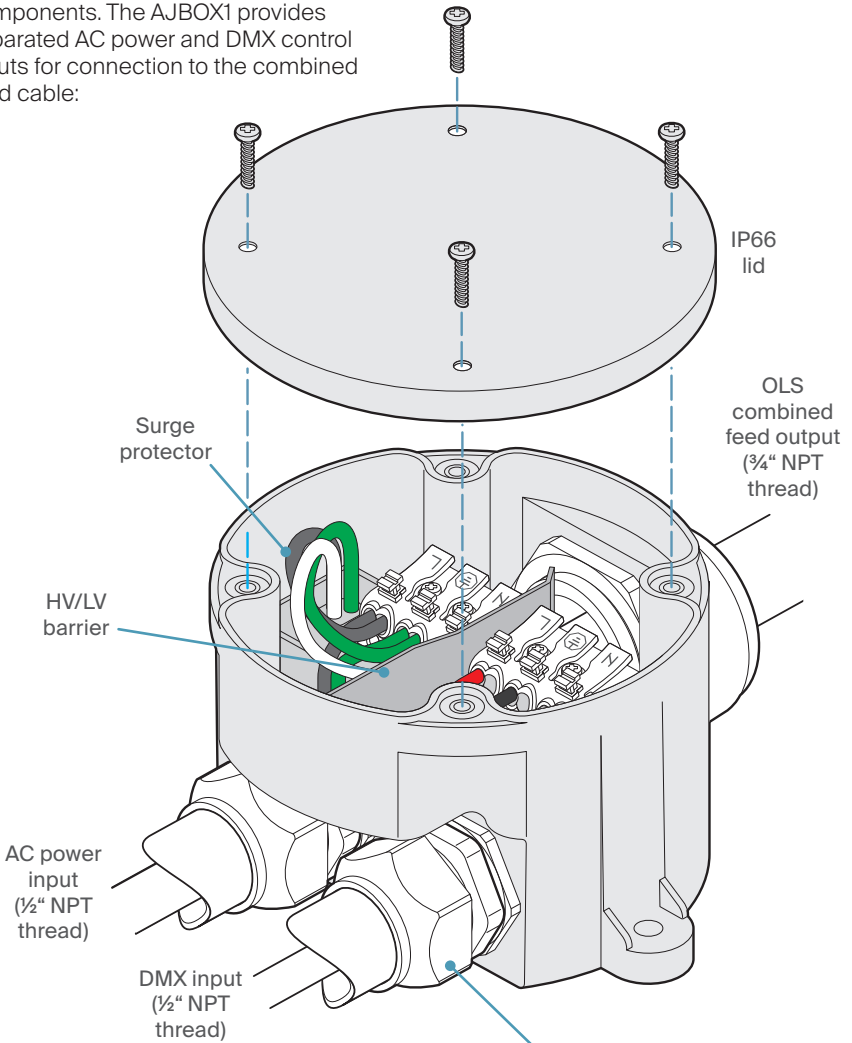

### Input fixtures/glands

You will need to source 3rd-party conduit fixtures/cable glands for the inputs, as suits your installation. The large cable gland for the output is provided with the AJBOX1.

Shown here with cable gland inputs rather than conduit fixtures

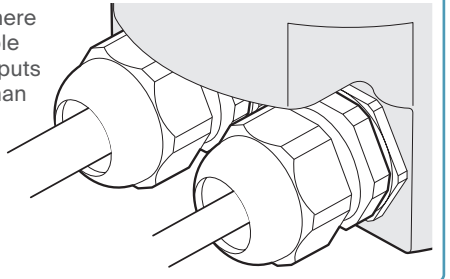

## Cable prep

The AJBOX1 is quite compact considering the number of connections required within it. For best results we recommend that you prepare all cables in the manner shown here in order to provide just enough flexibility without filling the box with excess cable.

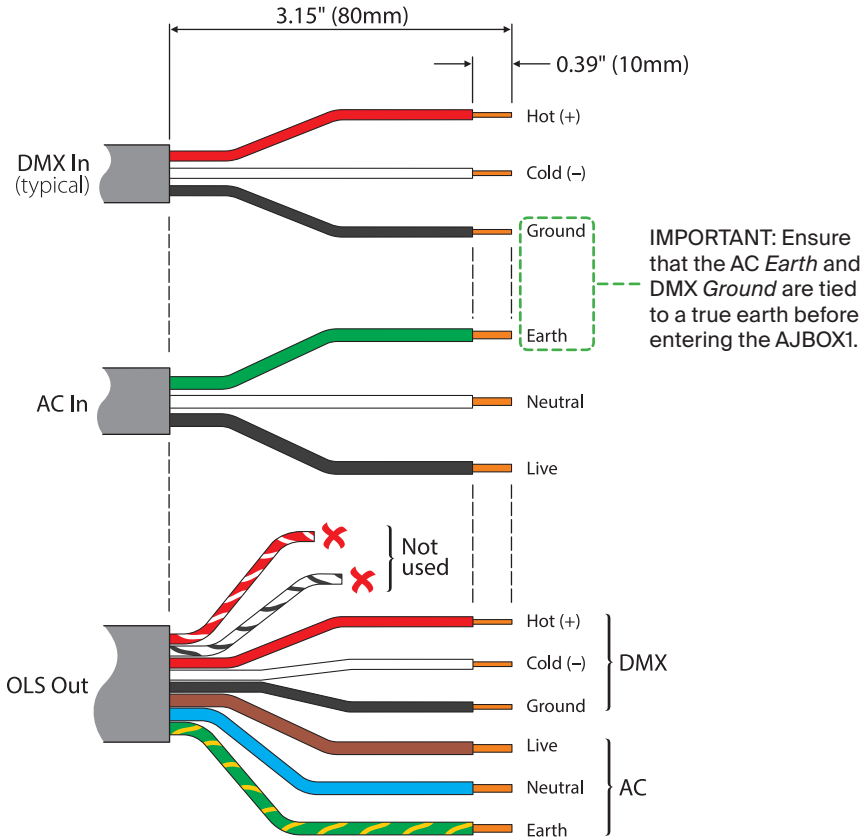

The DMX hot and cold out connections (red/white and white/black striped) are not used and can be trimmed. We suggest that you cut them short at slightly different lengths and ensure that no conductors are visible. Optionally you could also cap them off. Double check that they cannot short together and are well away from the mains connections.

## Cable trim ruler

When this document is printed at 100%, the gauge below is accurate to scale.

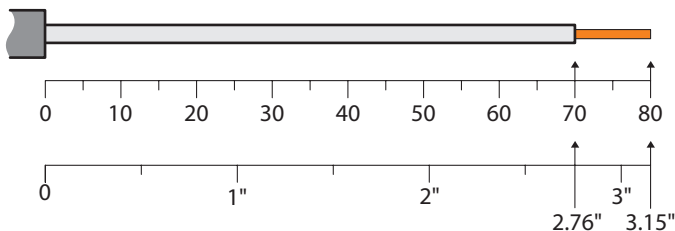

## Connecting the AJBOX1

1 Begin by removing the lid and also the blanking plugs on the main inlet/outlet holes.

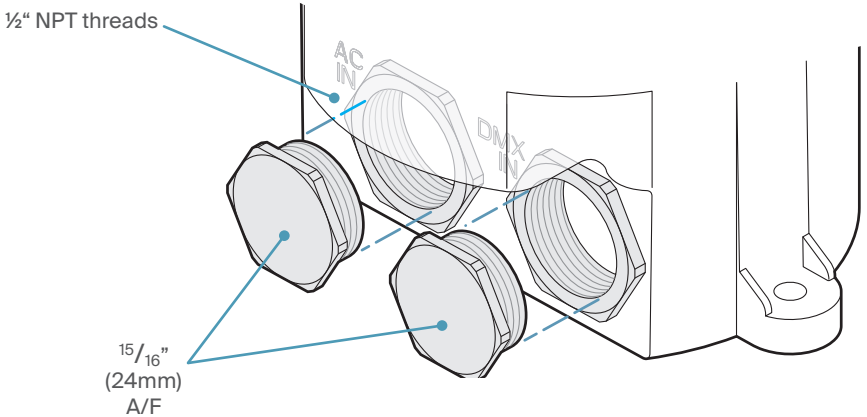
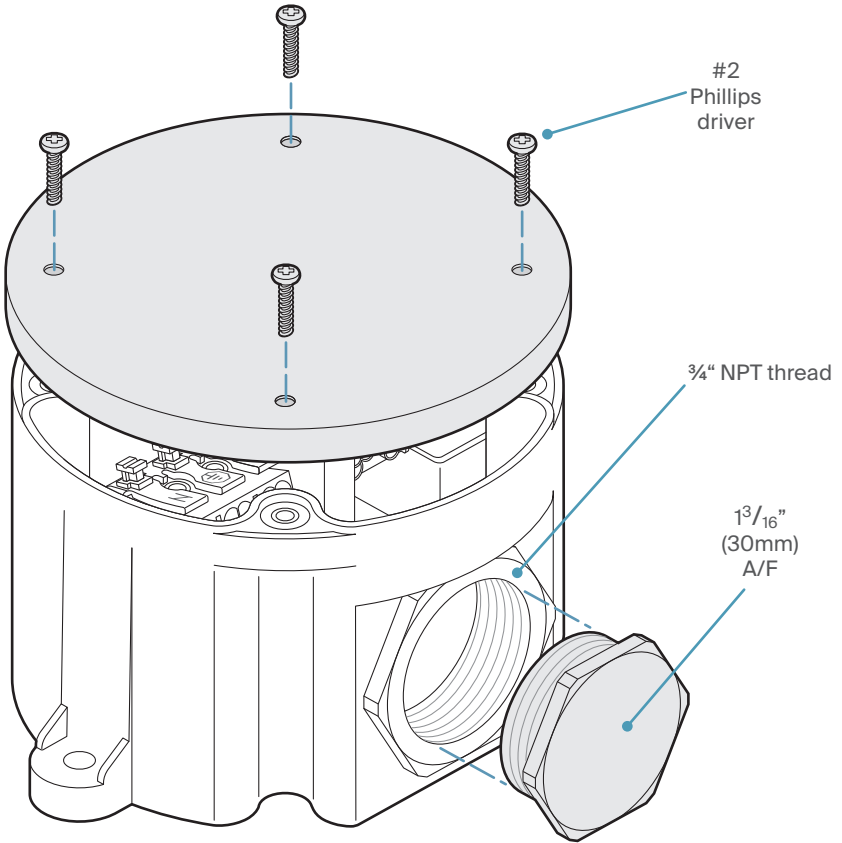

2 If required, gently prise off the rubber seals from the blanking plugs using a small flat blade screwdriver in order to install them on the cable glands/conduit fittings that you're using:

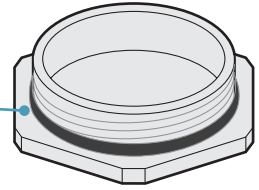

3 If required, place the rubber seals removed above onto your cable glands/conduit fittings.

4 Space is quite tight within the box so it is advisable to release the two connector blocks in order to make them more accessible. Use the #2 Phillips driver to loosen the four screws holding down the connector blocks (there is no need to remove the screws completely).

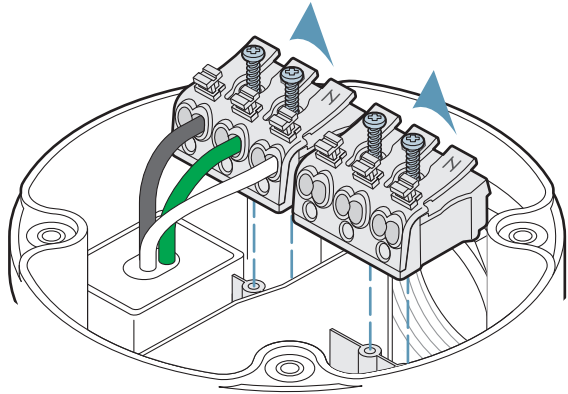

5 **Ensure that the incoming AC power is fully isolated.**

Prep the AC input cable (as shown on page 10), then insert it through your cable gland/conduit fitting and into the marked **AC IN** hole. As space is tight within the box, we recommend that you do not screw the gland/fitting into the box at this stage so that the cable can be more easily manipulated.

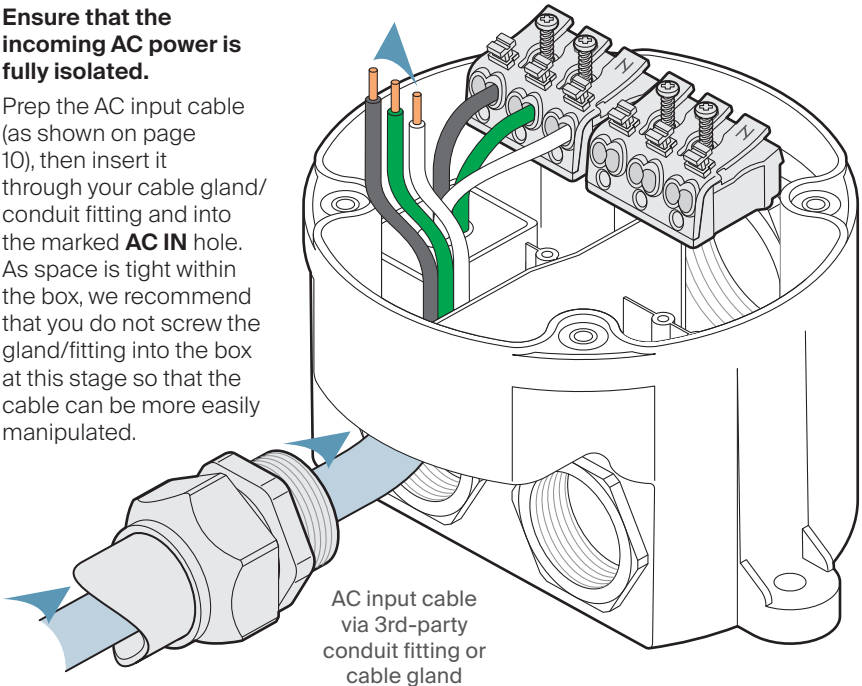

6 In turn, insert the incoming live, earth and neutral lines into the AC IN connector block, alongside and matching the connections from the internal surge protector.

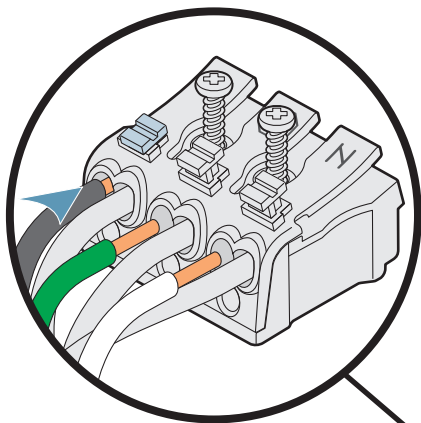

For each input:

- a Press down on the small button (to open the internal spring contacts).
- b Carefully push the correct wire into the vacant hole until the bare conductor goes all the way in.
- c Release the small button and check, by gently pulling the wire, that it is correctly seated and retained.

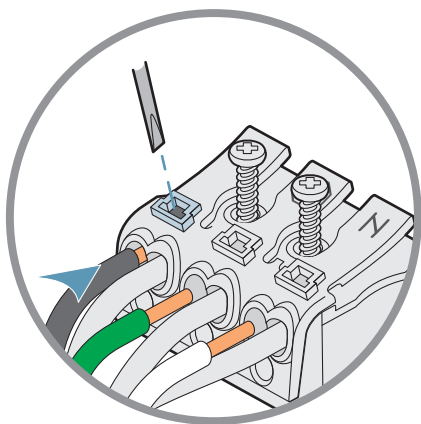
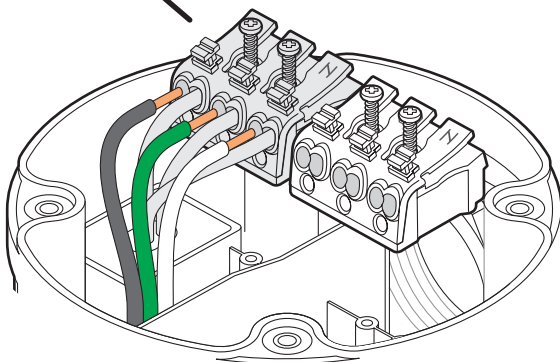

*Note: If the small buttons are not fitted to the connector block, insert a small flatblade screwdriver into each hole to open the spring contacts.*

7 Repeat steps 5 and 6 for the DMX input. Once again, we recommend that you do not screw the gland/ fitting into the box at this stage so that the cable can be more easily manipulated.

*Note: Although the three contacts of the DMX connector block are labeled L, ⊕ and N, we recommend that you decide upon, and adhere to a consistent convention for your DMX connections. We suggest:*

- L = DMX Hot (+)
- ⊕ = DMX Ground
- N = DMX Cold (-)

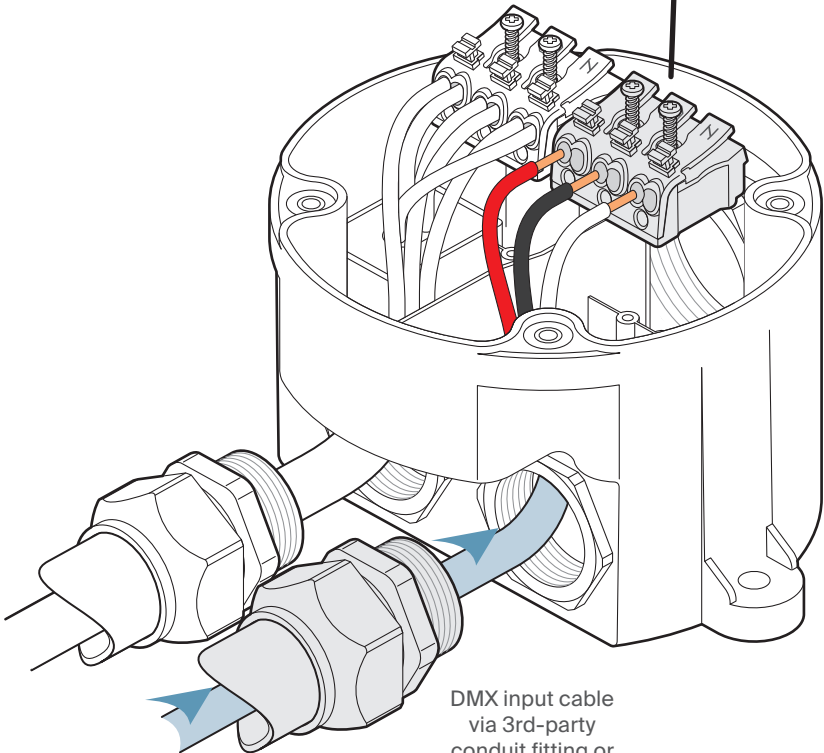
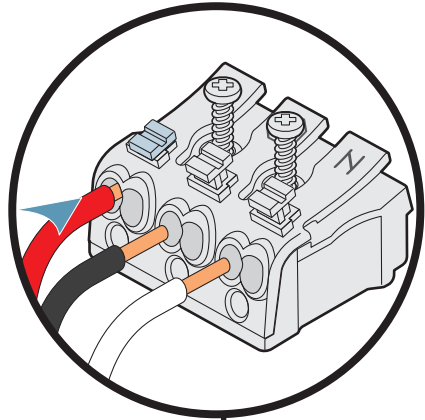

DMX input cable via 3rd-party conduit fitting or cable gland

8 Prep the OLS feed cable (as shown on page 10), then insert it through the large cable gland and into the  $\frac{3}{4}$ " access hole. Once again, we recommend that you do not screw the gland into the box at this stage so that the cable can be more easily manipulated.

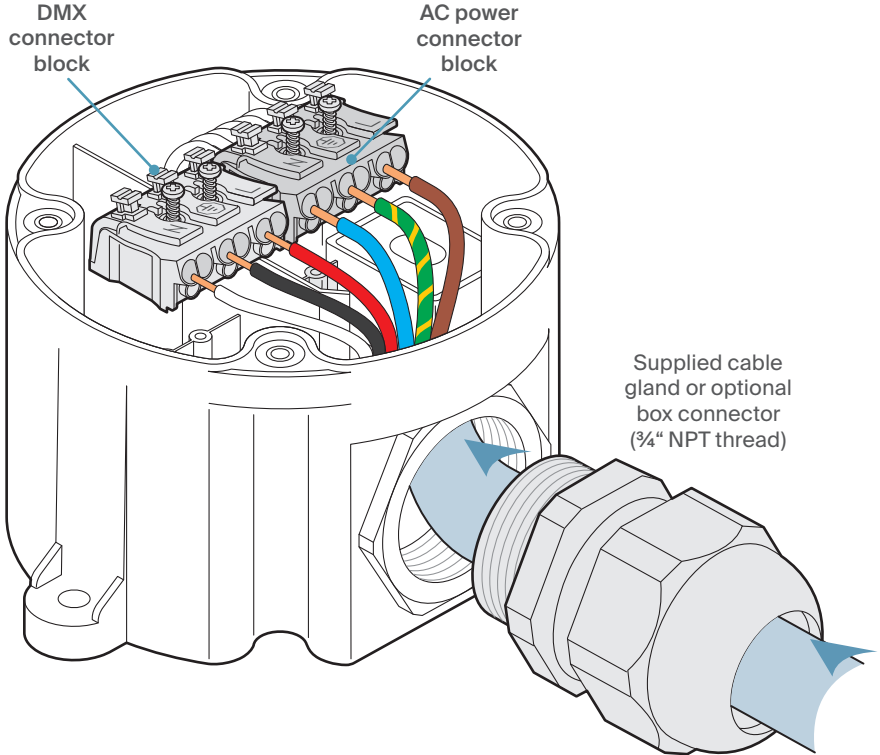

9 In turn, insert the six OLS feed wires into the AC power and DMX connector blocks, taking great care to ensure that the various wires are mated only with the correct terminals (see page 10 for wire designations):

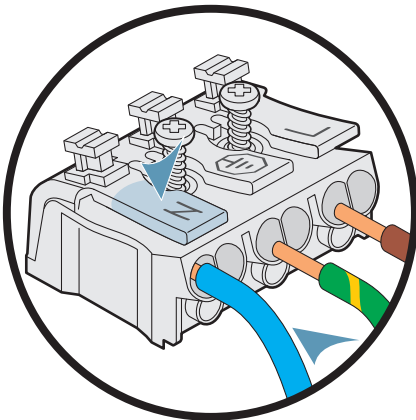

For each input:

- Press down on the lever (to open the internal spring contacts).
- Carefully push the correct wire into either of the adjacent holes until the bare conductor goes all the way in.
- Release the lever and check, by gently pulling the wire, that it is correctly seated and retained.

- 10 Once all connections have been made and double-checked, use a #2 Phillips driver to fix the two connector blocks into place; check for correct alignment with the two screw lugs located on either side of the divider.

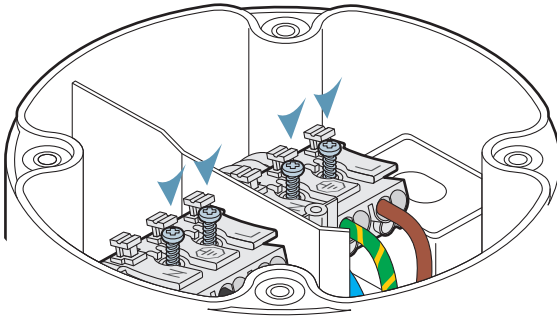

- 11 Apply a bead of suitable silicone sealant to the thread of the large cable gland and run a finger round it to spread the sealant across all parts of the thread.
- 12 Ensure the strain relief cap is loose, then carefully screw the body of the gland into the outlet hole and tighten it using an adjustable wrench.

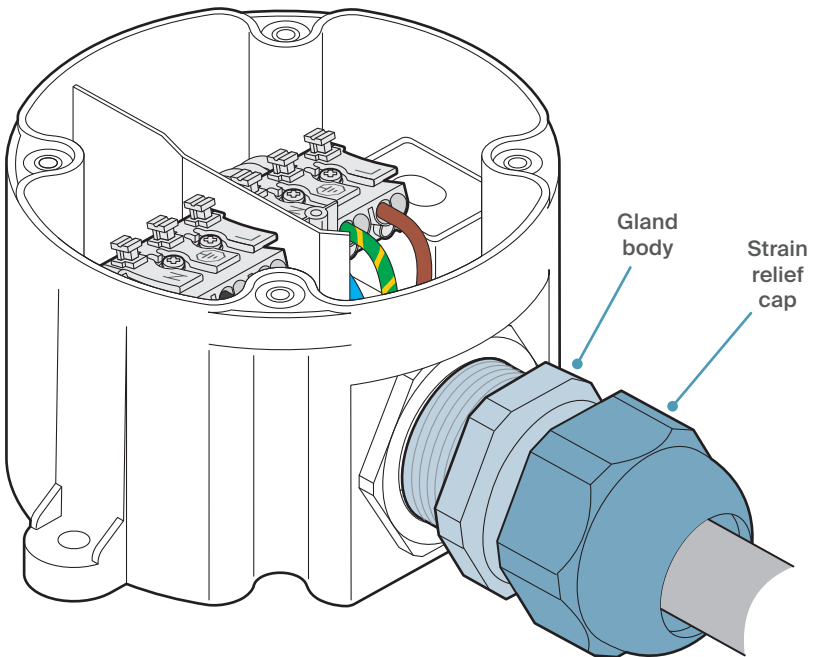

- 13 Push the OLS feed cable slightly into the box (to ensure there's sufficient slack inside) and then tighten the strain relief cap of the gland using an adjustable wrench.

- 14 Apply a bead of suitable silicone sealant to the threads of each conduit fitting/ cable gland and run a finger round them to spread the sealant across all parts of the threads.
- 15 Ensure the strain relief/locking caps are loose, then carefully screw the bodies of each gland into their inlet holes and tighten them using an adjustable wrench.

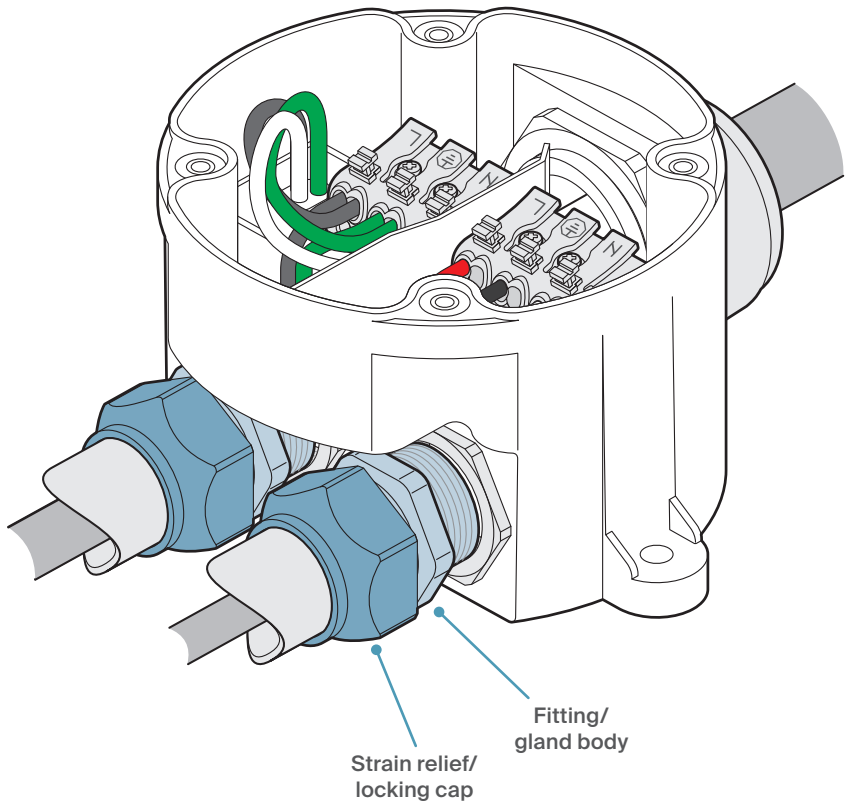

- 16 Push each cable slightly into the box (to ensure there's sufficient slack inside) and then tighten the strain relief/locking caps of the fittings/glands using an adjustable wrench.

17 After a final check, place the lid onto the box, align the holes with the internal threads and insert the four screws.

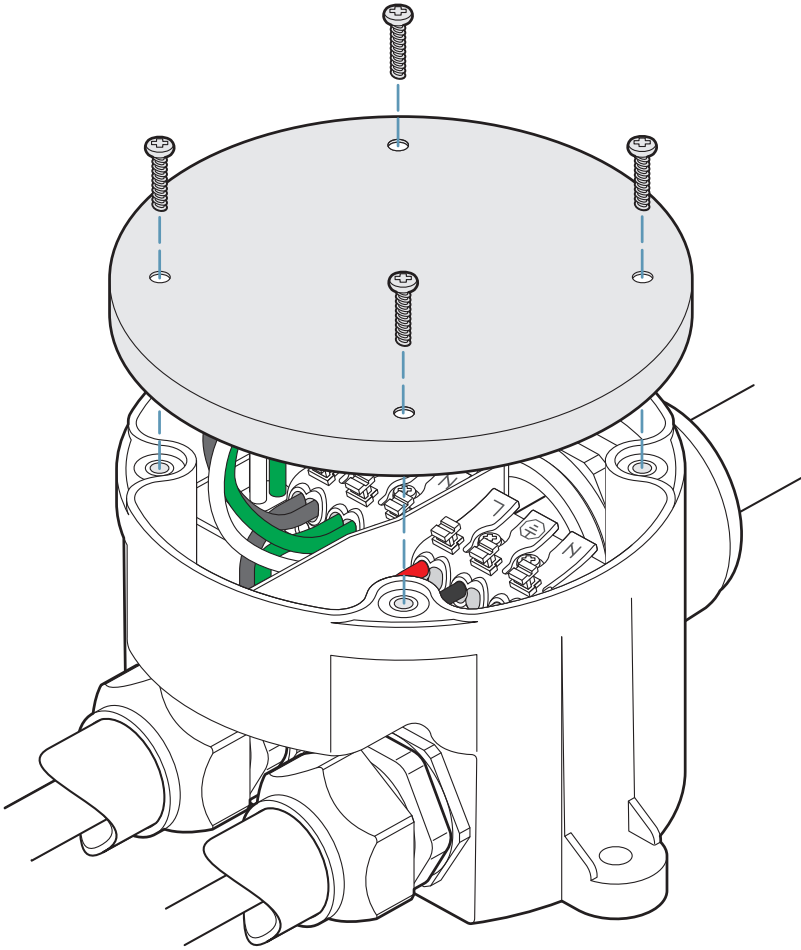

18 Use a #2 Phillips driver to secure the four screws to a reasonable hand-tightness.

### Additional environmental protection

If the AJBOX1 is to be externally wall mounted in a vertical orientation it is advisable to apply extra silicone sealant into and around the strain relief cap of the cable gland/ fitting(s) located on the upper-most surface. This will help to prevent moisture from welling in the head of the gland/fitting and tracking down past the seal into the box.

# Further information

## Cable and connector specifications

Maximum input voltage	305VAC
Maximum total current	15A
Maximum total power	120VAC: 1,800W 230VAC: 3,450W 277VAC: 4,155W
Maximum run length	120VAC: 150' (45m) 230VAC: 300' (91m) 277VAC: 350' (106m)
Surge voltage	1000V
Cable shaping	Minimum bend radius: 4" (101mm)
Cable/connector design	NEC compliant: physical separation of power and low voltage signal conductors
Power conductors	3 x 14AWG
Signal conductors	4 x 20AWG plus shielded ground
Ingress protection	IP67, wet location
Flame resistance	UL 94 V-0 /UL 1581 VW-1
Operating temperature	-40°F to 176°F (-40°C to 80°C)
Connectors	8-pin push-lock with IP67-rated seal
Certifications	



## AJBOX1 specifications

External connection A	Two ½" NPT conduit inlets for separate AC and DMX inputs
External connection B	One ¾" NPT conduit outlet for hybrid OLS feed cable
Internal connections	Two 3-conductor push terminals for AC and DMX links
Maximum conductor size	12 AWG
Maximum input voltage	390VAC
Maximum total current	15A
Maximum total power	120VAC: 1,800W 230VAC: 3,450W 277VAC: 4,155W
Internal design	NEC compliant: physical separation of power and low voltage signal conductors
Internal surge protection	5kA, 10kV
IP rating	IP66, wet location
Ambient temperature range	-40°F to 140°F (-40°C to 60°C)
Certifications	



## Dimensions

### Link cable

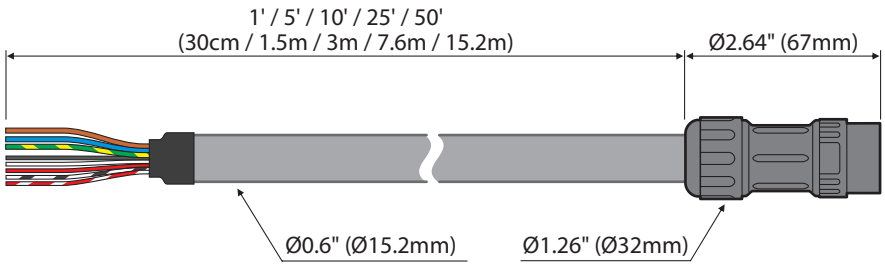

### Link cable

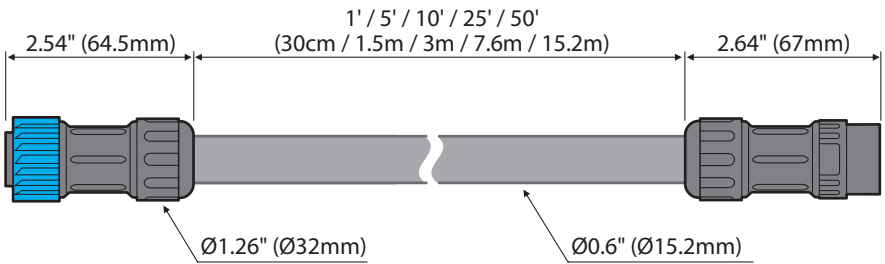

### End cap with DMX termination

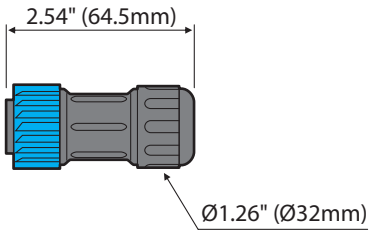

T-Junction

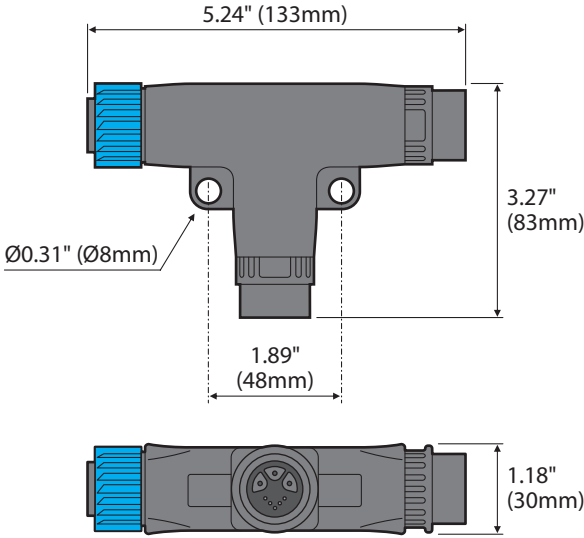

Y-Junction

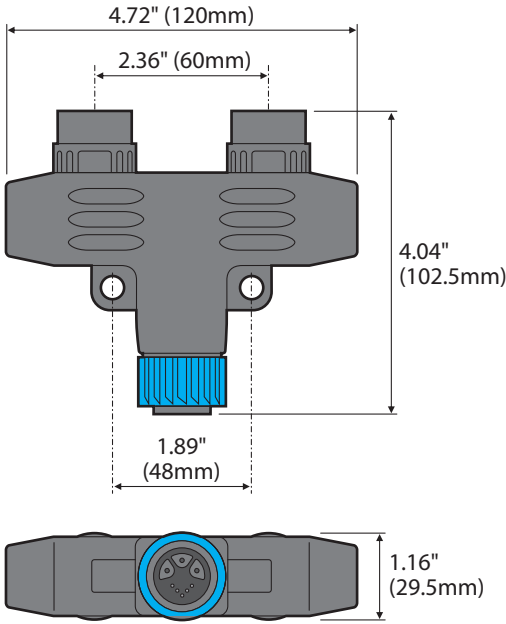

AJBOX1

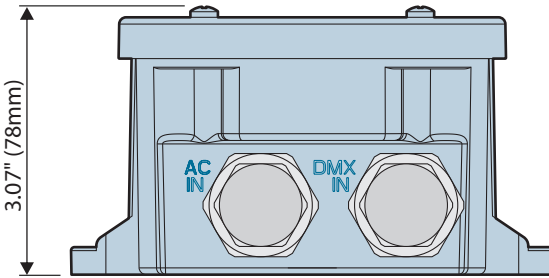
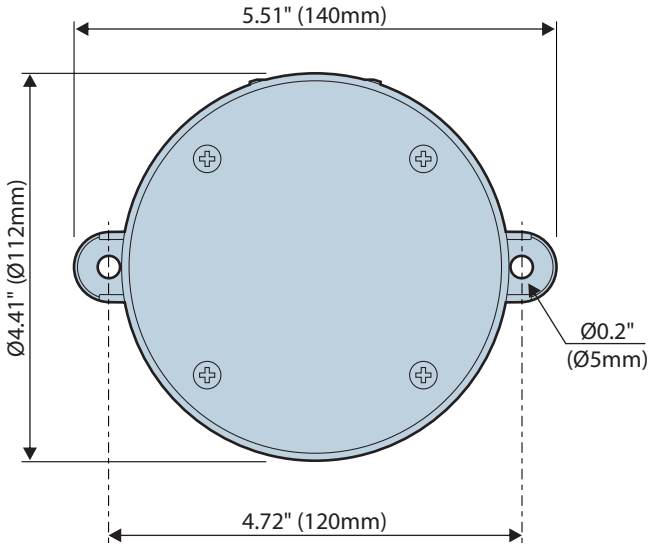

## Limited product warranty

A. Acclaim Lighting™ hereby warrants, to the original purchaser, Acclaim Lighting finished products to be free of manufacturing defects in material and workmanship for a standard period of:

- Fixtures: 5 Years (1,825 days) from the date of purchase.
- Drivers, power supplies and accessories: 5 Years (1,825 days) from the date of purchase.
- Flex Products: 3 Years (1,095 days) from the date of purchase.
- Controllers: 2 Years (730 days) from the date of purchase.

It is the owner's responsibility to establish the date and place of purchase and warranty terms by acceptable evidence, at the time service is sought.

B. For warranty service, send the product only to the Acclaim factory. All shipping charges must be pre-paid. If the requested repairs or service (including parts replacement) are within the terms of this warranty, Acclaim Lighting will pay return shipping charges only to a designated point within the United States. If the entire instrument is sent, it must be shipped in its original package. No accessories should be shipped with the product. If any accessories are shipped with the product, Acclaim Lighting shall have no liability whatsoever for loss of or damage to any such accessories, nor for the safe return thereof. Acclaim reserves the right to replace the item with same or similar product at its discretion.

C. This warranty is void if the serial number has been altered or removed; if the product is modified in any manner which Acclaim concludes, after inspection, affects the reliability of the product; if the product has been repaired or serviced by anyone other than the Acclaim Lighting factory unless prior written authorization was issued to purchaser by Acclaim Lighting; if the product is damaged because not properly maintained as set forth in the instruction manual.

D. This is not a service contract, and this warranty does not include maintenance, cleaning or periodic check-up nor do we guarantee as part of this warranty any lumen performance during period. Parts not covered by this warranty include: fuses, external power supplies, third party items not manufactured by Acclaim lighting. During the period specified above, Acclaim Lighting will replace defective parts at its expense, and will absorb all expenses for warranty service and repair labor by reason of defects in material or workmanship. The sole responsibility of Acclaim Lighting under this warranty shall be limited to the repair of the product, or replacement thereof, including parts, at the sole discretion of Acclaim Lighting. At no time will installation or re-installation or products labor or liability costs will be assumed by Acclaim Lighting. All products covered by this warranty were manufactured after January 1, 2012, and bear identifying serial number marks to that effect.

E. Acclaim Lighting reserves the right to make changes in design and/or improvements upon its products without any obligation to include these changes in any products theretofore manufactured. No warranty, whether expressed or implied, is given or made with respect to any accessory supplied with products describe above. Except to the extent prohibited by applicable law, all implied warranties made by Acclaim Lighting in connection with this product, including warranties of merchantability or fitness, are limited in duration to the warranty period set forth above. And no warranties, whether expressed or implied, including warranties of merchantability or fitness, shall apply to this product after said period has expired.

F. Marine or extreme weather location applications using Acclaim lighting products are subject to a 2 year limited warranty and Acclaim must be notified prior to delivery of units for such applications so that preventative treatment can be made to the products to ensure proper performance and product life with a special marine code coating / sealing process at an additional cost.

G. The consumer's and or dealer's sole remedy shall be such repair or replacement as is expressly provide above; and under no circumstances shall Acclaim Lighting be liable for any loss or damage, direct or consequential, arising out of the use of, or inability to use, this product. This warranty is the only written warranty applicable to Acclaim Lighting products and supersedes all prior warranties and written descriptions of warranty terms and conditions heretofore published.



TM