

150W LED Driver

Outdoor & Indoor Magnetic LED Driver

Product Code: M150L24DC-277

Magnitude's M150L24DC-277 LED Driver is the perfect choice for use in hospitals, schools, and shopping malls or for any commercial application that 277V is present. The Drivers are encased in a high-quality NEMA 3R enclosure that includes 2 knock-outs to enable easy installation. It is equipped with a push to reset breaker on the output for load protection.

Features

- Push-to-reset breaker
- ETL listed
- CSA listed
- Commercial Use
- flicker-free
- Nema 3R enclosure
- Wiring compartment with 2 knock-outs for clean and easy installation.

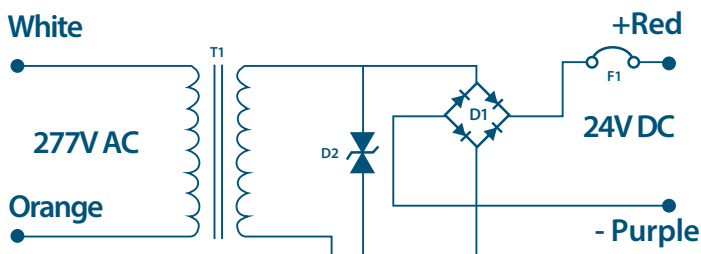
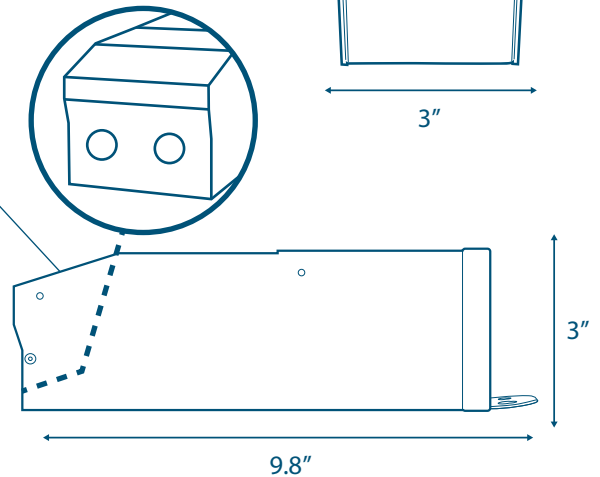
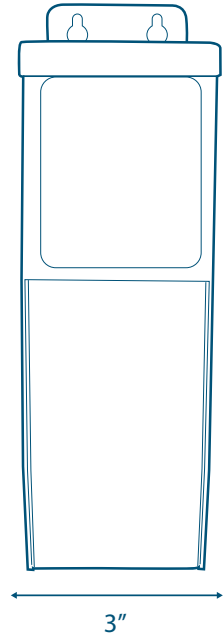

Driver's Specifications

Max Load	150W
Input Voltage	277V AC
Input Current Full Load	1.95 A
Output Voltage Full Load	22.1V DC
Max Output Current Full Load	13.3 A
Open Circuit Output Voltage	24.5V DC
Efficiency on I	80%
Power Factor on I	0.93
Coil Former	Double Section Bobbin
Thermal Class	B130°C
Leads Primary	PVC 600V #18
Leads Secondary	PVC 300V #12
Circuit Breaker	secondary manual push-to-reset
Dimensions L*W*H	9.8 in. x 3 in. x 3 in. (248.9 mm x 76.2 mm x 76.2 mm)
Weight	87 Oz.

The specifications are subject to change without notice