

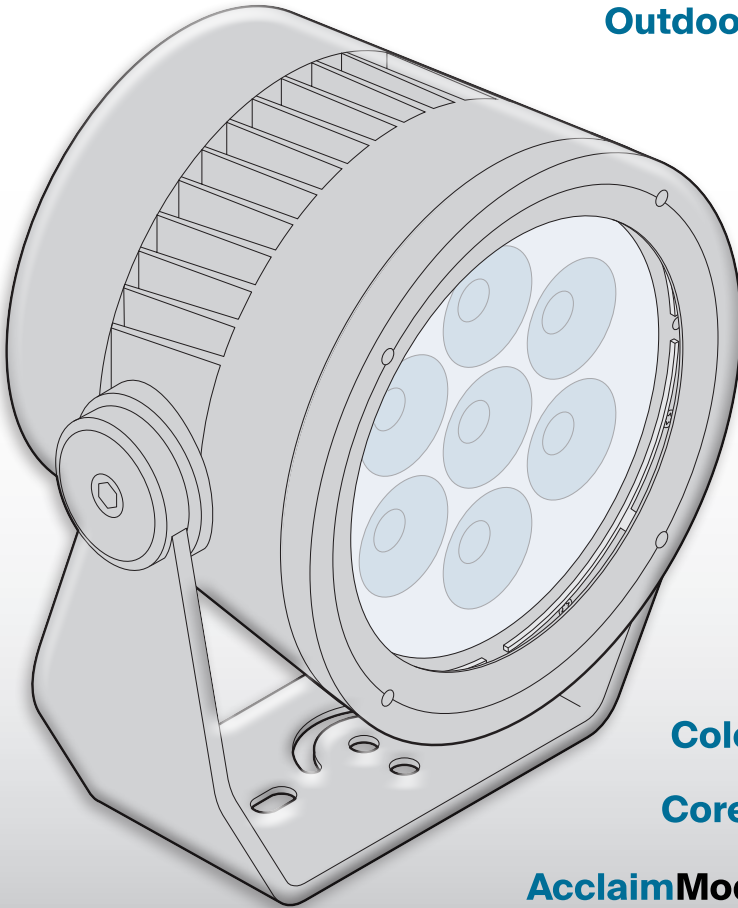

Acclaim™



SpectrumFour
technology

OutdoorLink
system

aria
MULTI-BAND WIRELESS CONTROL

ColorDrive
technology

CoreSwap
technology

AcclaimModular
systems

Dyna Drum S3™

User guide

Contents

Introduction.....	3
Welcome	3
Safety, maintenance and cleaning	3
Supplied items	4
Optional extras	4
Outdoor Linking System items	7
Installation.....	8
Mounting the unit	8
Using a tenon mount	9
Using a pipe clamp	10
Fitting a spread lens	11
Fitting a half or full snoot	12
Fitting a wide snoot	13
Fitting a wire guard	14
Swapping out a module or emitter head	15
Power and control wiring	16
208VAC phase-to-phase operation	16
Wired DMX control	18
Tips for achieving successful DMX control	18
Feed wiring protection: AJBOX1	19
Feed wiring protection: AJBOX1-Extended	20
Cabling with OLS	22
Typical OLS configuration	23
Wireless DMX control	24
Configuration.....	25
Uncovering the display	25
Entering the menu	25
Main menu items	26
Setting the DMX address	27
Color calibration	27
Returning to factory settings	28
Viewing fixture information	28
Selecting the channel mode	29
Channel modes for WHITE emitters	29
Channel modes for COLOR emitters	29
Channel modes for SCS emitters	31
Determining solo behavior	34
Setting an internal color	34
Using the automation features (Photocell)	35
Configuring Aria X2 wireless DMX	36
Adjusting the gamma setting	38

Adjusting the PWM frequency	38
Changing the display settings	39
Running a system test	39
Setting a white balance	40
Configuration via RDM	41
Setting the DMX address via RDM	42
Setting the DMX personality (channel mode) via RDM	43
Configuring Aria X2 wireless via RDM	44
Determining the solo behavior via RDM	45
Setting an internal color via RDM	46
Setting the automation features (photocell) via RDM	47

Further information..... 48

Troubleshooting	48
Correlated color temperature (CCT) selection	49
Optimizing signal strength via channel selection (2.4GHz)	50
Aria X2 Sub-GHz (900MHz) bands	51
Choosing the right location	52
Dyna Drum specifications	53
Outdoor Linking System (OLS) specifications	53
Dimensions	54
Dyna Drum S3	54
AJBOX1	55
AJBOX1 Extended	56
Limited product warranty	57

Introduction

Welcome

The **Dyna Drum™** family of floodlights has been the premier choice of serious designers for years; their high outputs, robust weather protection and unmatched reliability are legendary. The **Dyna Drum S3™** models sit in the middle of the family and produce outsized levels of output to serve professional applications.

Dyna Drum fixtures are equally happy to receive DMX control via cable or the airwaves, thanks to the Aria™ X2 wireless receiver built into every unit. A clear daylight-readable OLED touch-screen display provides access to a comprehensive configuration menu system. Alternatively, key configuration changes can be made remotely using RDM (Remote Device Management) via the DMX wired connection.

Dyna Drum S3 fixtures feature automated operation when light levels fall below a certain level together with a timer for auto shut off. The internal auto-sensing power supply can accept mains inputs between 100 to 277VAC at 50 or 60Hz.

Dyna Drum S3 fixtures use OLS connectors to make them instantly compatible with Acclaim's celebrated Outdoor Link System: the rapid-fit cabling solution your installers will never want to be without.

Safety

- When fixtures are mounted off-ground, ensure they are securely fitted to an appropriate mounting surface.
- Ensure that the power input is supplied from a correctly fused, earthed and environmentally protected location.

Maintenance

CAUTION: Always isolate mains power before starting maintenance operations.

- Ensure that all mounting (and device) screws/bolts are fully tight and free of corrosion.
- Ensure there is no deformation to the housing, lenses or fixing points.
- Check that all power supply cables are free from physical damage or material fatigue.
- Use only genuine spare parts supplied by Acclaim Lighting.

Cleaning

- Use a moist, lint-free cloth when cleaning each fixture.
- Never use alcohol or solvents.

Supplied items

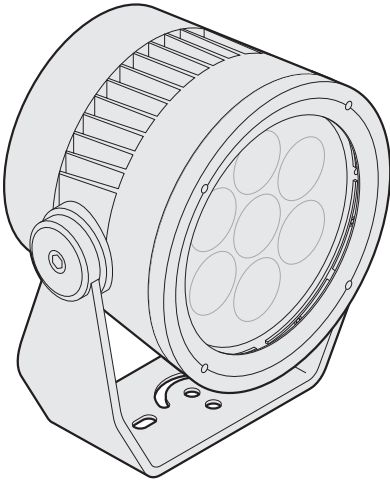

Dyna Drum S3

Supplied with integral mounting yoke and detachable 9 foot (2.7m) combined power and control tail plus female blanking plug. Optional Outdoor Linking System cables and accessories are directly compatible - see page 7.

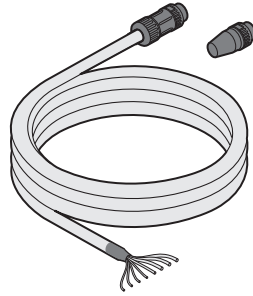

Optional extras

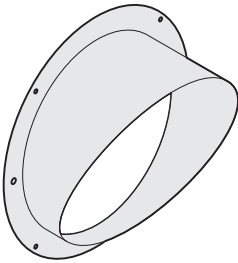

Half snoots

Gray	DS3HSG
Black	DS3HSB
White	DS3HSW
Custom*	DS3HSC

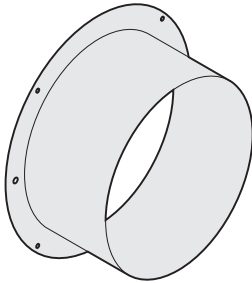

Full snoots

Gray	DS3FSG
Black	DS3FSB
White	DS3FSW
Custom*	DS3FSC

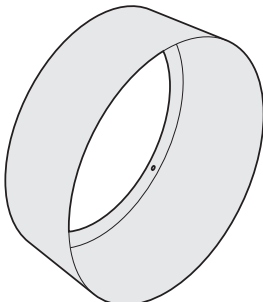

Wide snoots

Gray	DS3WSG
Black	DS3WSB
White	DS3WSW
Custom*	DS3WSC

*RAL # also required

Optional extras

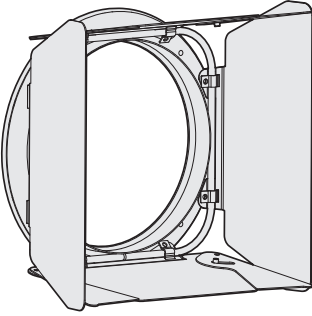

Barn doors

Gray	DS3BDAG
Black	DS3BDAB
White	DS3BDAB
Custom*	DS3BDAC

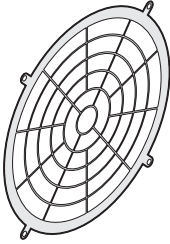

Wire guards

Gray	DS3WGG
Black	DS3WGB
White	DS3WGW
Custom*	DS3WGC

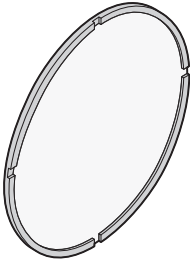

Spread lenses

10° beam	DS3OC
20° beam	DS3OD
40° beam	DS3OH
60° beam	DS3OK
100° beam	DS3OM
30° x 60° beam	DS3OQ
10° x 60° beam	DS3OR

* RAL # also required

Optional extras

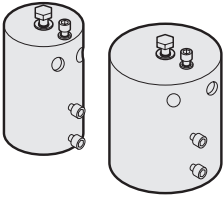

Tenon mounts

2" schedule 40 (2.51", 56mm inner dia.)	TM2 S40
2" nominal (2", 51mm inner dia.)	TM2 NOM
3.5" schedule 40 (4.13", 105mm inner dia.)	TM4 S40
4" nominal (4", 102mm inner dia.)	TM4 NOM

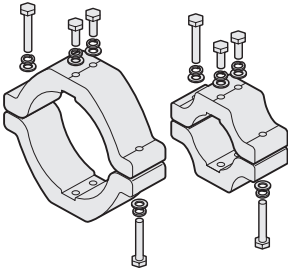

Pipe clamps

2" schedule 40	PC2 S40
2" nominal	PC2 NOM
4" schedule 40	PC4 S40
4" nominal	PC4 NOM

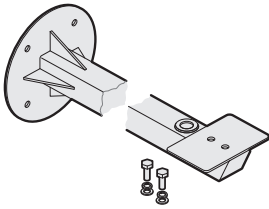

Extender bars

	1'	2'	3'
Gray	OFLEB1G	OFLEB2G	OFLEB3G
Black	OFLEB1B	OFLEB2B	OFLEB3B
White	OFLEB1W	OFLEB2W	OFLEB3W
Custom*	OFLEB1C	OFLEB2C	OFLEB3C

Outdoor Linking System items

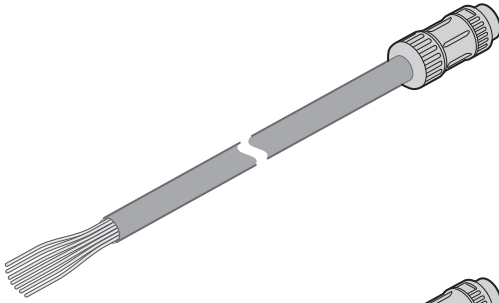

Feed cables

1' (30cm)	OLSF1#-V2
5' (1.5m)	OLSF5#-V2
10' (3m)	OLSF10#-V2
25' (7.6m)	OLSF25#-V2
50' (15.2m)	OLSF50#-V2

= color: G-Gray, B-Black, W-White, C-Custom (RAL# required)

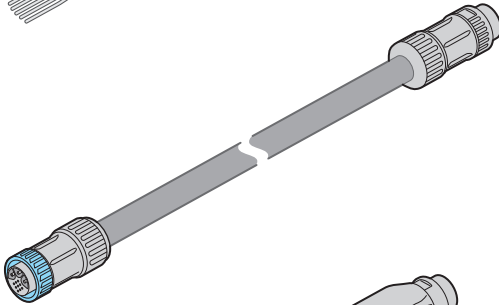

Link cables

1' (30cm)	OLSL1#-V2
5' (1.5m)	OLSL5#-V2
10' (3m)	OLSL10#-V2
25' (7.6m)	OLSL25#-V2
50' (15.2m)	OLSL50#-V2

= color: G-Gray, B-Black, W-White, C-Custom (RAL# required)

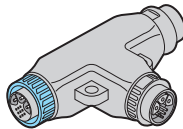

T-junction

OLST2-B	Black
OLST2-W	White

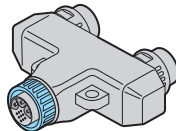

Y-junction

OLSY2-B	Black
OLSY2-W	White

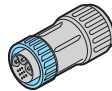

End cap with DMX termination

OLSEC-B	Black
OLSEC-W	White

Round IP66 junction box plus outlet cable gland
AJBOX1

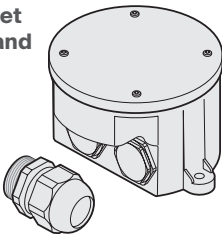

Large IP66 junction box with DMX pass-thru
AJBOX1E

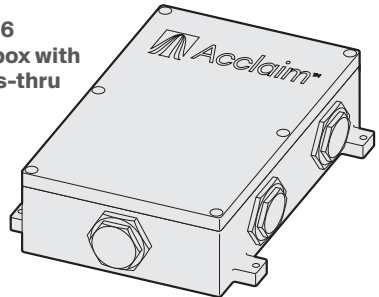

Installation

Mounting the unit

Each Dyna Drum fixture includes a sturdy yoke mount with multiple holes in its base for various fixing options. Dyna Drum S3 fixtures weigh 19 lbs (8.61 kg) - ensure that the mounting surface and the fixings used are sufficiently rated for the task (including wind shear forces).

IMPORTANT: When mounting a Dyna Drum fixture off ground, ensure that a suitably rated safety wire links the anchor hole at the rear of the Dyna Drum with a sturdy secondary fixing point.

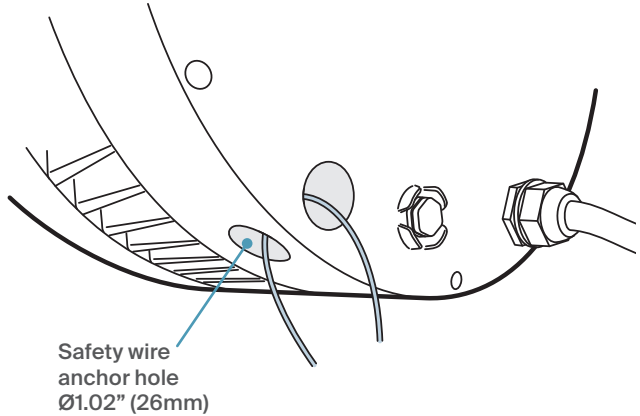

The yoke adjusters on each side of the Dyna Drum require a $\frac{5}{16}$ " (8mm) hex key to focus the fixture.

A useful angle chart is provided on each side to assist with initial adjustment.

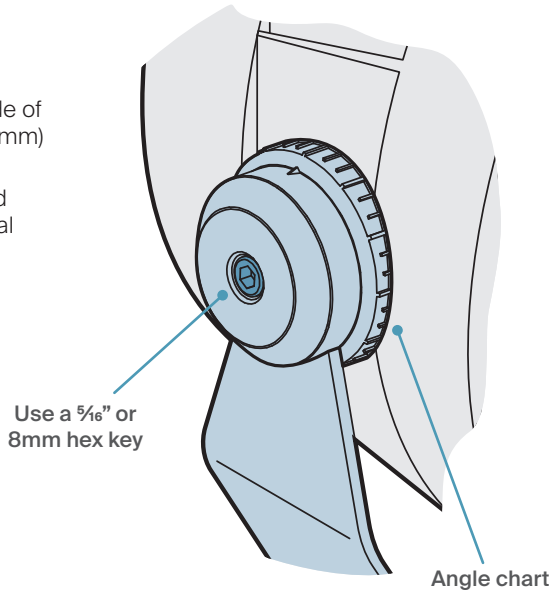

When installing each Dyna Drum fixture, ensure that the surface is level and that nothing is protruding to damage the mounting yoke. The yoke has multiple mounting holes and is designed to be surface mounted. Approved mounting surfaces include steel, aluminum, concrete or wood structures. Bolts or screws (not supplied) should be suitable for the surface (and the weight of the fixture) and ensure a secure mount for the fixture.

Using a tenon mount

Optional tenon mounts are available for use when a Dyna Drum needs to be mounted **on top** of a vertical pole. Tenon mounts are available for use with 2" and 4" poles of sufficient rigidity for the weight of the fixture.

IMPORTANT: Tenon mounts are suitable only for vertical pole mounting where the fixture sits on top of the pole. Tenon mounts must NEVER be used to hang a Dyna Drum below a pole.

To use a tenon mount

- 1 Slide the tenon mount onto the vertical pole and secure using the two bolts on the side (6mm hex key required).
- 2 Fix the Dyna Drum to the tenon mount using the supplied main bolt ($\frac{1}{16}$ " 17mm A/F wrench required) and pan control bolt ($\frac{1}{4}$ " 6mm hex key required) as shown right.
- 3 Use a suitable silicone sealant to cap off the cable access holes to prevent water ingress.

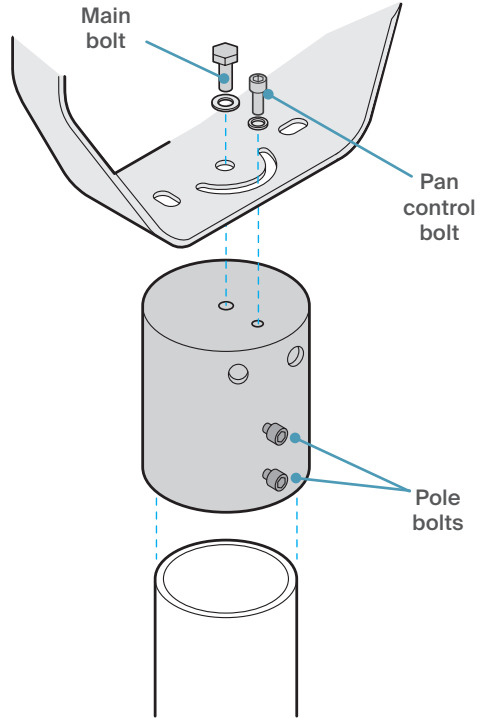

Using a pipe clamp

Optional pipe clamps are available to mount Dyna Drum fixtures on either 2" (50mm) or 4" (100mm) tubes and poles.

IMPORTANT: Ensure the pipe and its mountings have sufficient load capacity for the Dyna Drum fixture(s) to be mounted.

To use a pipe clamp

- 1 Separate the two halves of the clamp, if they are already bolted together.
- 2 Place the two halves of the clamp around the pipe.
- 3 Use the two longer bolts, one from each side to join the two halves - see below about the correct use of the supplied washers.
- 4 Tighten the two main bolts evenly until the clamp is held firmly in place.
- 5 Use the two smaller bolts (with spring and standard washers) to fix the Dyna Drum yoke to one side of the clamp and tighten.

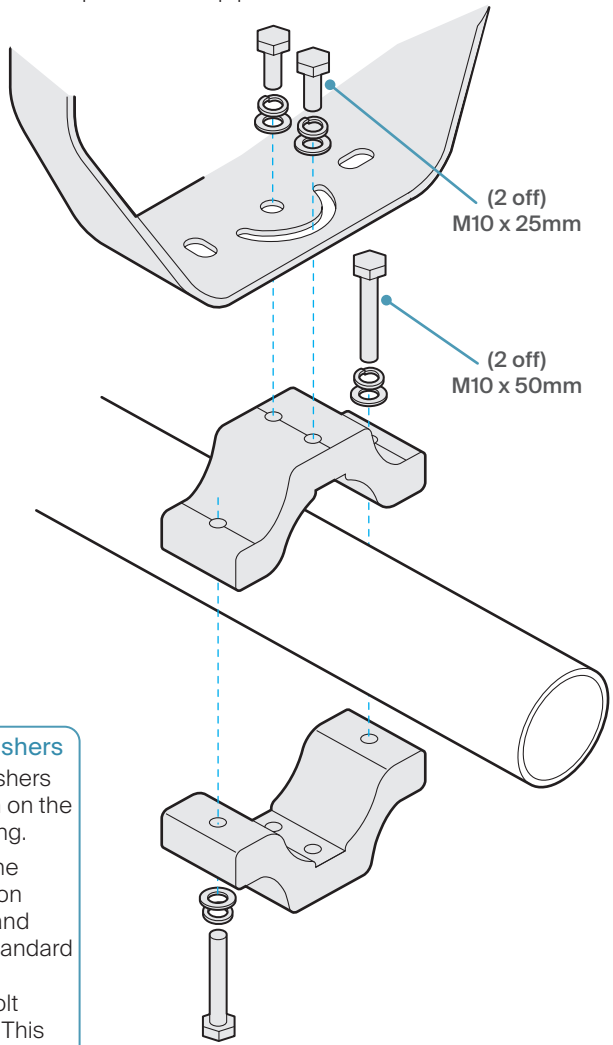

Using the supplied washers

The supplied spring washers help to maintain tension on the bolts to prevent loosening.

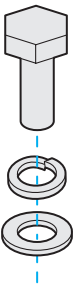

Always place the spring washer on each bolt first and then add the standard washer, before inserting the bolt into the clamp. This will prevent the steel spring washer from denting the softer aluminum body of the clamp.

Fitting a spread lens

Dyna Drums are usually supplied with a spread lens already fitted to suit each installation. Where necessary, these can be changed to suit different purposes. It is possible to use both a spread lens and a snoot; fit the lens first and then add the snoot.

Tip: Adding accessories is much easier if the Dyna Drum front face is pointing vertically upwards.

- 1 Using a 1/8" (3mm) hex key, remove the six bolts that secure the front ring and remove the ring.
- 2 Remove the protective films on each side of the lens and place it into the inner ring of the emitter face, with the frosted side of the lens must facing inwards towards the emitters.

To allow water drainage, the lens' rubber surround **must face outwards** and be placed so that two of the notches are vertically aligned.

- 3 Replace the front ring, then replace and tighten the six bolts evenly.

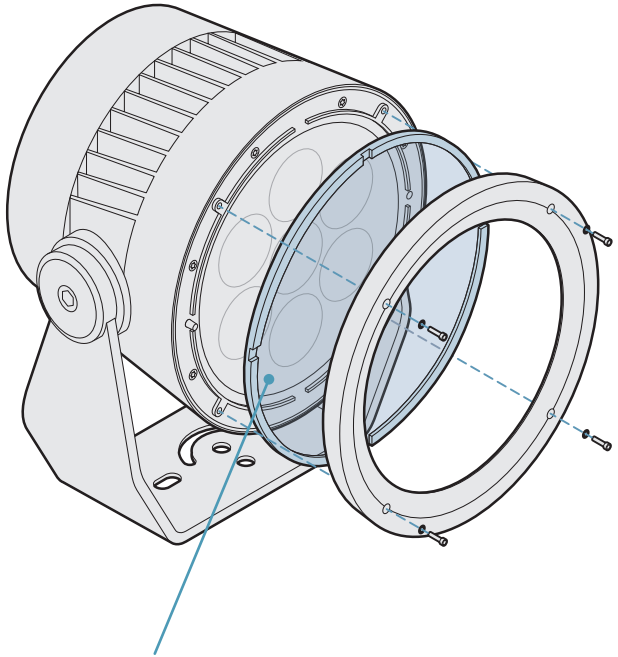

IMPORTANT: The frosted side of the lens must face inwards to the emitters.

Some spread lenses have asymmetric beam profiles, which will be labeled. For those options pay close attention to the lens orientation.

The rubber surround of each spread lens has a number of notches to allow water drainage. Ensure that one of the notches is located at the base of the fixture.

Fitting a half or full snoot

Snoots help to reduce or eliminate light spill into unwanted areas. The full and half snoots available from Acclaim Lighting are attached to the Dyna Drum units in the same way. It is possible to use both a spread lens and a snoot. Fit the lens first and then add the snoot.

Tip: Adding accessories is much easier if the Dyna Drum front face is pointing vertically upwards.

- 1 Using a 1/8" (3mm) hex key, remove the six bolts that secure the front ring.
- 2 Remove the front ring and place the snoot onto the front of the fixture. The snoot mounting holes must align with the same threads that are used by front ring. There are also two small holes either side of the snoot that must fit onto the small locating pins either side of the fixture.
- 3 Replace the front ring, then replace and tighten the six bolts evenly.

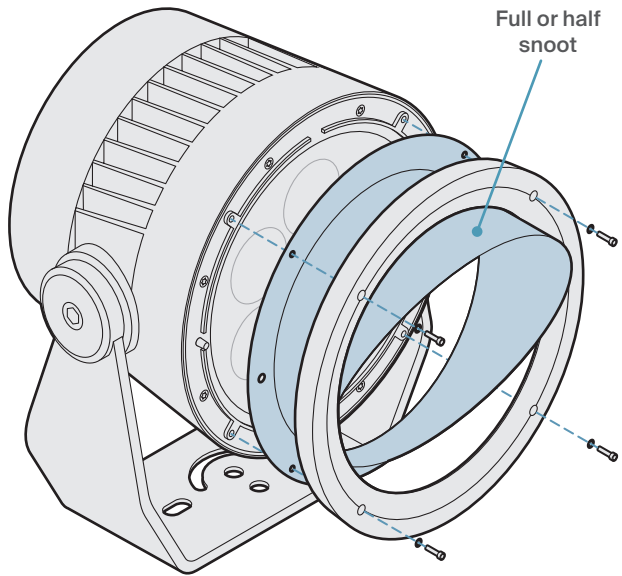

Fitting a wide snoot

Snoots help to reduce or eliminate light spill into unwanted areas. The wide snoot available from Acclaim Lighting replaces the front ring. It is possible to use both a spread lens and a wide snoot. Fit the lens first and then add the snoot.

Tip: Adding accessories is much easier if the Dyna Drum front face is pointing vertically upwards.

- 1 Using a $\frac{1}{8}$ " (3mm) hex key, remove the six bolts that secure the front ring.
- 2 Remove the front ring and place the wide snoot onto the front of the fixture. The wide snoot mounting holes must align with the same threads that were used by front ring. The front ring is not required while the wide snoot is fitted.
- 3 Replace and tighten the six bolts evenly.

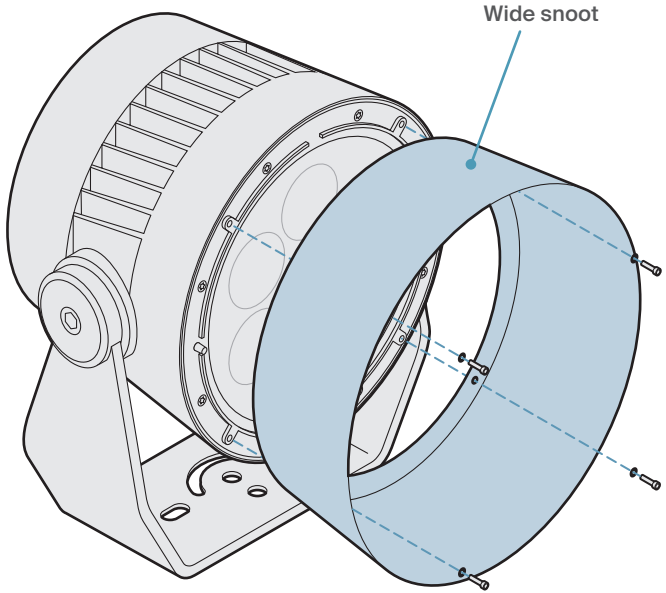

Fitting a wire guard

Wire guards help to prevent lens damage from stones, small masonry and other loose objects. It is possible to use spread lenses, wire guards and snoots together. Fit the lens first, then the wire guard and then add the snoot.

Tip: Adding accessories is much easier if the Dyna Drum front face is pointing vertically upwards.

- 1 Using a 1/8" (3mm) hex key, remove the six bolts that secure the front ring.
- 2 Remove the front ring and place the wire guard onto the front of the fixture. The wire guard mounting holes must align with the same threads that are used by front ring.
- 3 Replace the front ring, then replace and tighten the six bolts evenly.

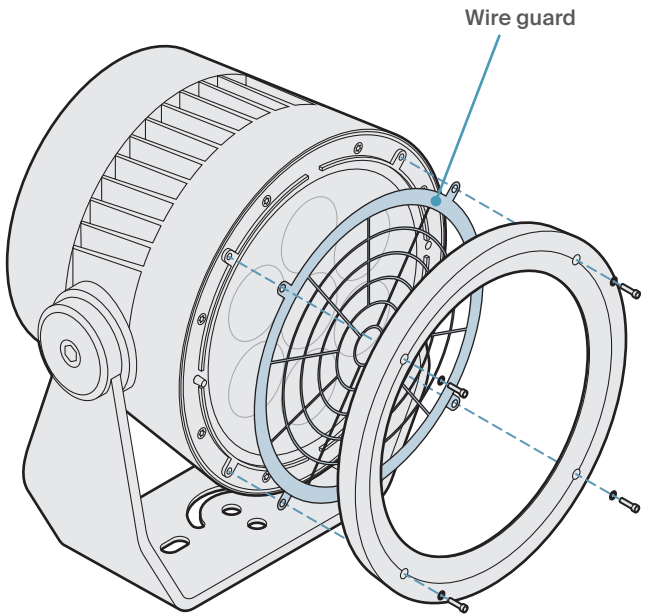

Swapping out a module or emitter head

Like all Acclaim Lighting products, Dyna Drum fixtures are designed and built for the long haul in professional environments. In the unlikely event of failure during the lifetime of a fixture, our **CoreSwap Technology** ensures that only the affected module need ever be swapped out. Before attempting a CoreSwap service, be sure to contact Acclaim technical support for further instructions.



To replace a module or emitter head

- 1 Ensure that power is isolated from the fixture.
- 2 Using a $\frac{1}{8}$ " (3mm) hex key, remove the four bolts (plus washers) evenly at the rear that secure the driver module to the emitter head.

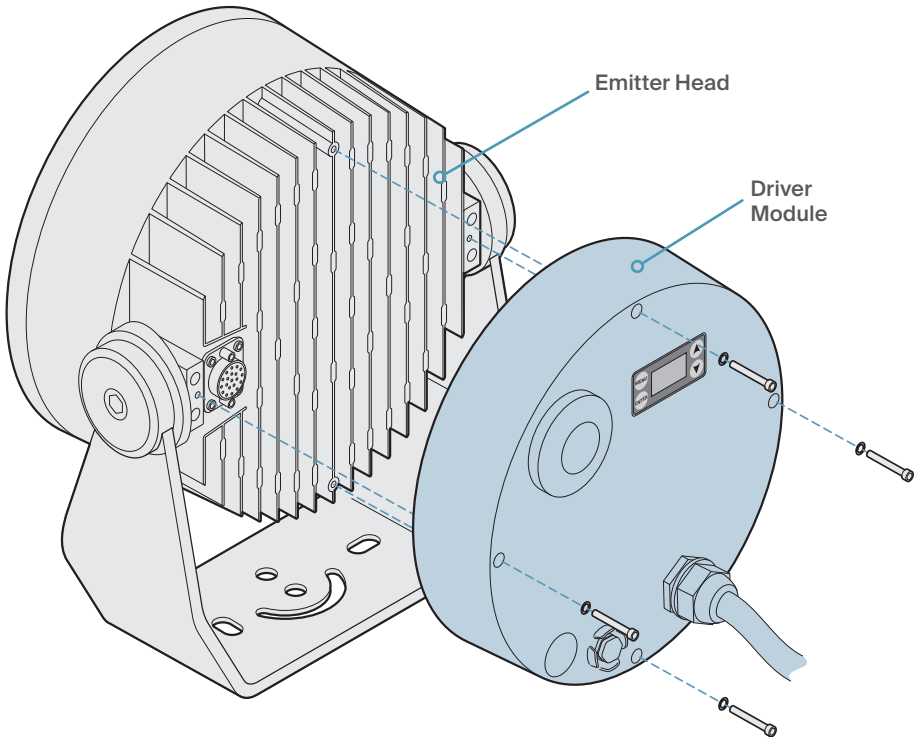

- 3 Carefully separate the driver module from the emitter head and substitute the module or head, as necessary.

Note: Driver modules are specific to the type of emitter head, ensure that a matching part is used in replacement (eg White, Color or SCS, standard output or high output, etc.).

- 4 With great care, attach the new part to the existing module or head, ensuring that the connectors and key holes are correctly aligned.
- 5 Replace and tighten the four bolts and washers evenly.

Power and control wiring

The supplied combined power and control feed cable (roughly 9 feet, 2.7m in length and with bare wire tails) attaches to the short lead at the rear of the fixture via IP67-rated composite connectors. If you need to connect the fixture to an Outdoor Link System configuration, use an optional OLS Link Cable (see pages 7 and 22) in place of the included bare wire feed cable.

The standard cord color designations are as follows:

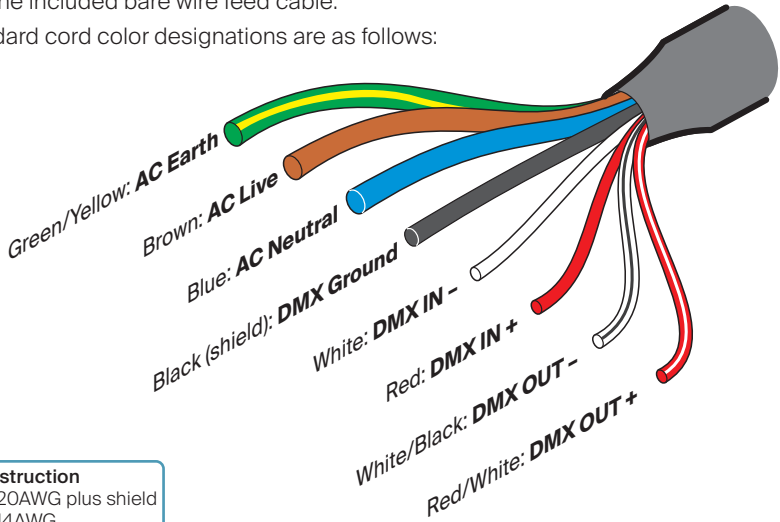

Cable construction

Signal: 4x 20AWG plus shield

Power: 3x 14AWG

208VAC phase-to-phase operation

Dyna Drum S3 fixtures are compatible with 208VAC phase-to-phase (star or delta) operation. Use the blue conductor to carry the second phase.

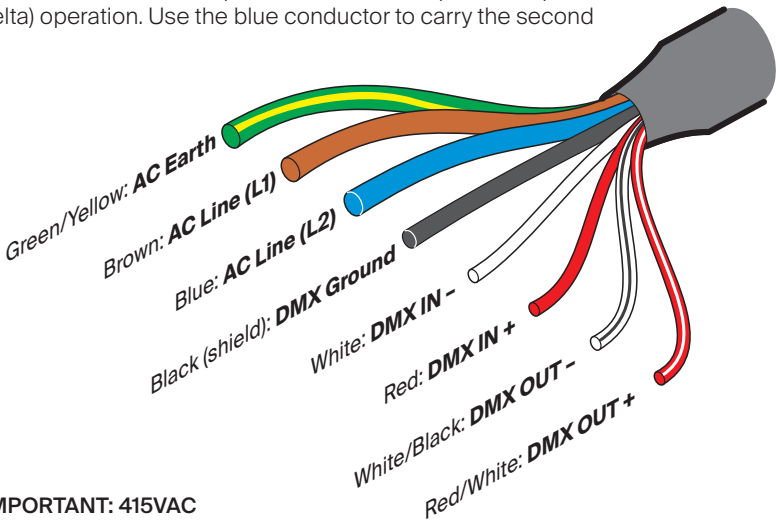

IMPORTANT: 415VAC
phase-to-phase supplies
(such as those used across
Europe) **must not** be used
with Dyna Drum fixtures.

Connect/disconnect

Note: Do not connect or disconnect the cord while power is applied.

The combined power and control cord attaches at the rear panel. Align and push the two IP67-rated connectors until a click is heard. Confirm the connection by gently pulling the connectors to ensure they have fully locked into place.

To disconnect: Twist and hold the blue collar while you withdraw the other connector.

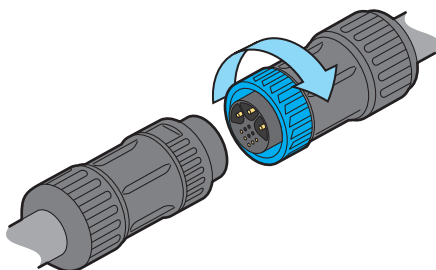

Power

The power requirements are as follows:

- Voltage: 100-277VAC 50/60Hz
- Power: 60W to 110W depending on model (see page 53)

Note: While Dyna Drum fixtures have built-in surge protection up to 10kV, 5kA I_n , 10kA I_{max} it is also important to take proper precautions for external surge protection, as control and power electronics can be damaged by major events.

Ensure that:

- the mains input is derived from a suitable overload-protected supply.
- all cable access points, plus the enclosure cover are correctly sealed.
- all local codes are followed during planning and installation.
- only suitable cable connectors are used within the junction box.
- connections are made, inspected and certified by a qualified electrician.

Wired DMX control

When connecting multiple fixtures (not using the Outdoor Linking System) connect the DMX output of the controlling device to the input wires of the first fixture and feed the output of that fixture to the next. The final fixture in the line should have a 120Ω terminating resistor connected between its DMX + (red/white) and DMX - (black/white) output lines:

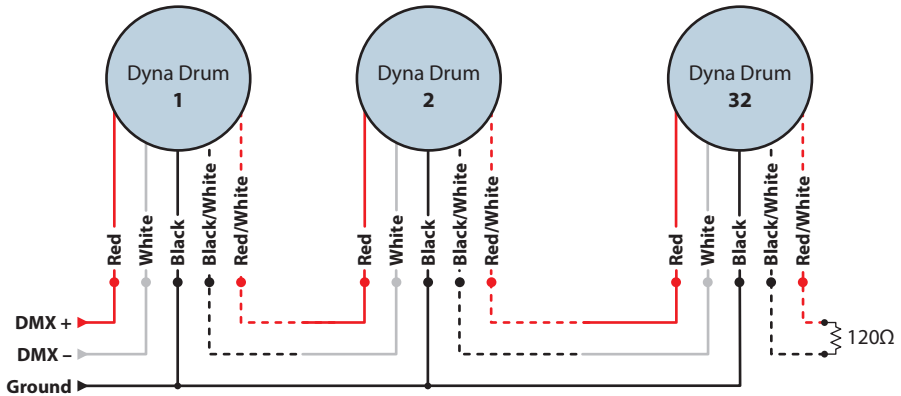

We recommend the following Belden signal cables for control links into the input feed:

- Indoor exposed or inside conduit above grade:Belden 9842
- Indoor plenum:Belden 82842
- Outdoor exposed, direct burial, or inside conduit below grade: Belden 3107DB

Suitable alternative cables must meet all of the following requirements:

- Construction: Shielded, twisted pair (or multi-pair).
- Impedance: Between 90 and 120Ω.
- Capacitance: 15pF or less.

Tips for achieving successful DMX control

- Do not exceed a total cable length of 1,500 ft (457m) without buffering.
- Do not exceed a total of 32 fixtures on a single line without buffering.
- Use only connection cables with a characteristic impedance of 120Ω, preferably where the DMX + and DMX - data lines are twisted around each other and the ground link exists as a coaxial screen surrounding the inner cores.
- Connect a 120Ω terminating resistor between the DMX + and DMX - output connections of the final fixture.
- Do not introduce a passive Y-split into the control cabling. If it is necessary to split the control link in order feed fixtures located in different directions, use a powered DMX splitter/buffer.
- Ensure that the DMX + and DMX - connections do not become crossed at any point.

Feed wiring protection: AJBOX1

The Acclaim Lighting AJBOX1 is a compact IP66-rated junction box, which provides separated AC power and DMX control inputs for connection to a combined feed cable. Internal surge protection up to 10kV max is built-in.

See page 22 for details about the Outdoor Linking System.

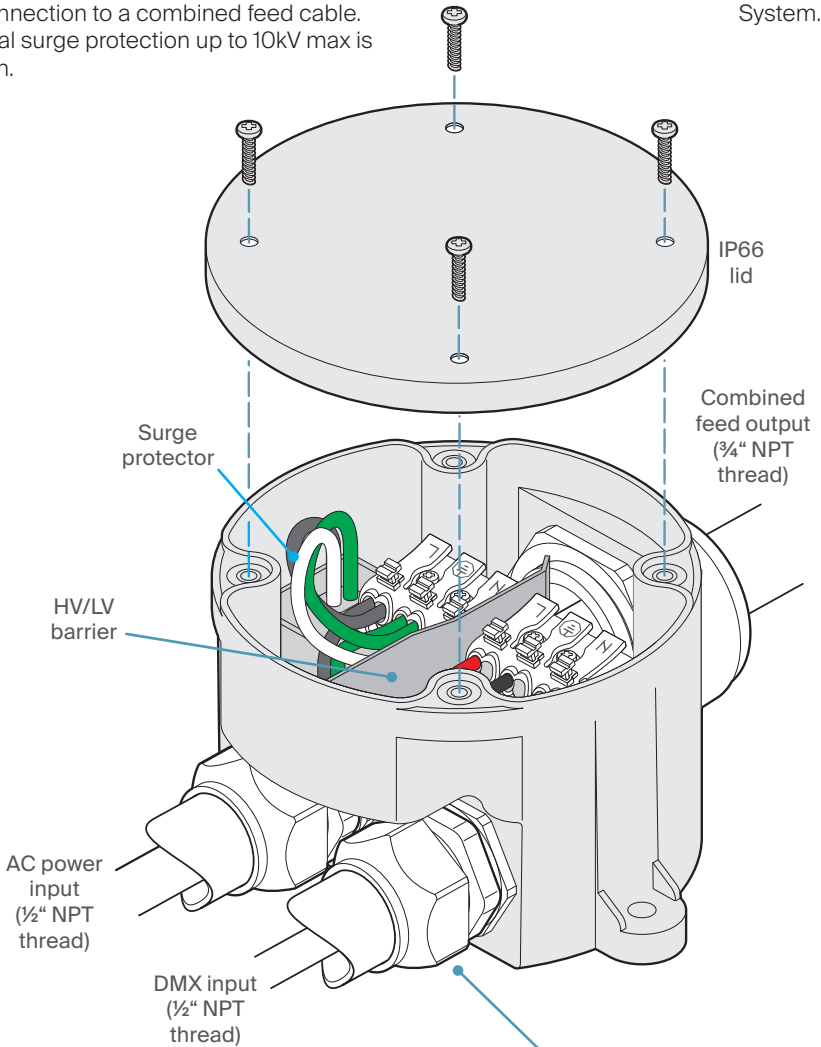

Input fixtures/glands

You will need to source 3rd-party conduit fixtures/cable glands for the inputs, as suits your installation. The large cable gland for the output is provided with the AJBOX1.

Shown here with cable gland inputs rather than conduit fixtures

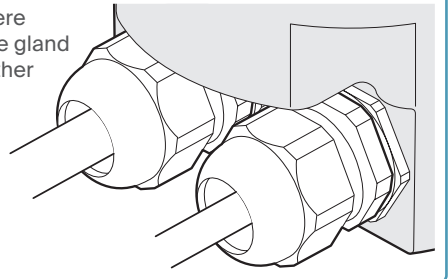

Feed wiring protection: AJBOX1-Extended

The Acclaim Lighting AJBOX1 Extended is a metal-bodied IP66-rated junction box, which provides separated AC power and DMX control inputs for connection to a combined feed cable or multiple outputs. Internal surge protection up to 10kV max is built-in as well as full optical signal isolation for the control data.

See page 22 for details about the Outdoor Linking System.

- 1 Remove the lid by removing the six recessed bolts using a 1/8" (3mm) hex key:

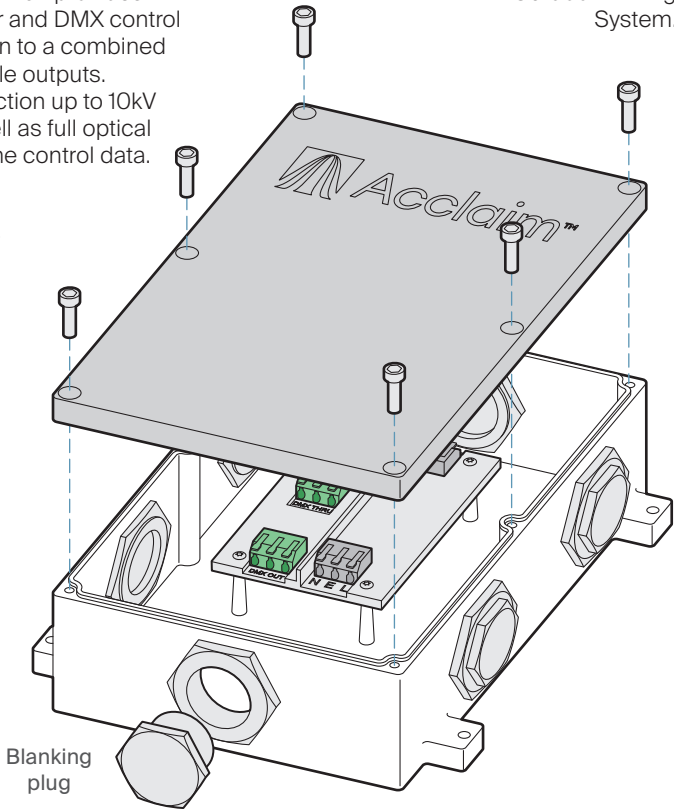

- 2 Remove blanking plugs, as required, using a 1 3/16" (30mm) spanner.
- 3 If required, gently prise off the rubber seals from the blanking plugs using a small flat blade screwdriver in order to install them on the cable glands/conduit fittings that you're using:

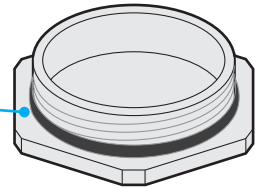

- 4 Add cable gland(s) or conduit fitting(s) as required (3/4" NPT thread):
- 5 Feed in your power and DMX inputs, plus the OLS feed cable.

Cable glands or conduit fittings (by others)

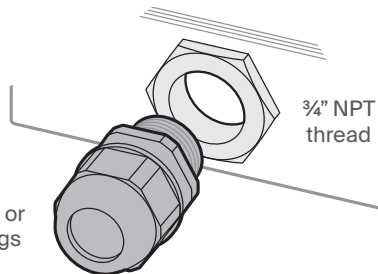

6 Connect your DMX control lines:

- Attach your control input to the green **DMX In** connector block.
- Optionally use the green **DMX Thru** connector block to continue your control run to other local devices. *Note: These contacts are directly linked to the DMX In connector block, they are NOT isolated.*
- Attach your main control output line to the green **DMX Out** connector block. These contacts are optically and galvanically isolated from the DMX In/Thru contacts while permitting DMX signals up to a full 44 frames per second to pass. *Note: RDM is not supported.*

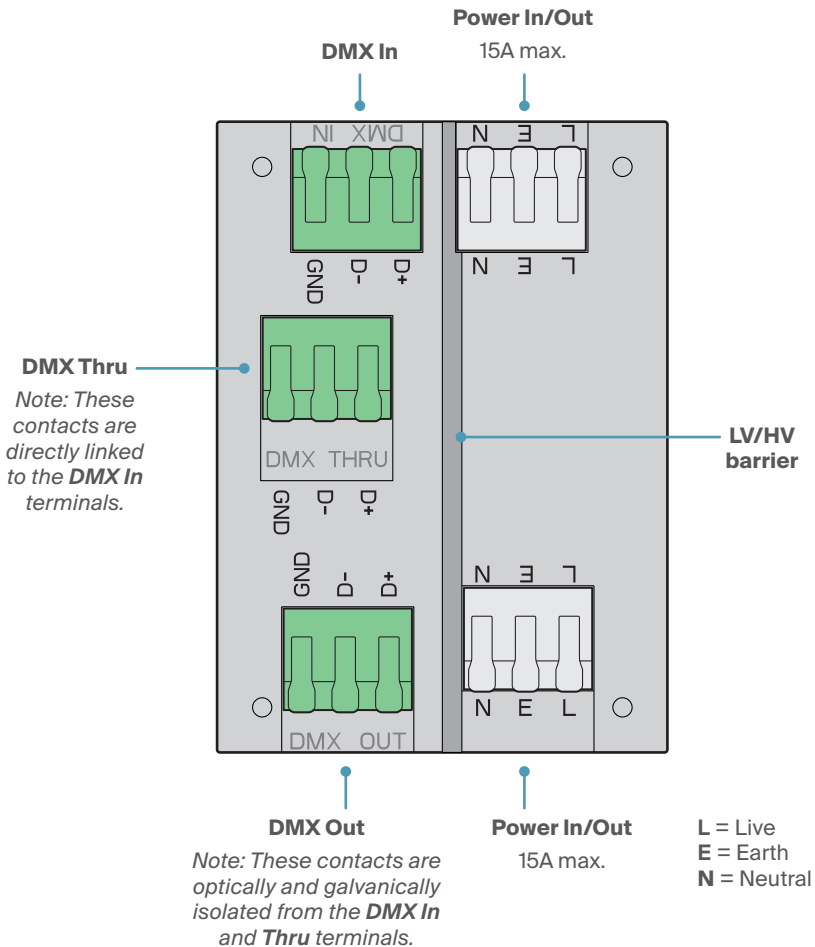

- 7 Connect a mains input to either of the two gray power connector blocks. A power input of 100-277VAC (50/60Hz) is required to energise the DMX isolation circuitry.
- 8 If required, connect a power output cable to the other gray connector. A maximum of 15A can pass between the two power connectors.
- 9 Refit and tighten the lid, while ensuring the lid's rubber seal is correctly in place.

Cabling with OLS

Dyna Drum S3 connectors are directly compatible with the Outdoor Link System. OLS greatly simplifies the task of distributing power and control to multiple fixtures.

OLS is a collection of feed and link cables (of various lengths) plus T-junctions and terminators, all utilizing IP67-rated connectors together with robust all-weather construction. The input to each stage is signified by a connector with a blue collar. The input and output connectors push together to mate quickly and securely; while a simple twist of the blue collar unlocks them instantly.

A typical configuration is shown on the next page.

For part numbers, see page 7.

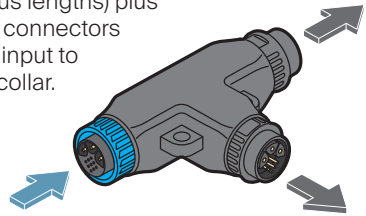

OLS limits

Feed current must not exceed 15A, which results in the realistic limits listed here:

Line voltage:	120VAC	230VAC	277VAC
Max power:	1,800W	3,450W	4,155W
Max run length:	150'	300'	350'
Max number of Dyna Drum S3 fixtures:			
High output:	16	30	32
Standard output:	30	32	32

Feed cable connections

The supplied feed cable provides bare tail connections suitable for termination within an all-weather junction box, such as the AJBOX1 (see page 19):

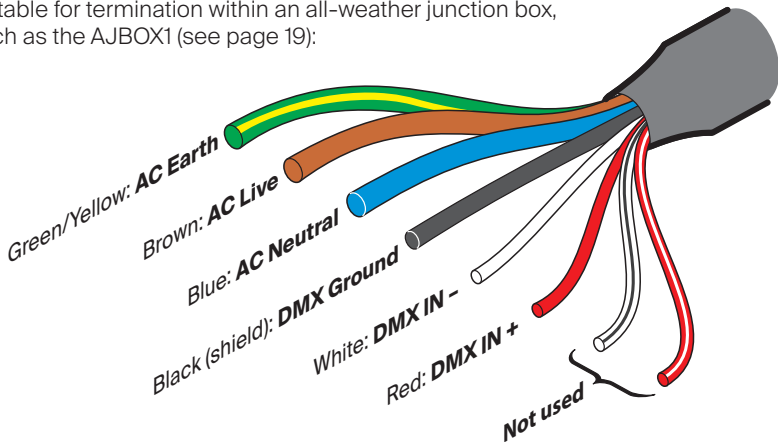

See also “208VAC phase-to-phase operation” on page 16.

Typical OLS configuration

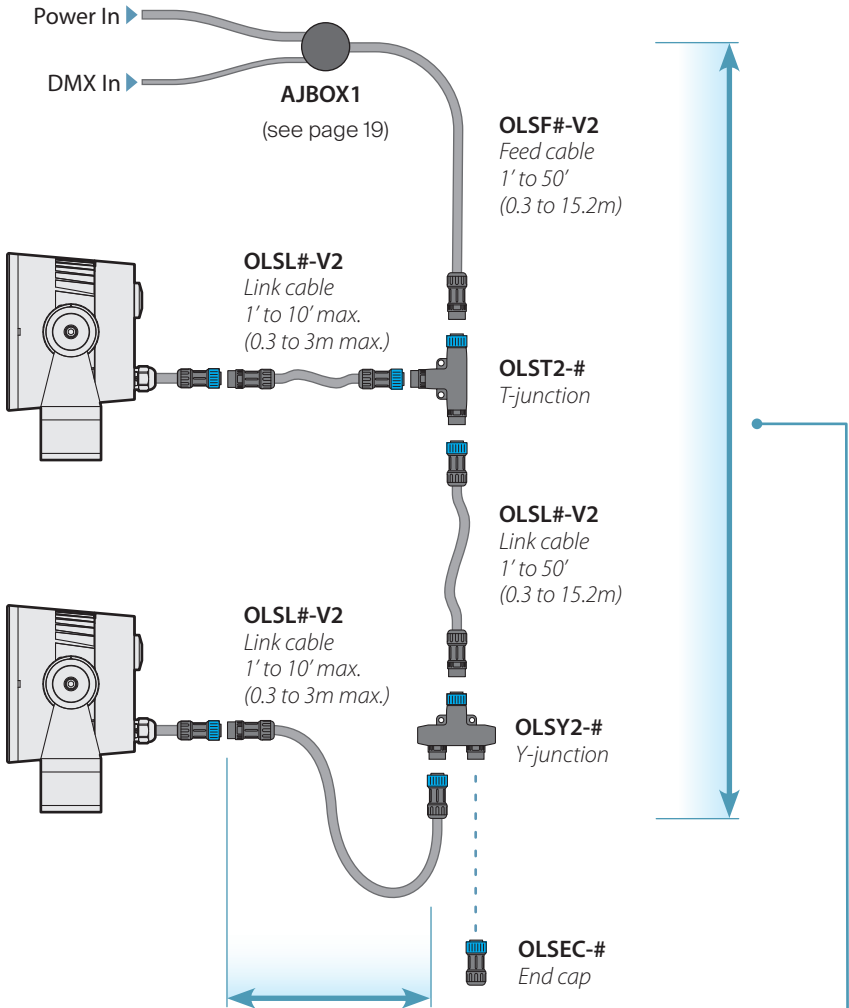

The total length from a T-junction to a fixture must not exceed 10' (3m) in length.

A terminator must be fitted to the final T-junction to simultaneously protect the live connections and correctly terminate the DMX control feed.

Maximum fixtures and cable lengths in a single OLS run:

120VAC: **30x SO** or **16x HO / 150'**

230VAC: **32x SO** or **30x HO / 300'**

277VAC: **32x SO** or **32x HO / 350'**

See also page 22.

Wireless DMX control

The embedded Aria X2™ wireless system allows you to control any number of Dyna Drum S3 fixtures that are within range of an Aria transmitter set to use the same wireless channel:

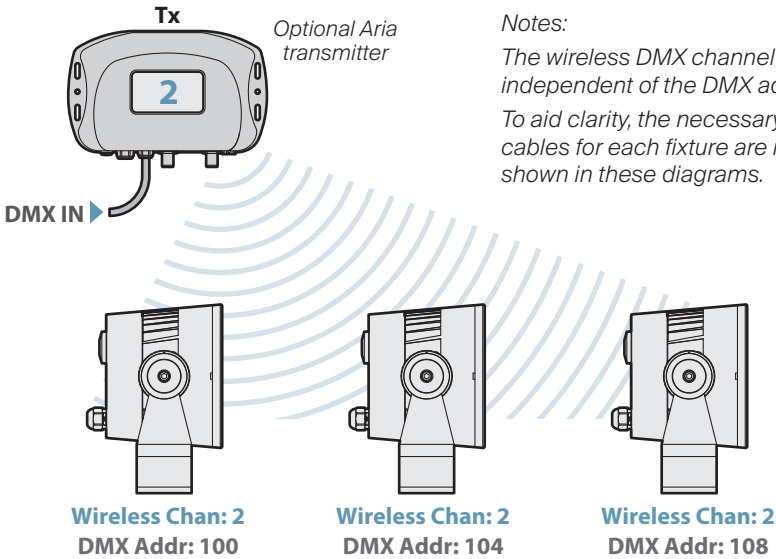

Notes:

The wireless DMX channel is totally independent of the DMX address.

To aid clarity, the necessary power cables for each fixture are not shown in these diagrams.

Using a Dyna Drum S3 as a wireless hub

When a Dyna Drum S3 fixture receives a wireless input (and it has no wired DMX input signal), it will automatically output the full received DMX universe on its output wires. This means that you can wire through and control up to 32 non-Aria DMX fixtures (such as Pixel Graze), or more, if an active repeater is used.

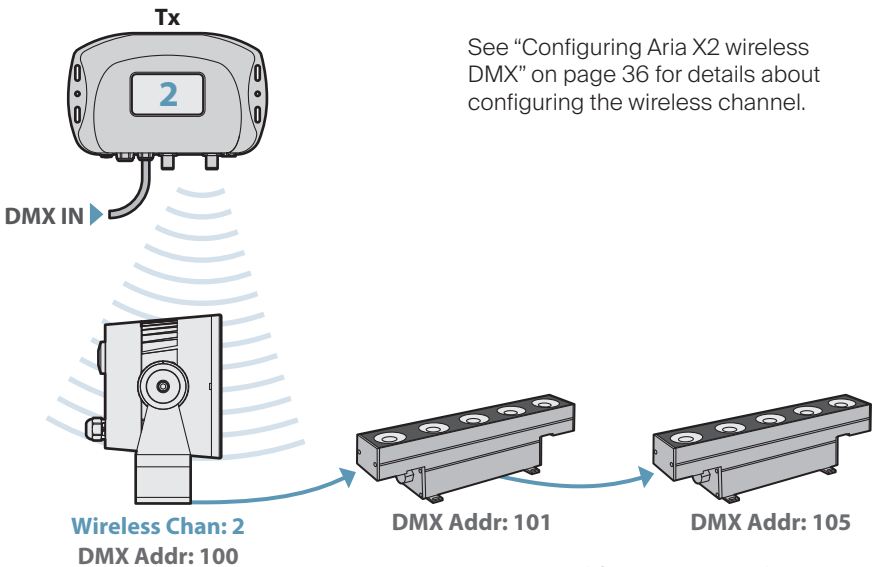

See “Configuring Aria X2 wireless DMX” on page 36 for details about configuring the wireless channel.

Non-Aria equipped fixtures (e.g. Pixel Graze)

Configuration

Uncovering the display

The user display and control buttons are protected behind a removable cover on the rear panel of the fixture.

To remove the display cover

- Use a 1/8" (3mm) Allen (hex) wrench to remove the two bolts holding the display cover.

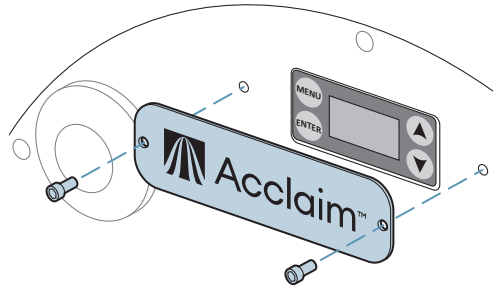

Operation of the fixture commences as soon as power is applied and the user display on the rear panel will first show **ACCLAIM Dyna Drum**. The display will then show the DMX address of the fixture and the selected channel mode - see page 33 for details), before blanking out. The fixture may or may not immediately show output from its emitters - this will depend upon the settings within the menu and/or control input.

Note: The sealed control buttons use capacitive sensors similar to your smartphone screen and will not respond to touch if you are wearing gloves.

Entering the menu

Press and hold the **MENU** button for roughly 7 seconds until the **Main Menu** entry is shown, then use the buttons to navigate the menu, as described below. The menu will automatically exit roughly six seconds after the last button press.

*Note: For a certain period after the menu has first been entered, and then exited, you will only need to tap any button to re-enter. After that period a locked symbol  will be shown and you will need to once again press and hold the **MENU** button for roughly 7 seconds to unlock it.*

Menu navigation

Once you have entered the menu, use the four control buttons to navigate around the menu and alter settings as necessary. The next page lists the main menu items.

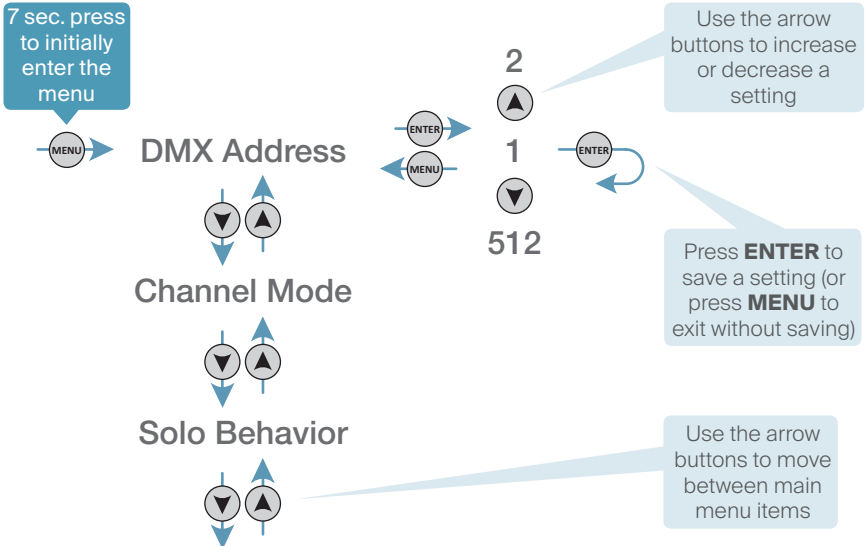

Main menu items

DMX Address	Sets the DMX start address for this fixture. Between one and eleven DMX addresses are required depending on the model and chosen channel mode. See page 27.
Channel Mode	Determines the way that DMX channels are aligned with the various functions of the fixture. See page 29.
Solo Behavior	Determines how the fixture should behave when there is no external control input. See page 34.
Photocell	Determines the configuration of the internal photocell automation features. See page 35.
Color Calibration	Allows you to disable the calibration settings that are programmed during manufacture. See page 27.
Wireless DMX	Determines the configuration of the internal wireless DMX receiver. See page 36.
BlueTooth Mode	Reserved for future use.
Mesh Mode	Reserved for future use.
Reset BLE Pin	Reserved for future use.
Security Mode	Reserved for future use.
White Balance	On color models, this allows you to bias the red, green and/or blue intensities in order to achieve a particular white balance that will be reproduced when RGB mixes are requested. See page 40.
System Test	Cycles through the various emitters to confirm correct operation. See page 39.
Internal Color	Allows you to mix a static color that will be shown depending on the status of the DMX input and the setting of the Solo Behavior option. See page 34.
Display Settings	Allows various changes to the user display, such as invert, backlight timeout, temperature units, etc. See page 39.
Frequency	Determines the base frequency used to control the LED emitters. This can be changed to eliminate visible flickering on video images. See page 38.
Gamma	Defines the relationship between the input control values and how the various LED emitters respond across their dimming ranges, from 0 to 100%. See page 38.
Fixture Information	Provides various details including the current LED temperature, usage times and firmware version. See page 28.
Factory Setting	Clears all user settings and returns all options to their default states. Also resets the DMX address to 1. See page 28.

Setting the DMX address

When external control (wired or wireless) is used, the DMX start address of the fixture needs to match the start address being used by the controlling device. Color fixtures use multiple DMX channels (for Red, Green, Blue and White), beginning with the one chosen here; white-only models require just one DMX channel (or two in 16-bit mode).

Notes:

- The DMX address can also be configured via RDM, see page 42.
- The DMX address is completely independent of the Aria X2 wireless radio channel setting.
- When a valid DMX input is attached to the Dyna Drum S3 fixture it will override any internal color output; additionally, the user display will show the configured DMX address.

To set the DMX address

- 1 Enter the user menu (see page 25).
- 2 Press **ENTER** to choose the *DMX Address* menu item.
- 3 Use the **▼** and **▲** buttons to choose a start address, from 1 to 512.
- 4 Press **ENTER** to save. The DMX start address is now fixed.

Color calibration

Dyna Drum color models undergo ColorSync calibration at our Los Angeles headquarters in order to maintain consistent color matching between fixtures. It is possible to disable the internally held calibration values with the possible result of noticeable differences in output between neighboring Unity fixtures.

To enable/disable color calibration

- 1 Enter the user menu (see page 25).
- 2 Use the **▼** or **▲** buttons to locate the *Color Calibration* option and press **ENTER**. The display will show the currently selected setting .
- 3 Use the **▼** or **▲** buttons to change the setting and press **ENTER**.

Returning to factory settings

This option returns the fixture to its default settings. The DMX address will be reset to 1.

To return to factory settings

- 1 Enter the user menu (see page 25).
- 2 Use the **▼** button to locate the *Factory Setting* option and press **ENTER**. The display will show *Reset to Factory Defaults*.
- 3 Press **ENTER**. The display will show *Are you sure?*
- 4 Use the **▼** button to show *Yes* and press **ENTER**.

Viewing fixture information

This option contains four useful information read-outs:

- **LED Temperature** - shows the current temperature measured at the centre of the LED emitter face. See page 39 for details about changing the temperature read-out units between °F and °C, and also about enabling over-temperature warnings.
- **Fixture Usage** - displays the total number of hours that the fixture has been powered on.
- **LED Usage** - displays the total number of hours that the LED emitters have been raised above 0% output.
- **Firmware Version** - displays the software versions for both the boot loader and the main application.

Note: All of these items are for information only, no changes are possible.

To view fixture information

- 1 Enter the user menu (see page 25).
- 2 Use the **▼** or **▲** buttons to locate the *Fixture Information* option and press **ENTER**.
- 3 Use the **▼** or **▲** buttons to locate the required read-out and press **ENTER**.

Selecting the channel mode

Numerous channel modes are available, as determined by the emitter types: WHITE, COLOR or SCS. In all cases, both 8-bit (single channel per color) and 16-bit (two channels per color) modes are provided. For 8-bit color mixing, the level for each color (between 0 and 100%), is determined in 255 steps; whereas two-channel 16-bit modes offer much greater color mixing precision by using 65,535 steps to determine each level between 0 and 100%.

Note: The channel mode can also be configured via RDM, see page 43.

To select the channel mode

- 1 Enter the user menu (see page 25).
- 2 Use the **▼** or **▲** buttons to locate the **Channel Mode** option and press **ENTER**. The currently selected mode will be shown.
- 3 Use the **▼** or **▲** buttons to display the required mode. The exact list of options is determined by the emitter types fitted in the fixture, eg *2CH-8BIT*, *4CH-8BIT*, etc.
- 4 Press **ENTER** to choose the displayed mode.

Channel modes for WHITE emitters

1-channel (8-bit mode)

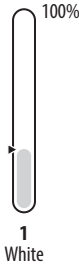

2-channel (16-bit mode)

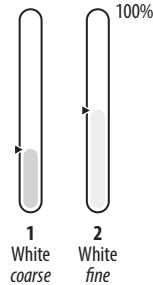

Channel modes for COLOR emitters

4-channel (8-bit mode)

Allows you to mix the required shade using the four distinct emitter colors. No intensity channel is used.

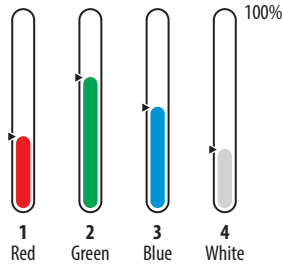

8-channel (16-bit mode)

Allows you to mix the required shade using the four distinct emitter colors - each controlled by two DMX channels to achieve a 16-bit value. No intensity channels are used.

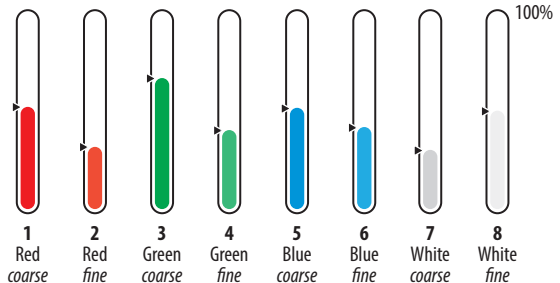

Channel modes for COLOR emitters (continued)

6-channel (8-bit) mode [QS & QW4]

Allows you to control the four emitter colors individually or alternatively to choose a particular color temperature of white. An intensity channel is provided.

Mixing colors individually

Use channels 1 to 4 to mix the required shade.

Use channel 6 to determine the overall output intensity.

Note: Channel 5 must be at zero.

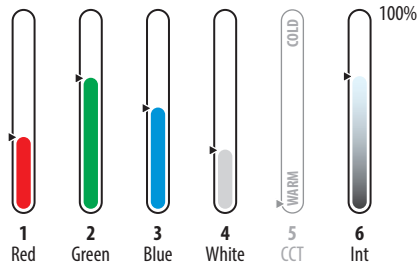

Choosing a temperature of white

Use channel 5 to select the required correlated color temperature (CCT) ranging from 1800K (at 1%) to 8000K (at 100%).

See page 49 for a full list of color temperatures and the DMX input values required at channel 5.

Use channel 6 to control the overall output intensity.

Note: When channel 5 receives any value other than zero, the input values of channels 1 to 4 will be ignored.

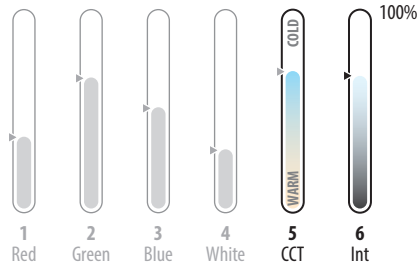

11-channel (16-bit) mode [QS & QW4]

Allows you to control the four emitter colors individually, using two DMX channels per color (to achieve a 16-bit value). For each color (and the intensity control), the first channel is the coarse value and the second provides the fine value. Use channels 10 and 11 to control the overall output intensity.

Note: Channel 9 must be at zero to allow color mixing. When channel 9 receives any value other than zero, the input values of channels 1 to 8 will be ignored.

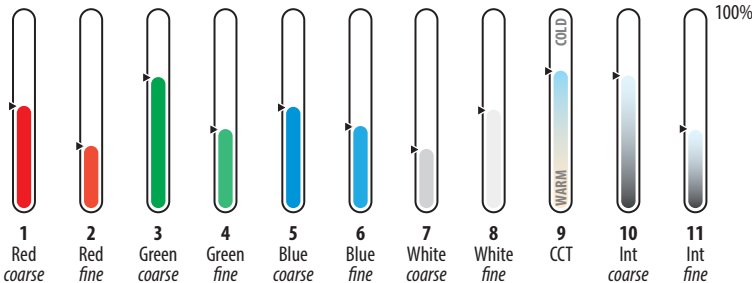

Choosing a temperature of white

Use channel 9 to select the required correlated color temperature (CCT) ranging from 1800K (at 1%) to 8000K (at 100%). See page 49 for a full list of color temperatures and the DMX input values that need to be presented at channel 9.

Channel modes for SCS emitters

2-channel (8-bit) Dynamic White mode

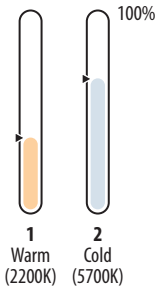

4-channel (16-bit) Dynamic White mode

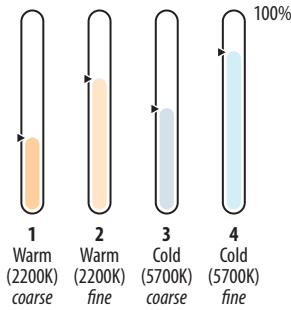

4-channel (8-bit) RGBW mode

Allows you to mix the required shade using the four distinct emitter colors. No intensity channel is used.

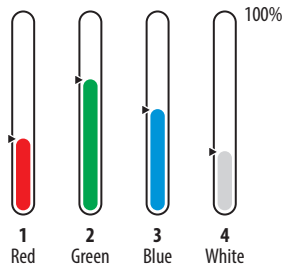

8-channel (16-bit) RGBW mode

Allows you to mix the required shade using the four distinct emitter colors - each controlled by two DMX channels to achieve a 16-bit value. No intensity channels are used.

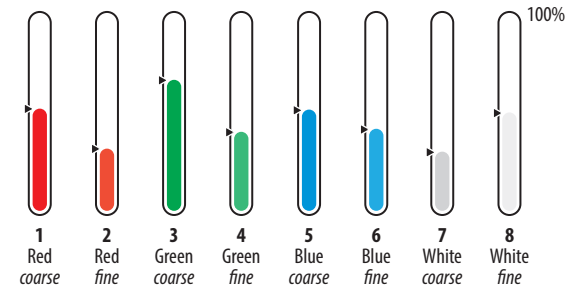

4-channel (8-bit) RGBA mode

Allows you to mix the required shade using the four distinct emitter colors. No intensity channel is used.

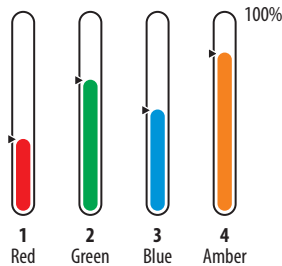

Channel modes for SCS emitters (continued)

8-channel (16-bit) RGBA mode

Allows you to mix the required shade using the four distinct emitter colors - each controlled by two DMX channels to achieve a 16-bit value. No intensity channels are used.

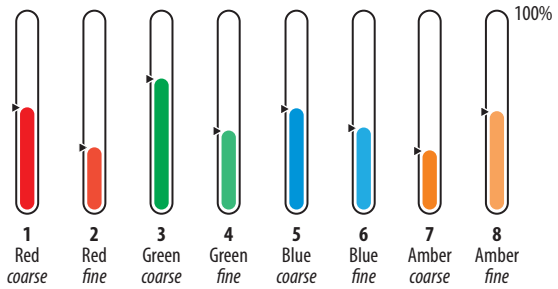

4-channel (8-bit) RGLB mode

Allows you to mix the required shade using the four distinct emitter colors. No intensity channel is used.

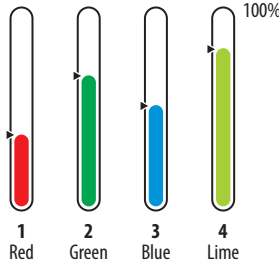

6-channel (8-bit) RGLB mode

Allows you to control the four emitter colors individually or alternatively to choose a particular color temperature of white. An intensity channel is provided.

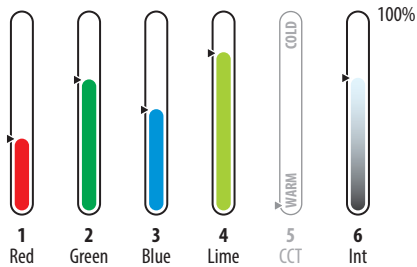

Mixing colors individually

Use channels 1 to 4 to mix the required shade.

Use channel 6 to determine the overall output intensity.

Note: Channel 5 must be at zero.

Choosing a temperature of white

Use channel 5 to select the required correlated color temperature (CCT) ranging from 1800K (at 1%) to 8000K (at 100%).

See page 49 for a full list of color temperatures and the DMX input values required at channel 5.

Use channel 6 to control the overall output intensity.

Note: When channel 5 receives any value other than zero, the input values of channels 1 to 4 will be ignored.

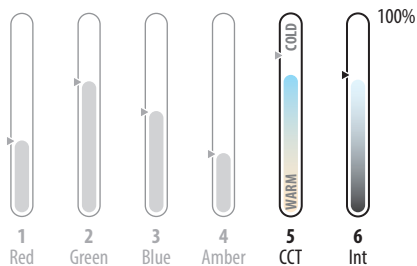

Channel modes for SCS emitters (continued)

8-channel (16-bit) RGLB mode

Allows you to mix the required shade using the four distinct emitter colors - each controlled by two DMX channels to achieve a 16-bit value. No intensity channels are used.

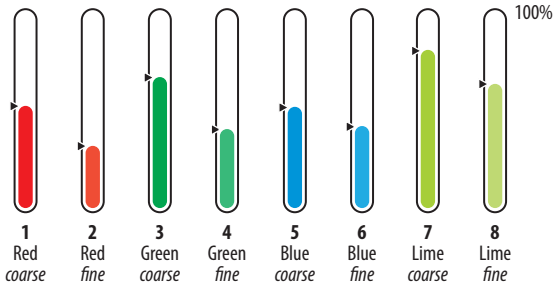

11-channel (16-bit) RGLB mode

Allows you to control the four emitter colors individually, using two DMX channels per color (to achieve a 16-bit value). For each color (and the intensity control), the first channel is the coarse value and the second provides the fine value. Use channels 10 and 11 to control the overall output intensity.

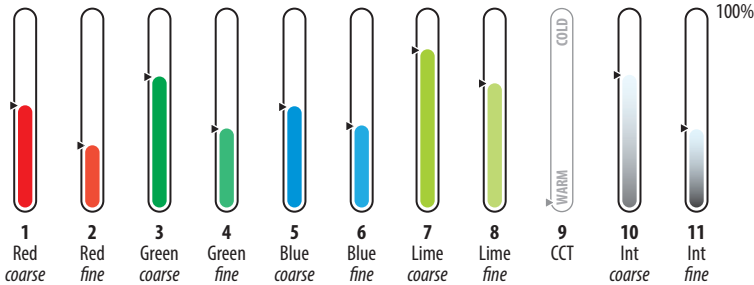

Note: Channel 9 must be at zero to allow color mixing. When channel 9 receives any value other than zero, the input values of channels 1 to 8 will be ignored.

Choosing a temperature of white

Use channel 9 to select the required correlated color temperature (CCT) ranging from 1800K (at 1%) to 8000K (at 100%). See page 49 for a full list of color temperatures and the DMX input values that need to be presented at channel 9.

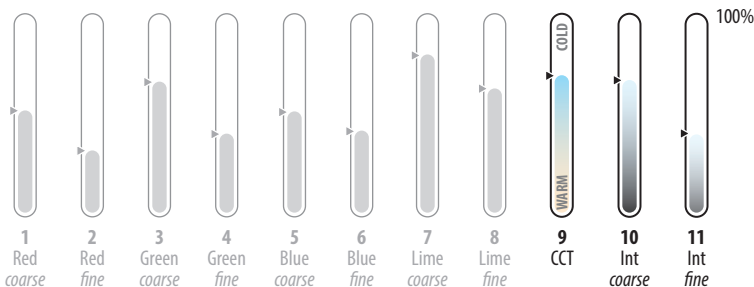

Determining solo behavior

You can choose how the fixture should behave when it is running solo, either because an external control input is not being used at all or because a connection has been temporarily lost. There are three solo behavior choices:

- **Black Out** - In this mode, when no external control is present, the emitter output will be extinguished.
- **Internal Color Mode** - In this mode, when no external control is present, the fixture can be made to show a pre-programmed static color or dimming level. Ensure that an internal color mix or dimmed white output setting is stored within the *Internal Color* option. For details about creating static color mixes, see below.
- **Hold Last DMX Value** - In this mode, when no external control is present, the emitter output will remain as per the last received instruction.

To determine the solo behavior

- 1 Enter the user menu (see page 25).
- 2 Use the **▼** or **▲** buttons to locate the *Solo Behavior* option and press **ENTER**. The user display will show the currently selected solo behavior mode.
- 3 Use the **▼** or **▲** buttons to show the required solo behavior mode and then press **ENTER** to enable it.

Setting an internal color

This option allows you to mix a static color (or choose a white dimming level on white models) which will be displayed whenever the following two criteria are met:

- The *Solo Behavior* option is set to *Internal Color Mode* (see above) and,
- There is no DMX input signal.

To set an internal color

- 1 Enter the user menu (see page 25).
- 2 Use the **▼** or **▲** buttons to locate the *Internal Color* option and press **ENTER**.
- 3 On color models, use the **▼** or **▲** buttons to locate the required color sub-option (white models have a single dimmer channel).
- 4 Press **ENTER**.
- 5 Use the **▼** or **▲** buttons to change the dimming setting and press **ENTER**.
- 6 On color models, repeat steps 3 to 5 until the required overall color mix is achieved.
Note: Ensure the Dimmer setting is above zero.

Using the automation features (Photocell)

The fixture includes two related features which allow you to automate standalone operation:

- The built-in photocell can trigger a pre-mixed color/white output when the ambient light conditions fall below a pre-determined level.
- The auto shutoff timer determines how long the fixture should remain outputting after it has been triggered by the photocell.

For the photocell feature to successfully output a color/white mix, ensure:

- There is no external DMX signal.
- A color mix (or selected white) output setting is stored within the *Internal Color* option - see page 34.
- The Solo Behavior is set to *Internal Color Mode* - see page 34.

To configure Photocell Automation

- 1 Enter the user menu (see page 25).
- 2 Use the **▼** or **▲** buttons to locate the *Photocell* option and press **ENTER**. The display will show *Photocell On/Off*.
- 3 Press **ENTER**. If the display shows *Off*, use the **▼** or **▲** buttons to change the entry to *On* and press **ENTER**.
- 4 Use the **▼** or **▲** buttons to show *Photocell Sensitivity* and press **ENTER**. The display will show the ambient light level at which the fixture should begin outputting (*100* is the most sensitive to light). Some experimentation will be required to determine the optimum setting (the default is *70*).
- 5 Use the **▼** or **▲** buttons to show the required sensitivity setting (from 0 to 100) and press **ENTER**.
- 6 Use the **▼** or **▲** buttons to show *Photocell Timer* and press **ENTER**. The display will show the number of hours that the fixture is currently configured to show output, once triggered by the photocell.
- 7 Use the **▼** or **▲** buttons to show the required number of hours (from 1 to 24) and press **ENTER**.

Configuring Aria X2 wireless DMX

Each Dyna Drum fixture incorporates an internal Aria™ X2 wireless DMX receiver so that it can be remotely controlled by an optional Aria X2 transmitter.



The Aria X2 standard provides a choice of three separate wireless frequency bands:

- **2.4GHz** - (2404-2480MHz) - This licence-free radio band is approved for use in most countries worldwide and provides good results in most areas. *Note: The X2 2.4GHz band is not supported by the first generation (single band) Aria transmitters.*
- **900MHz (NA)** - (902-928MHz) - This licence-free radio band is approved for use across the Americas, Greenland and some of the eastern Pacific Islands (see map below), overseen by the FCC. **Important:** This option can only be used in countries located within **ITU Region 2**.
- **900MHz (EU)** - (863-870MHz) - This licence-free radio band is approved for use across the Europe, Africa, the Commonwealth of Independent States, Mongolia and the Middle East west of the Persian Gulf, including Iraq (see map below). **Important:** This option can only be used in countries located within **ITU Region 1**.

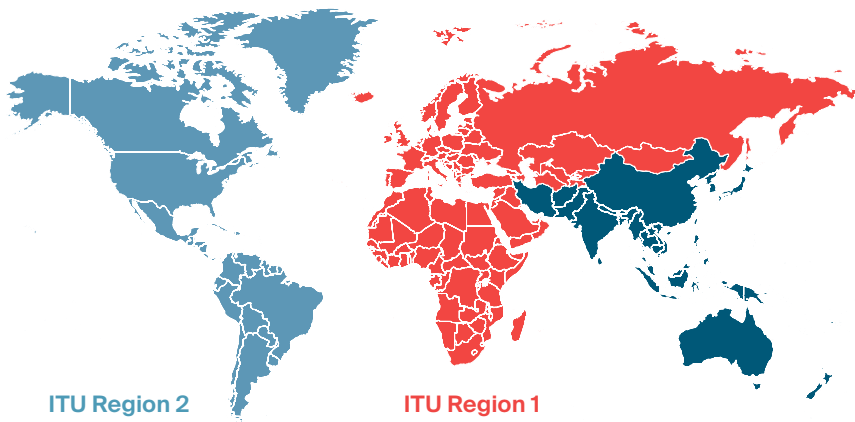

Choosing the appropriate frequency band

We strongly recommend you carry out a radio spectrum survey prior to installation in order to determine any potential sources of temporary or permanent interference.

The **2.4GHz** band provides good results, particularly for outdoor installations. However, this frequency range can become congested in areas where other devices, particularly Wi-Fi equipment are also in use. You are advised to use the 2.4GHz band unless you encounter frequency congestion or issues interference by obstacles. See also “Optimizing signal strength via channel selection (2.4GHz)” on page 50.

If your installation is located in ITU regions 1 or 2, then the **Sub-GHz (900MHz)** bands become a possible alternative. Their lower frequency, longer wavelength transmission characteristics can provide improved obstacle penetration than the 2.4GHz band and they can be advantageous for indoor installations where Wi-Fi use is prevalent. Both Sub-GHz bands are susceptible to interference from other license-exempt transmitting devices using the same frequency space.

At present, two distinct Sub-GHz bands are supported. A single channel is available for use only in ITU Region 1 (at 866.6MHz) while ten channels (from 906 to 924MHz) are cleared for use in ITU Region 2 See also “Aria X2 Sub-GHz (900MHz) bands” on page 51.

To configure wireless DMX

Wireless configuration consists of three parts: Enable the wireless option, choose the required frequency band and choose a suitable channel within the band.

- 1 Enter the user menu (see page 25).
- 2 Use the **▼** or **▲** buttons to locate the **Wireless DMX** option and press **ENTER**.
The display will show **Wireless On/Off**.
- 3 Press **ENTER**. If the display shows **Off**, use the **▼** or **▲** buttons to change the entry to **On** and press **ENTER**.
- 4 Use the **▼** or **▲** buttons to show **Wireless Mode** and press **ENTER**.
- 5 Use the **▼** or **▲** buttons to show the required frequency band: **2.4GHz, 900MHz (NA)** or **900MHz (EU)** and press **ENTER**. See "Choosing the appropriate frequency band" on page 36.
- 6 Use the **▼** or **▲** buttons to show the matching channel selector: **2.4GHz Channel, 900MHz NA Channel** or **900MHz EU Channel** and press **ENTER**.
- 7 Use the **▼** or **▲** buttons to choose the required radio channel to match that used by the Aria transmitter:
 - 2.4GHz - Channels 0 to 15 available,
 - 900MHz (NA) - Channels 0 to 9 available,
 - 900MHz (EU) - No channel selection necessary. When this frequency is selected, the channel number is ignored because only one channel is possible in this band.

Note: Ensure the Aria X2 transmitter and any other related fixtures are set to use the same wireless frequency band and channel.
- 8 When the appropriate channel is displayed, press **ENTER**.

Notes:

- Although Aria X2 wireless settings can be configured via RDM over a wired DMX link, the wireless link itself does not support RDM (which requires 2-way communication).
- The Aria X2 wireless radio channel setting is completely independent of the DMX address.
- If a valid wired DMX control input is applied to the fixture, it will take precedence over the Aria X2 wireless control link.

Adjusting the gamma setting

Like most light sources, the manner in which LED emitters operate means they exhibit a non-linear response. This means that to achieve changes in output levels which look proportional and correct to the eye (and particularly when filmed), it is necessary to vary the rate of change at the lower and upper ends of the dimming range in comparison to the middle. This is achieved using an in-built dimming response curve.

As high specification fixtures, Dyna Drums provide the option to adjust the nature of the dimming response curve so that the emitters (for every color) respond differently for given control input levels. This is referred to as the *Gamma* setting. By default, the gamma setting is set to **Off** to produce a mild and progressive response. If the gamma setting is enabled and increased, from **2.0** through to **2.8**, you will notice a higher response to dimming changes, particularly at the lower end. The graph above simulates the effects upon dimming (applied equally to each color) of choosing the various gamma setting options.

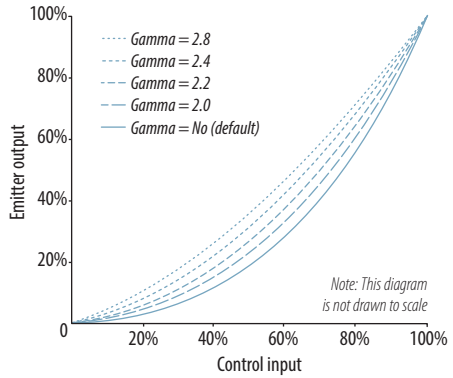

To adjust the Gamma setting

- 1 Enter the user menu (see page 25).
- 2 Use the **▼** or **▲** buttons to locate the **Gamma** option and press **ENTER**. The current Gamma setting will be shown.
- 3 Press **ENTER** and then use the **▼** or **▲** buttons to show the required gamma setting.
- 4 Press **ENTER** to set the new gamma value.

Adjusting the PWM frequency

As with most LED fixtures, Dyna Drums dim their emitters by using a technique called *Pulse Width Modulation (PWM)*. This involves switching the emitters on and off at a high frequency and then varying the lengths of the respective on and off periods according to the required dimming level. The frequencies used all lie beyond the ability of the naked eye to distinguish the on/off transitions, however, some camera systems can detect flickers at certain frequencies. To solve this potential issue, Dyna Drums allow you to change the default 1200Hz base PWM frequency to lower, or much higher ones that respond better to particular camera issues. Options range from 900 to 25,000Hz.

To adjust the PWM frequency setting

- 1 Enter the user menu (see page 25).
- 2 Use the **▼** or **▲** buttons to locate the **Frequency** option and press **ENTER**. The current PWM base frequency will be shown.
- 3 Press **ENTER** and then use the **▼** or **▲** buttons to show the required frequency.
- 4 Press **ENTER** to set the new value.

Changing the display settings

This option contains four settings related directly to the user display:

- **Display Invert** - allows you to invert the text on the user display so that it reads correctly when the fixture is mounted upside-down.
- **Backlight Timeout** - determines whether the user display should automatically blank out when it is not being used, or should remain on permanently to allow the DMX address to be seen at all times. When set to Off, the time-out feature will be disabled and the display will not blank out.
- **Temperature Unit** - allows you to change between °F and °C when displaying readings in the *Fixture Information > LED Temperature* section.
- **Display Warning** - when set to On, a warning will appear on the display if the internal temperature becomes too high, either due to the external environment or an internal issue. The message reads: *Temperature warning - please check fixture.*

Note: In addition to showing a warning, the fixture will protect its emitters by automatically reducing output to 50% if the maximum allowable operating temperature is exceeded. If the over-temperature condition persists for more than 10 minutes, the fixture will close itself down.

To change display settings

- 1 Enter the user menu (see page 25).
- 2 Use the **▼** or **▲** buttons to locate the *Display Settings* option and press **ENTER**.
- 3 Use the **▼** or **▲** buttons to locate the required sub-option and press **ENTER**.
- 4 Use the **▼** or **▲** buttons to change the sub-option setting and press **ENTER**.

Running a system test

This option assists in testing all of the emitters. When engaged, the emitters will flash on and off. Color models will cycle in turn through the various emitter colors.

To run a system test

- 1 Enter the user menu (see page 25).
- 2 Use the **▼** or **▲** buttons to locate the *System Test* option and press **ENTER**. The fixture will change between emitter outputs. The user display will flash *Testing.....* while the test proceeds.
- 3 Press either the **MENU** or the **ENTER** buttons to halt the test.

Setting a white balance

Note: White balance is only possible on Dyna Drum Color and SCS models.

White balance is useful when your Dyna Drum installation will be required to regularly present particular shades of white using the R, G, B emitters, (plus the white emitters, if necessary). Using the white balance feature you can 'bias' particular colors so that when the R, G and B channels are all brought up, your pre-programmed bias will achieve, for example, a balanced warm white derived from a significant red output, with a moderate green output, while the blue is scaled back.

To achieve identical white balance across a collection of fixtures, you will need to program the same settings on each Dyna Drum unit.

To set a white balance

- 1 Enter the user menu (see page 25).
- 2 Use the **▼** or **▲** buttons to locate the *White Balance* option and press **ENTER**.
You now have access to the separate *Red*, *Green* and *Blue* options, which are all set to 255 by default.
- 3 Use the **▼** or **▲** buttons to choose a color and press **ENTER**.
- 4 Use the **▼** or **▲** buttons to reduce the chosen color from 255 down to a minimum of 125 to reduce the intensity of that color, and press **ENTER** to save.
- 5 Repeat step 4 for each color that needs to be biased to achieve the required balance.

To cancel a white balance

- 1 Enter the user menu (see page 25).
- 2 Select the *White Balance* option. In turn visit each color and ensure that they are all returned to 255.

Configuration via RDM

The use of RDM (Remote Device Management) with the Dyna Drum series is optional and allows the following tasks to be completed remotely without having to visit each fixture:

- DMX address see page 42
- DMX personality see page 43
- Aria X2 wireless receiver see page 44
- Solo behavior/internal color see pages 45 and 46
- Automation features see page 47

Various third party DMX/RDM tools are available; we recommend the DMXcat-E™ from City Theatrical™ for this task.

Note: It is not possible to carry out RDM configuration on fixtures via the Aria™ X2 wireless DMX link.

To configure other options (see page 42 for setting the DMX address)

- 1 Connect the DMXcat-E to the DMX input line of the Dyna Drum installation.
- 2 In the DMXcat app on your phone, link to the DMXcat-E unit and then choose the **RDM Controller** tool:

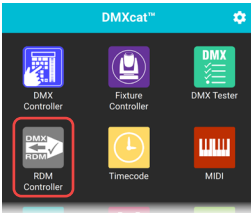

- 3 The DMXcat-E will search for RDM devices and after a short while it will display a list of all located fixtures:

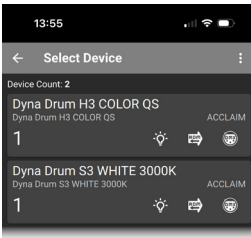

- 4 Tap the **RDM** icon for the required fixture to view its Device Details, then scroll to the right side of the option headings at the top of the page and tap the **Manuf. Settings** entry:

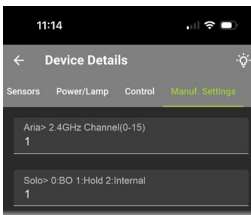

Setting the DMX address via RDM

To set the DMX address using the DMXcat-E

- 1 Connect the DMXcat-E to the DMX input line of the Dyna Drum installation.
- 2 In the DMXcat app on your phone, link to the DMXcat-E unit and then choose the RDM Controller tool:

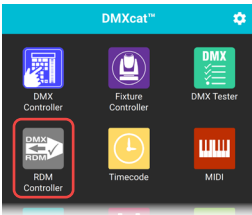

- 3 The DMXcat-E will search for RDM devices and after a short while it will display a list of all located fixtures:

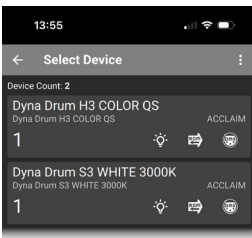

- 4 Tap the list entry for the required fixture to view the Quick Settings popup:

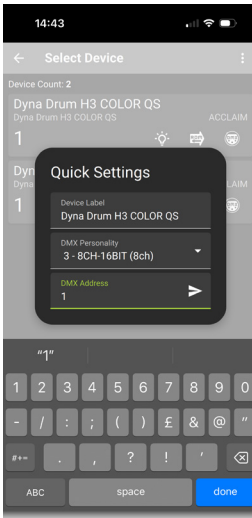

- 5 Tap the **DMX Address** entry, enter the required address and tap the ► icon.

Setting the DMX personality (channel mode) via RDM

For details about the available DMX personalities, please see pages 29 to 33.

To set the DMX personality using the DMXcat-E

- 1 Connect the DMXcat-E to the DMX input line of the Dyna Drum installation.
- 2 In the DMXcat app on your phone, link to the DMXcat-E unit and then choose the **RDM Controller** tool:

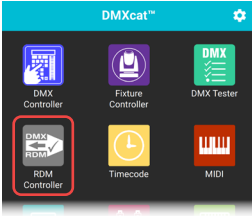

- 3 The DMXcat-E will search for RDM devices and after a short while it will display a list of all located fixtures:

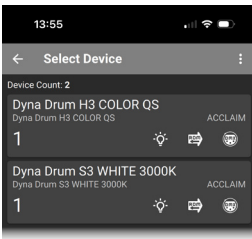

- 4 Tap the list entry for the required fixture to view the Quick Settings popup:

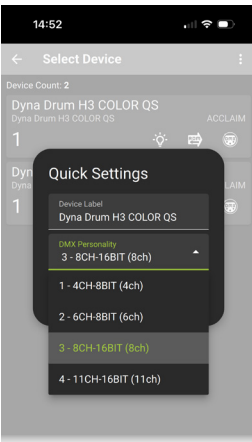

- 5 Tap the **DMX Personality** entry, tap the required mode from the drop down list and then tap the ➤ icon.

Configuring Aria X2 wireless via RDM

To configure wireless DMX using the DMXcat-E

1 On your DMXcat-E device, display the **Manuf. Settings** page (see page 41):

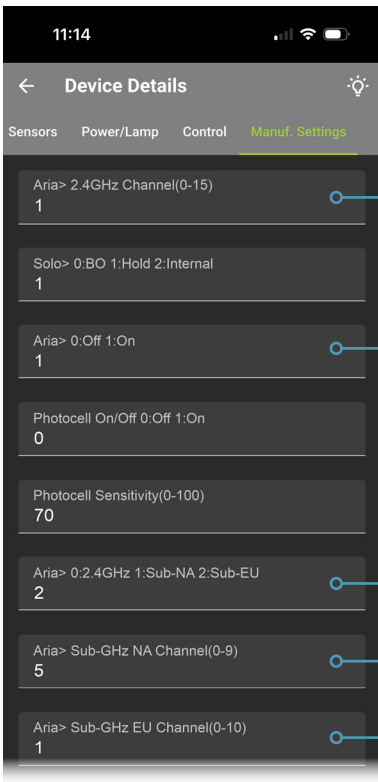

(C) Tap to choose a 2.4GHz channel

(A) Tap to enable/disable the Aria X2 wireless receiver

(B) Tap to choose the wireless band: 2.4GHz (opt 0) or Sub-GHz NA (opt 1)

(C) Tap to choose a Sub-GHz NA channel

(C) Tap to choose a Sub-GHz EU channel

2 Within this page, you can configure all aspects of Aria X2 operation. There are numerous aspects to consider, so it is best to approach the configuration in this order:

(A) Enable the X2 wireless receiver - ensure this option is set to '1'.

(B) Choose the appropriate wireless band. There are three to choose from (see 20 for more detail):

- 2.4GHz (setting 0) - can be used in most countries worldwide.
- Sub-GHz NA (setting 1) or Sub-GHz EU (setting 2) - varying channels can be used in ITU regions 1 and 2 (see map on page 36).

(C) Depending on the chosen band, choose a wireless channel that matches the channel set on your transmitter, in either the 2.4GHz or Sub-GHz options.

IMPORTANT: These restrictions apply when using the Sub-GHz option:

- Sub-GHz NA channels 0 to 9 can be used only in ITU region 2 (the Americas, Greenland and some of the eastern Pacific Islands).
- Sub-GHz EU the channel number is ignored as only one channel is possible. ITU region 1 (Europe, Africa, the Commonwealth of Independent States, Mongolia and the Middle East, west of the Persian Gulf, including Iraq).

3 For each option that you change, tap the ► icon to save your choice.

Determining the solo behavior via RDM

You can choose how the fixture should behave when it is running solo, either because an external control input is not being used at all or in reaction to the control signal being temporarily lost. There are three solo behavior choices:

- **BO (Black Out)** - (setting **0**) In this mode, when no external control is present, the emitter output will be extinguished.
- **Hold (Last DMX Value)** - (setting **1**) In this mode, when no external control is present, the emitter output will remain as per the last received instruction.
- **Internal** - (setting **2**) In this mode, when no external control is present, the fixture will output the mix that has been pre-determined using the **Internal Color** setting (see page 46).

To determine the solo behavior using the DMXcat-E

1 On your DMXcat-E device, display the **Manuf. Settings** page (see page 41):

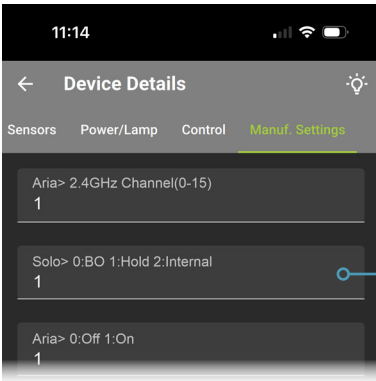

Tap to determine the solo behavior

2 Tap the **Solo> ...** entry and set the solo behavior mode as required:

- Enter **0** to set **BO (Black Out)** mode.
- Enter **1** to set **Hold (Last DMX Value)** mode.
- Enter **2** to set **Internal** mode.

3 Tap the  icon.

Setting an internal color via RDM

This option allows you to mix a static color which will be displayed whenever the following two criteria are met:

- The **Solo** option is set to **Internal** (see page 45) and,
- There is no DMX input signal.

To set an internal color using the DMXcat-E

1 On your DMXcat-E device, display the **Manuf. Settings** page (see page 41):

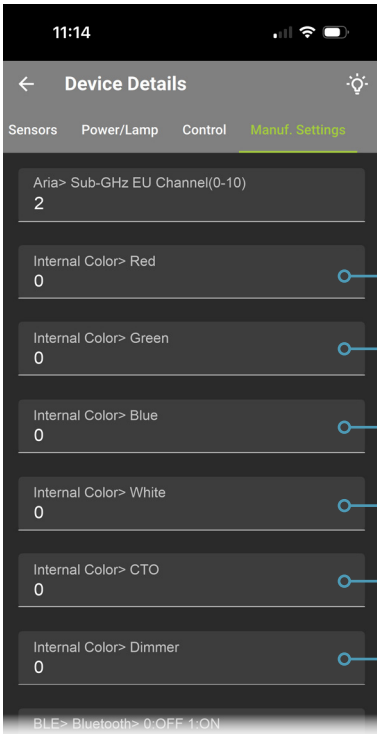

Tap to determine a color mix

Tap to choose a particular color temperature of white

Tap to determine the intensity setting (must be above 0 to see light output)

2 Toward the middle of the list you will see a collection of **Internal Color> ...** options.

- Tap and configure each color individually to create the required output mix.
- Alternatively, to select a particular color temperature of white, set a value for the **Internal Color> CCT** option (the red, green, blue, amber and lime values will be ignored if this CCT value is above 0).
- Ensure that the **Internal Color> Dimmer** value is above 0.

Note: Dyna Drum White models have just a single Dimmer option.

3 For each option that you change, tap the  icon to save your choice.

Setting the automation features (photocell) via RDM

The fixture includes two related features that allow you to automate standalone operation:

- The in-built photocell can enable fixture output (at 100%) when the ambient light level falls below a pre-determined level.
- The auto shutoff timer determines how long the fixture should remain outputting after it has been triggered by the photocell.

These automated features operate only in standalone mode, i.e. with no external DMX control input.

To set the automation features using the DMXcat-E

1 On your DMXcat-E device, display the **Manuf. Settings** page (see page 41):

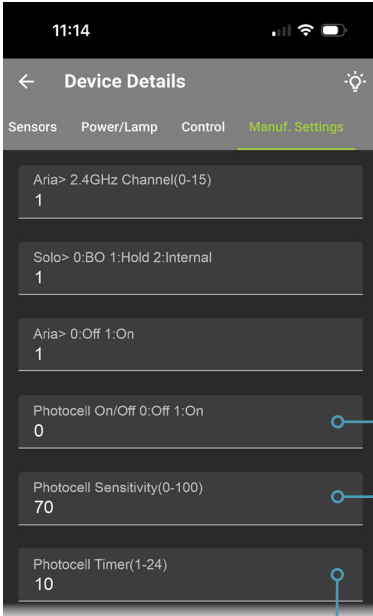

Tap to enable/disable the photocell feature

Tap to set the required ambient light level at which the fixture should begin outputting (**100** is the most sensitive to light). Some experimentation will be required to determine the optimum setting (the default is 70).

Tap to determine the number of hours (starting from the photocell trigger) that light output should continue before being extinguished. The options range from **1** to **24** hours (the default is 10 hours).

Note: For the photocell feature to operate, ensure that no DMX signal is received by the fixture. Color models will output all colors at 100% when triggered.

Further information

Troubleshooting

No light output is visible when expected.

- Check that power is correctly applied to the fixture and that there is no damage to the power input cord.
- Use the menu to perform an emitter test.
- Use an RDM tool to perform an emitter test.
- Use the menu to check the internal temperature of the fixture.
- If external DMX control is being used, check that the DMX address set within the fixture matches that being output by the controlling source device.
- If external DMX control is being used, check the DMX output near to the source to confirm a valid signal is being originated. When a valid DMX input is attached to the Dyna Drum fixture, the user display will show the configured DMX address.
- If external DMX control is being used, check that the DMX + (hot) and DMX - (cold) lines have not been crossed.
- If the Internal Color mode is being used, check that the static color or white-only output has been correctly programmed (see page 40) and that the appropriate solo mode is selected (see page 34).
- If Aria X2 wireless DMX control is being used, check that the fixture is set to the same wireless channel/band as the transmitter (the wireless channel is independent of the DMX address). Try changing the transmitter and receiving fixture(s) to different (but equal) wireless channels to check for clear space in the radio spectrum from interference by other devices, such as WiFi.
- Dyna Drum S3 fixtures are not directly compatible with first generation Aria wireless transmitters; you will need to use an Aria X2 transmitter. Where a mixture of older generation wireless fixtures need to be mixed with 3rd generation Dyna Drums, use an Aria X2 IPH Bridge transmitter, which can output both the original and new wireless signals.

Dimming and/or chase changes are jerky when using Aria X2.

- Check for WiFi sources near to the transmitter or receiver devices. Try changing the transmitter and receiving fixture(s) to different (but equal) wireless channels to check for clear space, from interference by other devices, in the radio spectrum.

Correlated color temperature (CCT) selection [SCS RGBL and Color QS/QW4 emitter models only]

This chart lists the DMX values which must be presented at the CCT channel in order to achieve an output with a particular correlated color temperature (CCT) of white.

DMX input value	Color temperature	DMX input value	Color temperature
0	Off	125-128	4900K
001-004	1800K	129-132	5000K
005-008	1900K	133-136	5100K
009-012	2000K	137-140	5200K
013-016	2100K	141-144	5300K
017-020	2200K	145-148	5400K
021-024	2300K	149-152	5500K
025-028	2400K	153-156	5600K
029-032	2500K	157-160	5700K
033-036	2600K	161-164	5800K
037-040	2700K	165-168	5900K
041-044	2800K	169-172	6000K
045-048	2900K	173-176	6100K
049-052	3000K	177-180	6200K
053-056	3100K	181-184	6300K
057-060	3200K	185-188	6400K
061-064	3300K	189-192	6500K
065-068	3400K	193-196	6600K
069-072	3500K	197-200	6700K
073-076	3600K	201-204	6800K
077-080	3700K	205-208	6900K
081-084	3800K	209-212	7000K
085-088	3900K	213-216	7100K
089-092	4000K	217-220	7200K
093-096	4100K	221-224	7300K
097-100	4200K	225-228	7400K
101-104	4300K	229-232	7500K
105-108	4400K	233-236	7600K
109-112	4500K	237-240	7700K
113-116	4600K	241-245	7800K
117-120	4700K	246-250	7900K
121-124	4800K	251-255	8000K

Optimizing signal strength via channel selection (2.4GHz)

Aria™ X2 wireless transceivers can use radio frequencies contained within the Industrial Scientific and Medical (ISM) band that runs between 2.4GHz and 2.5GHz. As one of the few license-free radio bands agreed upon in most countries, many other devices also use this band, most notably WiFi. Aria X2 units use the 2.4GHz band in a different manner than WiFi and the two can coexist. However, where distances between Aria X2 units are great and WiFi access points are reasonably close, then interference can become an issue. See also “Aria X2 Sub-GHz (900MHz) bands” on page 51.

WiFi uses the IEEE802.11 standard, which divides the ISM band into 13 (sometimes 14) channels, each of which is 22MHz wide. However, the channels overlap and so cannot all be used simultaneously. Hence, most WiFi access points settle upon channels 1, 6 and 11 to avoid any overlap:

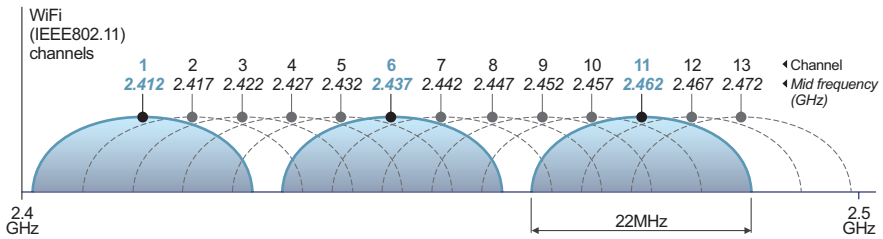

Aria X2 uses the IEEE802.15.4 standard, with channels that are 3MHz in width and do not overlap. Many Aria X2 channels do, however, coincide with the common WiFi channels. The notable exceptions are Aria X2 channels 4, 9, 14 and 15 which fall into the gaps between the most commonly used WiFi channels:

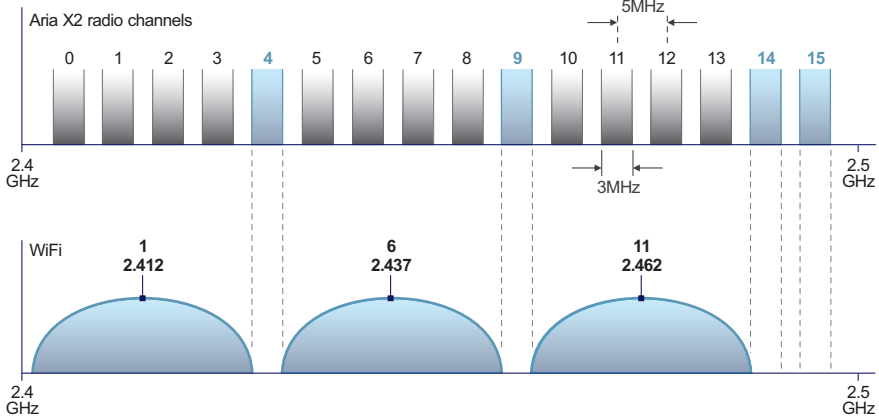

Before installing Aria wireless devices, such as the Dyna Drum S3, we strongly recommend you carry out a radio spectrum survey to determine any potential sources of temporary or permanent interference issues.

If you have control over the nearest WiFi access points, it is suggested that you lock them down to one or more of the common channels (to prevent them from roaming) and select radio channels that sit comfortably alongside.

Note: The Aria X2 channel notations (0 to 15) are directly equivalent to the IEEE802.15.4 channels 11 to 26, inclusive.

Aria X2 Sub-GHz (900MHz) bands

In addition to using the 2.4GHz ISM band, Aria X2-equipped devices can also take advantage of lower frequency bands that are cleared for use in certain geographical regions. The lower frequency, longer wavelength transmission characteristics of the Sub-GHz bands can provide improved obstacle penetration over the 2.4GHz band and they can be advantageous for indoor installations where Wi-Fi use is prevalent. However, they can be susceptible to interference from other license-exempt transmitting devices using the same frequency space. As always, a radio spectrum survey will help to identify the best option within any given environment.

At present, two distinct Sub-GHz bands are supported. A single channel is available for use only in ITU Region 1 (at 866.6MHz) while ten channels (from 906 to 924MHz) are cleared for use in ITU Region 2:

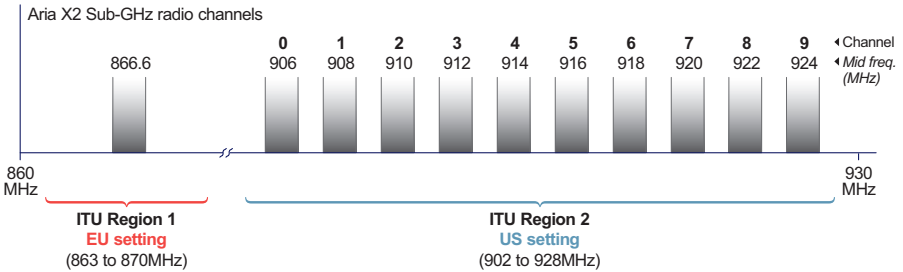

The map below shows the geographical spread of the ITU regions:

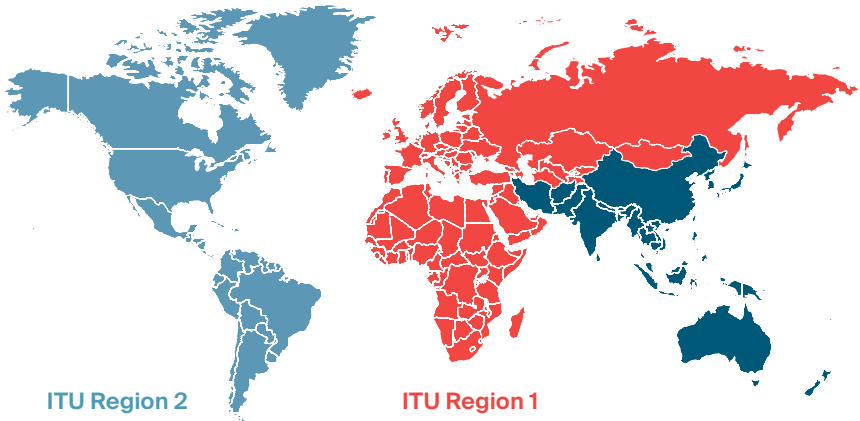

Choosing the right location

Your choice of installation locations for your Aria X2 transmitter(s) and Dyna Drum receiver(s) can have a significant effect on their range and speed of communication.

- Avoid installing either the Aria X2 transmitter or the Dyna Drum receiver unit(s) near to metallic objects.
- Maintain a clear 'line of sight' path between the Aria X2 transmitter and the Dyna Drum.

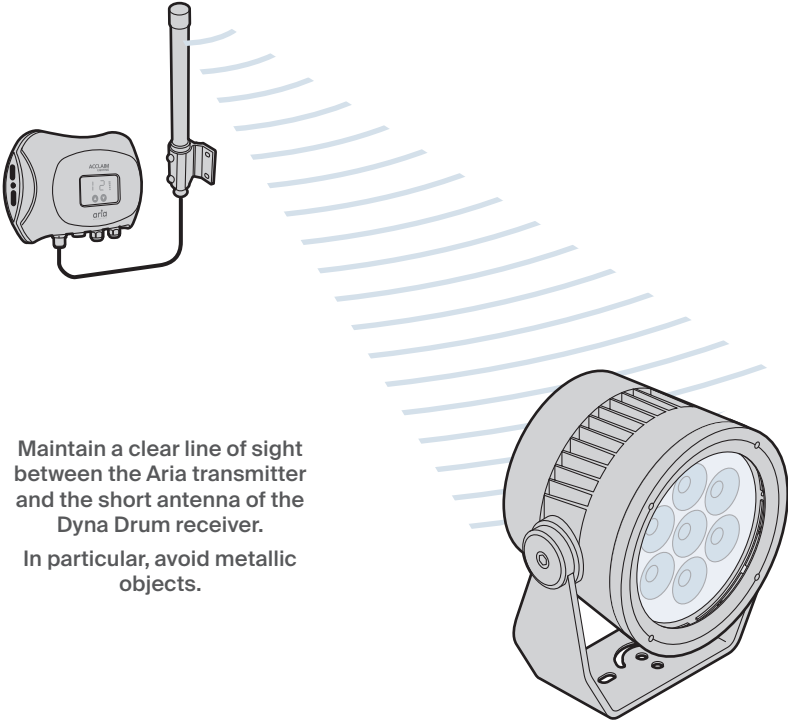

Maintain a clear line of sight between the Aria transmitter and the short antenna of the Dyna Drum receiver.

In particular, avoid metallic objects.

Interference created by objects

The composition of nearby objects can have a significant impact on the quality of the RF signal. Here are a few examples:

- Standard drywall does not present much of an issue to the 2.4GHz wireless spectrum. However, things inside or attached to the drywall, such as copper pipe, electrical conduit, and circuit breaker panels, will partially block RF signal propagation.
- Hollow cement block walls will dampen the RF signal.
- Reinforced concrete walls typically contain rebar that will contribute to significant RF signal strength loss.
- Large metal structures such as metal cabinets, HVAC units, machinery, brew kettles, etc. may partially or completely block the RF signal.

Dyna Drum specifications

Model type	White	SCS	Color
Native beam angle	5°	3° or 7°	8°
Lumen maintenance (L ₇₀)	130,000 hours	130,000 hours	130,000 hours
Housing	Die cast aluminum	Die cast aluminum	Die cast aluminum
Ingress protection	IP67 (wet location)	IP67 (wet location)	IP67 (wet location)
Impact protection	IK10 (20 joule impact)	IK10 (20 joule impact)	IK10 (20 joule impact)
Power input	100 - 277VAC 50/60Hz	100 - 277VAC 50/60Hz	100 - 277VAC 50/60Hz
Power consumption	60/110W	60/110W	60/110W
Operating temperature	-40°F to 122°F (-40°C to 50°C)	-40°F to 122°F (-40°C to 50°C)	-40°F to 122°F (-40°C to 50°C)
Weight	19 lbs (8.61 kg)	19 lbs (8.61 kg)	19 lbs (8.61 kg)

Certifications



Outdoor Linking System (OLS) specifications

AC conductors	3 x 14AWG
DMX conductors	4 x 20AWG plus shield
Maximum input voltage	305VAC
Surge voltage	1000V
Maximum total line current	15A
Maximum total line power	120VAC: 1,800W 230VAC: 3,450W 277VAC: 4,155W
Maximum run length	120VAC: 150' (45m) 230VAC: 300' (90m) 277VAC: 350' (106m)
Flame resistance	UL94-V0
IP rating	IP67, wet location
Operating temperature	-40°F to 176°F (-40°C to 80°C)

Dimensions

Dyna Drum S3

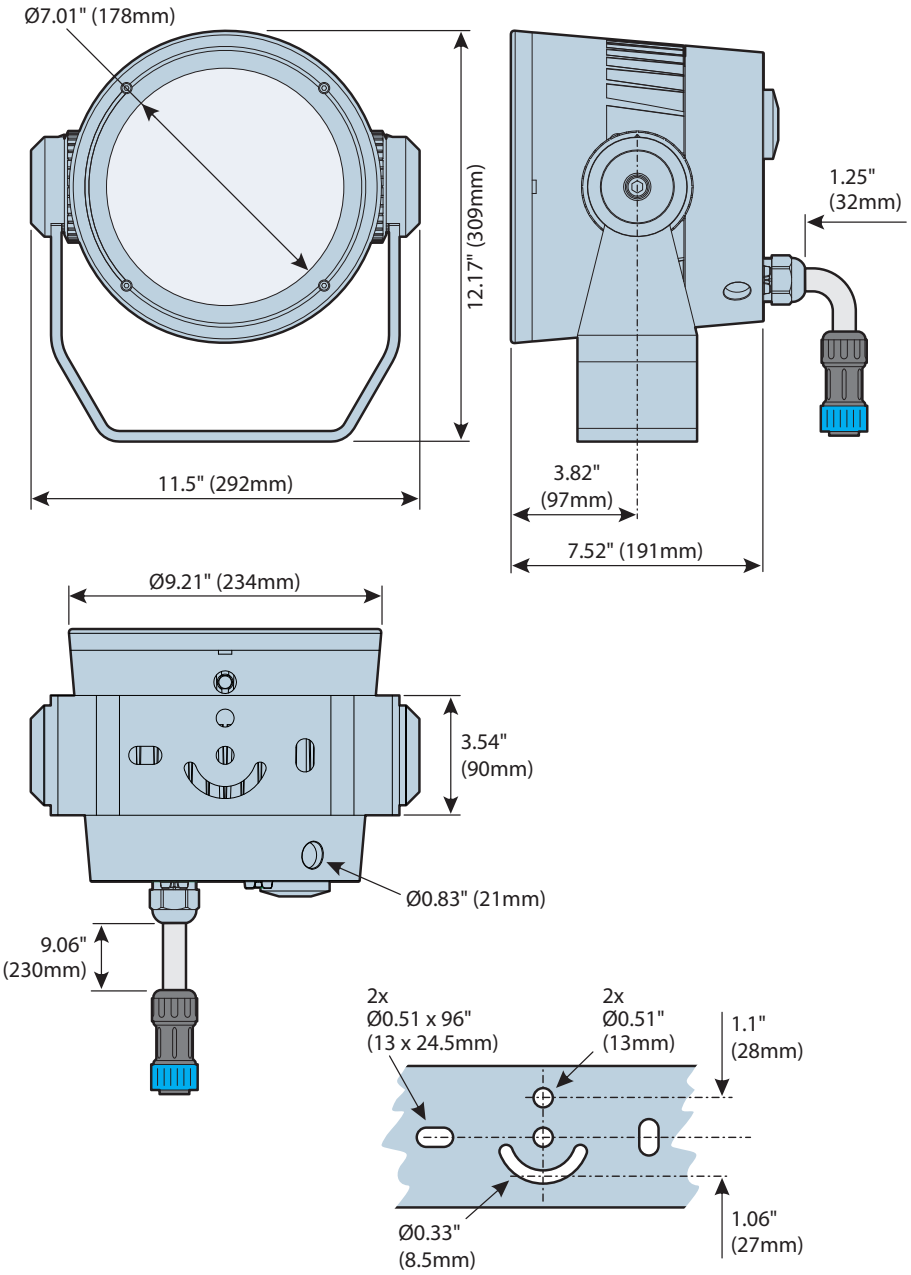

AJBOX1

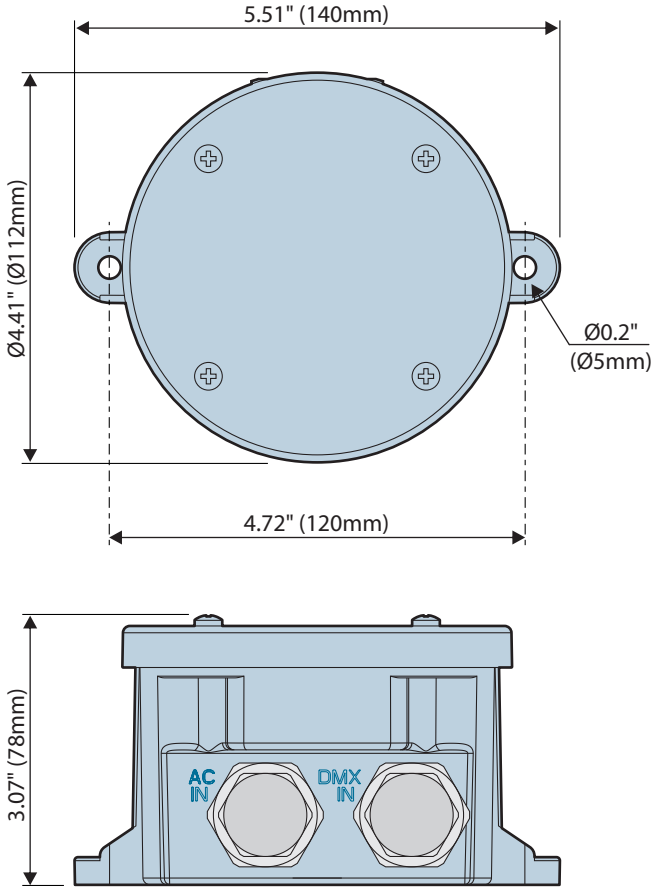

Weight: 1.05 lbs (474g)

Limited product warranty

A. Acclaim Lighting™ hereby warrants, to the original purchaser, Acclaim Lighting finished products to be free of manufacturing defects in material and workmanship for a standard period of:

- Fixtures: 5 Years (1,825 days) from the date of purchase.
- Drivers, power supplies and accessories: 5 Years (1,825 days) from the date of purchase.
- Flex Products: 3 Years (1,095 days) from the date of purchase.
- Controllers: 2 Years (730 days) from the date of purchase.

It is the owner's responsibility to establish the date and place of purchase and warranty terms by acceptable evidence, at the time service is sought.

B. For warranty service, send the product only to the Acclaim factory. All shipping charges must be pre-paid. If the requested repairs or service (including parts replacement) are within the terms of this warranty, Acclaim Lighting will pay return shipping charges only to a designated point within the United States. If the entire instrument is sent, it must be shipped in its original package. No accessories should be shipped with the product. If any accessories are shipped with the product, Acclaim Lighting shall have no liability whatsoever for loss of or damage to any such accessories, nor for the safe return thereof. Acclaim reserves the right to replace the item with same or similar product at its discretion.

C. This warranty is void if the serial number has been altered or removed; if the product is modified in any manner which Acclaim concludes, after inspection, affects the reliability of the product; if the product has been repaired or serviced by anyone other than the Acclaim Lighting factory unless prior written authorization was issued to purchaser by Acclaim Lighting; if the product is damaged because not properly maintained as set forth in the instruction manual.

D. This is not a service contract, and this warranty does not include maintenance, cleaning or periodic check-up nor do we guarantee as part of this warranty any lumen performance during period. Parts not covered by this warranty include: fuses, external power supplies, third party items not manufactured by Acclaim lighting. During the period specified above, Acclaim Lighting will replace defective parts at its expense, and will absorb all expenses for warranty service and repair labor by reason of defects in material or workmanship. The sole responsibility of Acclaim Lighting under this warranty shall be limited to the repair of the product, or replacement thereof, including parts, at the sole discretion of Acclaim Lighting. At no time will installation or re-installation or products labor or liability costs will be assumed by Acclaim Lighting. All products covered by this warranty were manufactured after January 1, 2012, and bear identifying serial number marks to that effect.

E. Acclaim Lighting reserves the right to make changes in design and/or improvements upon its products without any obligation to include these changes in any products theretofore manufactured. No warranty, whether expressed or implied, is given or made with respect to any accessory supplied with products describe above. Except to the extent prohibited by applicable law, all implied warranties made by Acclaim Lighting in connection with this product, including warranties of merchantability or fitness, are limited in duration to the warranty period set forth above. And no warranties, whether expressed or implied, including warranties of merchantability or fitness, shall apply to this product after said period has expired.

F. Marine or extreme weather location applications using Acclaim lighting products are subject to a 2 year limited warranty and Acclaim must be notified prior to delivery of units for such applications so that preventative treatment can be made to the products to ensure proper performance and product life with a special marine code coating / sealing process at an additional cost.

G. The consumer's and or dealer's sole remedy shall be such repair or replacement as is expressly provide above; and under no circumstances shall Acclaim Lighting be liable for any loss or damage, direct or consequential, arising out of the use of, or inability to use, this product. This warranty is the only written warranty applicable to Acclaim Lighting products and supersedes all prior warranties and written descriptions of warranty terms and conditions heretofore published.



TM