

PROJECT _____ FIRM _____ ORDER # _____ TYPE _____ QTY _____





The **Dyna Drum™** family of floodlights has been the premier choice of serious designers for years; their high outputs, robust weather protection and unmatched reliability are legendary.

Dyna Drum S3 White models use high-CRI single color emitters to deliver intense white light over long throws. The native 5° beam can be easily modified with quick-fit spread lenses to suit wider applications.

Dyna Drum fixtures are equally happy to receive DMX control via cable or the airwaves, thanks to the Aria™ X2 wireless receiver built into every unit. A clear daylight-readable OLED touch-screen display provides access to a comprehensive configuration menu system. Alternatively, key configuration changes can be made remotely using either RDM (Remote Device Management), or via BLE (Bluetooth™ Low Energy) wirelessly from our free iOS app.

Every Dyna Drum S3 is supplied with a bare wire power/control feed cable, which attaches directly to its OLS connector. The OLS connector also makes the Dyna Drum S3 instantly compatible with Acclaim's celebrated Outdoor Link System™ (see page 10); the rapid-fit cabling solution your installers will never want to be without.

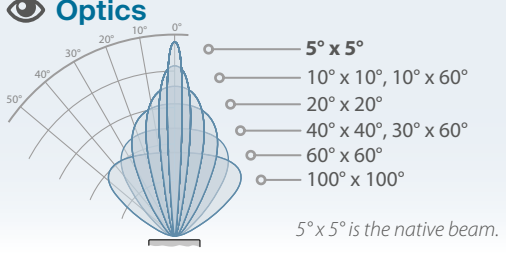
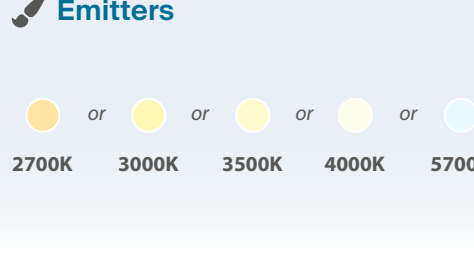
At a glance

 <p>Optics</p> <ul style="list-style-type: none"> 5° x 5° 10° x 10°, 10° x 60° 20° x 20° 40° x 40°, 30° x 60° 60° x 60° 100° x 100° <p>5° x 5° is the native beam.</p>	 <p>Emitters</p> <p>2700K or 3000K or 3500K or 4000K or 5700K</p>	 <p>CoreSwap technology (see page 13)</p>		
<p>Power</p> <p>100 to 277VAC 50/60Hz</p>	<p>Temperature</p> <p>-40° F to 122° F -40° C to 50° C</p>	<p>Protection</p> <p>Ingress: IP67 Impact: IK10 Vibration: 3G</p>	<p>Output</p> <p>Up to 9,455 lumens</p>	<p>Core technologies</p> <p>OutdoorLink system ColorDrive technology AcclaimModular systems aria MULTI-BEAM WIRELESS CONTROL</p>

Configure your product

DS3W

-DS3E

-DS3O

-DS3P

Example final code: **DS3W1-DS3EE-DS3OK-DS3PH**

Finish color:
1 = Black (RAL 9005)
2 = White (RAL 9003)
4 = Gray (RAL 7047)
7 = Custom* (RAL #)

Emitters:
D = 2700K
E = 3000K
F = 3500K
G = 4000K
J = 5700K





Optics:
B = 5° x 5° (native)
C = 10° x 10°
D = 20° x 20°
H = 40° x 40°
K = 60° x 60°
M = 100° x 100°
Q = 30° x 60°
R = 10° x 60°

Output mode:
H = High Output
S = Standard Output

* indicates special order items, which may require longer lead times



Specifications

Emitters	2700K, 3000K, 3500K, 4000K, 5700K
Optics	5° native, 10° x 10°, 10° x 60°, 20° x 20°, 40° x 40°, 60° x 60°, 30° x 60° or 100° x 100°
Output	Up to 9,455 lumens
Lumen maintenance	L ₇₀ 130,000 hours (@ 25° C)
Control	0-100% dimming via wired DMX (with RDM configuration) plus built-in Aria™ X2 Wireless System
Maximum fixtures in series	32 via wired DMX. Power local to each fixture or use Acclaim's Outdoor Link System - see page 10
Operating voltage	100-277VAC, 50/60 Hz
Power consumption	110W (High Output model), 60W (Standard Output model)
Connection	Removable power and control cord (9 feet, 2.7m with bare wire tails) or use Outdoor Link System
Mounting	Surface mount yoke included. Tenon mount, pipe clamp and extender bar options available
Effective projected area	1.16 ft ²
Material	Die cast aluminum with glass lens, marine and natatorium environment ready
Finish colors	Gray (RAL 7047), black (RAL 9005), white (RAL 9003) or custom colors (provide RAL #)
Ambient temperature range	-40° F to 122° F (-40° C to 50° C)
Ingress protection	IP67, wet location (temporary submersion up to 1m for 30 minutes)
Impact protection	IK10, protection against 20 joule impact (40cm distance).
Vibration protection	ANSI C136.31, 3G-rated for high vibration and bridge applications
Surge protection	Built-in 10kV, 5kA I _n , 10kA I _{max} protection
Warranty	5 years, limited
Weight	19 lbs (8.61 kg)
Dimensions	See page 8
Certifications	    

Photometrics

For all available IES files, please visit acclaimlighting.com/products/dyna-drum-s3-white

Optics	4000K lumens	Efficacy (lm/w)	Center Candela
5° x 5° (native)	9,455	102	367,680
10° x 10°	7,782	83	112,137
20° x 20°	7,752	83	36,979
40° x 40°	7,535	81	12,706
60° x 60°	7,316	78	7,265
100° x 100°	7,099	76	2,795
10° x 60°			
30° x 60°			

To calculate lumen outputs for other emitter types

The table above shows the photometric test results for a Dyna Drum S3 fixture fitted with 4000K emitters in combination with each of the various optic options. To calculate the lumen output for any other emitter type, take the **4000K lumens** value for the required optic and multiply it by one of the following:

- 2700K 0.768
- 3000K 0.873
- 3500K 0.955
- 5700K 1.053

Welcome to the Dyna Drum family...

... where consistent emitter and optic options across the E3, S3 and H3 sizes allow you to precisely mix and match fixtures within any installation.

White

High CRI, high output white emitters in a range of color temperatures.



E3

YOU ARE HERE



S3



H3

Output	Up to 3,900 lumens	Up to 9,455 lumens	Up to 27,344 lumens
Emitters	2700K to 5700K, high CRI - consistent across the range		
Optics	5° to 100° beam angles - consistent across the range		

Color

Quad RGBW emitters with a choice of white color temperatures to provide superior color mixing.



E3



S3



H3

Output	Up to 2,219 lumens	Up to 4,730 lumens	Up to 13,498 lumens
Emitters	SpectrumFour QS, QW4 or QW6 - consistent across the range		
Optics	8° to 100° beam angles - consistent across the range		

SCS

Individual emitters producing the narrowest beam angles for maximum punch in long-throw applications.



E3



S3



H3

Output	Up to 2,750 lumens	Up to 5,650 lumens	Up to 17,325 lumens
Emitters	RGBW, RGBA, RGBAL or DW - consistent across the range		
Optics	3° to 100° beam angles - consistent across the range		

Related components

Beam accessories

Half snoots

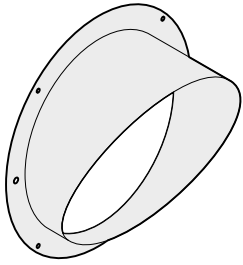

Gray
 Black
 White
 Custom*

DS3HSG
DS3HSB
DS3HSW
DS3HSC

Full snoots

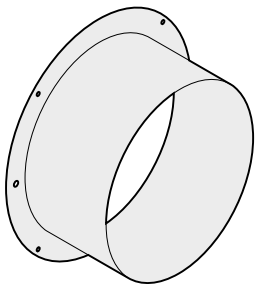

Gray
 Black
 White
 Custom*

DS3FSG
DS3FSB
DS3FSW
DS3FSC

Wide snoots

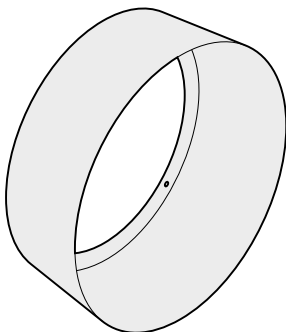

Gray
 Black
 White
 Custom*

DS3WSG
DS3WSB
DS3WSW
DH3WSC

Barn doors

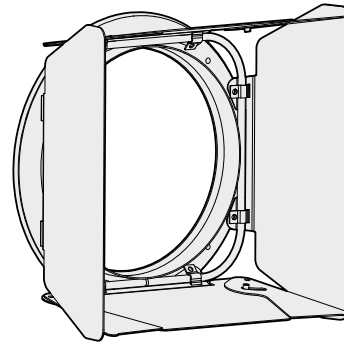

Gray
 Black
 White
 Custom*

DS3BDAG
DS3BDAB
DS3BDAW
DS3BDAC

Spread lenses

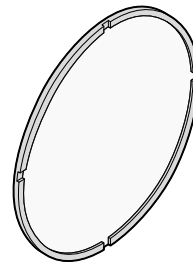

10° beam
 20° beam
 40° beam
 60° beam
 100° beam
 30° x 60° beam
 10° x 60° beam

DS3OC
DS3OD
DS3OH
DS3OK
DS3OM
DS3OQ
DS3OR

Wire guards

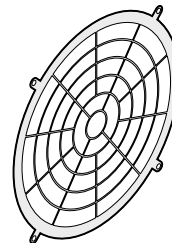

Gray
 Black
 White
 Custom*

DS3WGG
DS3WGB
DS3WGW
DS3WGC

*RAL # also required

PROJECT _____ FIRM _____ ORDER # _____ TYPE _____ QTY _____

Related components

Mounting accessories

Tenon mounts

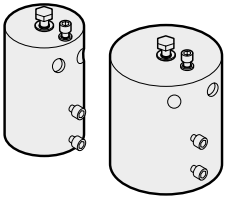

- | | |
|--|----------------|
| 2" schedule 40 (2.51", 56mm inner dia.) | TM2 S40 |
| 2" nominal (2", 51mm inner dia.) | TM2 NOM |
| 3.5" schedule 40 (4.13", 105mm inner dia.) | TM4 S40 |
| 4" nominal (4", 102mm inner dia.) | TM4 NOM |

Pipe clamps

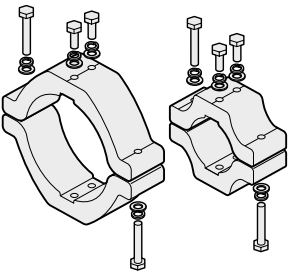

- | | |
|----------------|----------------|
| 2" schedule 40 | PC2 S40 |
| 2" nominal | PC2 NOM |
| 4" schedule 40 | PC4 S40 |
| 4" nominal | PC4 NOM |

Junction boxes

AJBOX1 (IP66) junction box (plus outlet cable gland)

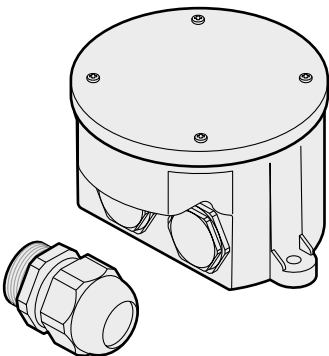

Part # **AJBOX1**
 IP66 NEC compliant high and low voltage junction box with two sealed 1/2" input ports for AC & DMX plus NPT 3/4" output port for OLSF# feed cable. Built-in AC surge protection up to 10kV and 10kA

Extender arms

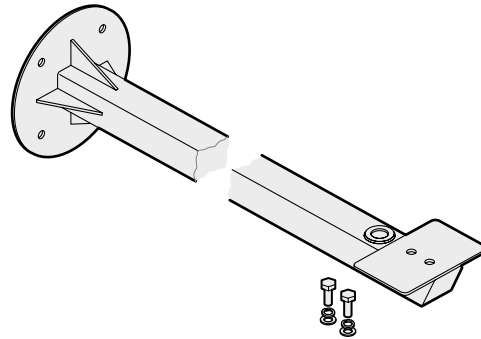

Fixture bolts and washers plus cable access seal included

	1'	2'	3'
Gray	OFLEB1G	OFLEB2G	OFLEB3G
Black	OFLEB1B	OFLEB2B	OFLEB3B
White	OFLEB1W	OFLEB2W	OFLEB3W
Custom*	OFLEB1C	OFLEB2C	OFLEB3C

*RAL # also required

AJBOX1 Extended (IP66) junction box

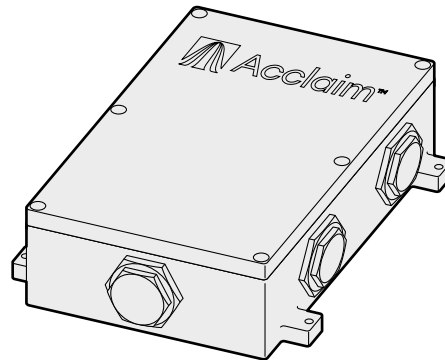

Part # **AJBOX1E#** (# = color)
 IP66 NEC-compliant high and low voltage junction box with six sealed NPT 3/4" access ports for conduit fixtures or cable glands (by others) for power and control plus OLSF# feed cable. Built-in AC surge protection up to 10kV and 10kA

PROJECT	FIRM	ORDER #	TYPE	QTY
---------	------	---------	------	-----

Related components

Outdoor Linking System - See also pages 9, 10 and 11

Feed cables

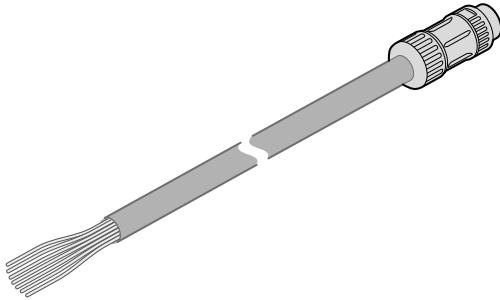

- 1' (30cm) **OLSF1#-V2**
- 5' (1.5m) **OLSF5#-V2**
- 10' (3m) **OLSF10#-V2**
- 25' (7.6m) **OLSF25#-V2**
- 50' (15.2m) **OLSF50#-V2**

= color: G-Gray, B-Black, W-White, C-Custom (RAL# required)

Link cables

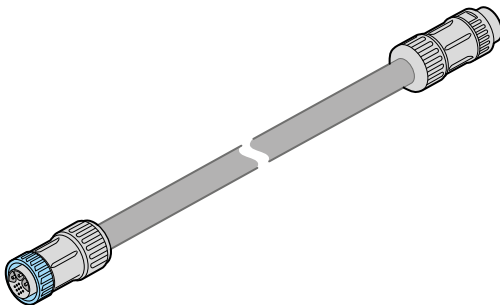

- 1' (30cm) **OLSL1#-V2**
- 5' (1.5m) **OLSL5#-V2**
- 10' (3m) **OLSL10#-V2**
- 25' (7.6m) **OLSL25#-V2**
- 50' (15.2m) **OLSL50#-V2**

= color: G-Gray, B-Black, W-White, C-Custom (RAL# required)

End cap with DMX termination

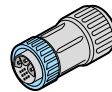

- | | | |
|-------|----------------------------------|----------------|
| Part# | OLSEC-B
OLSEC-W | Black
White |
|-------|----------------------------------|----------------|

T-junction

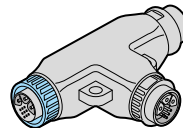

- | | | |
|-------|----------------------------------|----------------|
| Part# | OLST2-B
OLST2-W | Black
White |
|-------|----------------------------------|----------------|

Y-junction

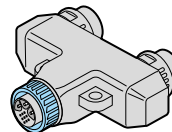

- | | | |
|-------|----------------------------------|----------------|
| Part# | OLSY2-B
OLSY2-W | Black
White |
|-------|----------------------------------|----------------|



PROJECT	FIRM	ORDER #	TYPE	QTY
---------	------	---------	------	-----

Related components

Signal converters (see page 12)

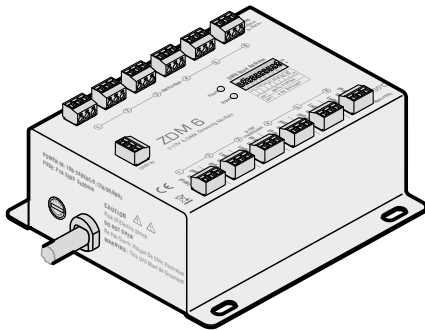

Multi-channel (0-10V) converter

ZDM6

Test and configuration tool kit

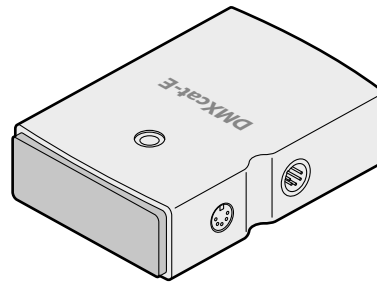

DMXcat-E

DMX/RDM, ArtNet, sACN, SMPTE LTC and Midi test/configuration tool

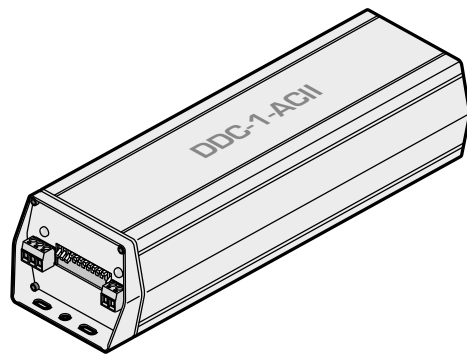

DALI multiple channel converter

DDC1AC

Wireless DMX transceiver

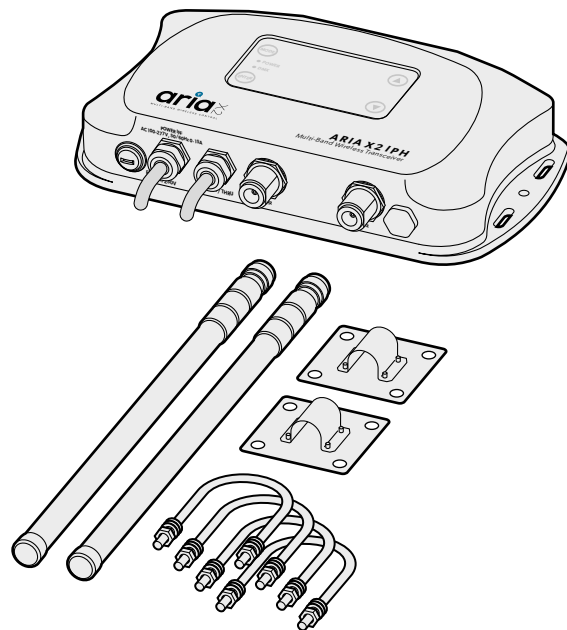

Aria X2 IPH multi-band wireless transceiver with two antennas, two antenna wall brackets and four U-bolts

AX2165



PROJECT _____ FIRM _____ ORDER # _____ TYPE _____ QTY _____

Dimensions

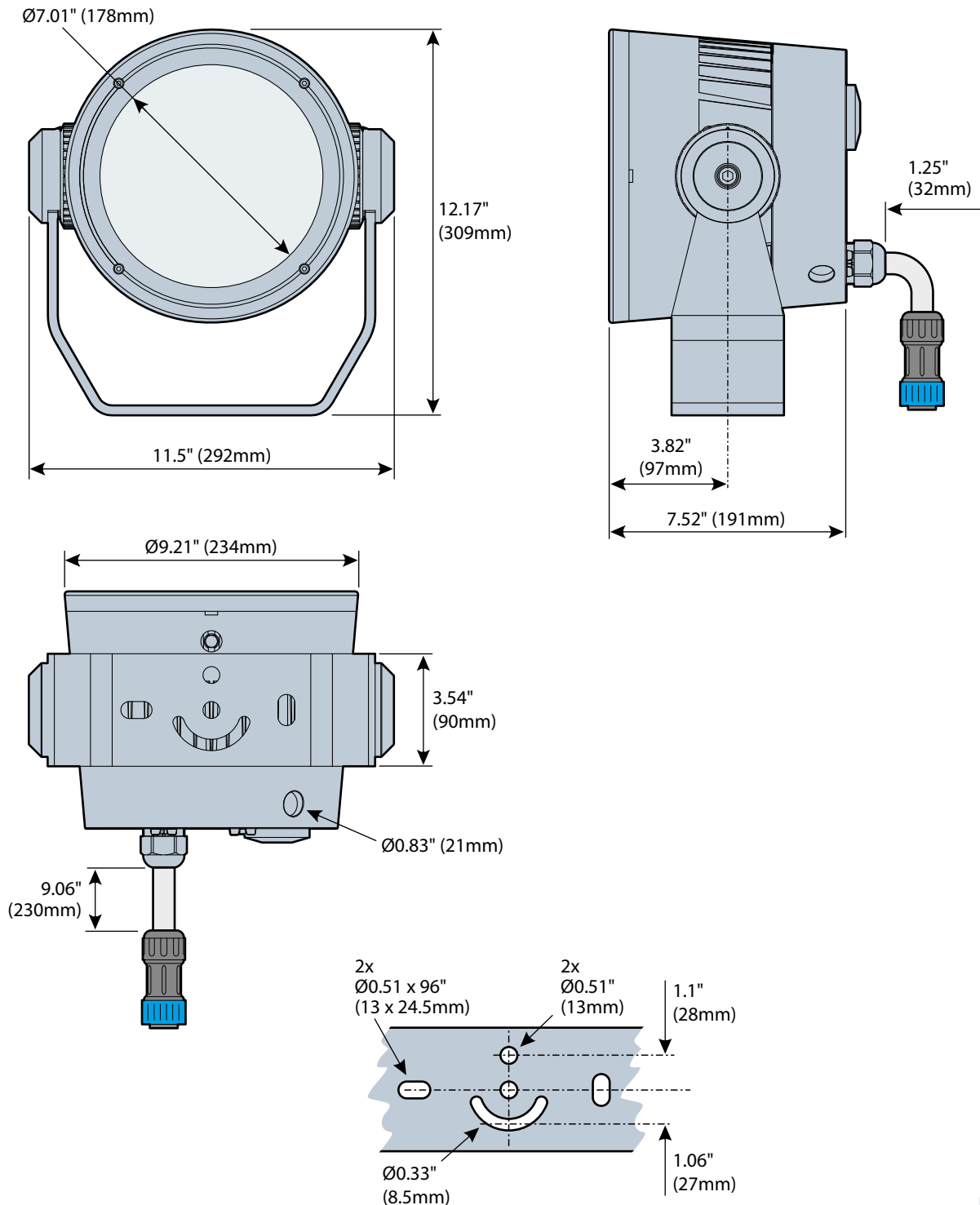

PROJECT _____ FIRM _____ ORDER # _____ TYPE _____ QTY _____

Dimensions - OLS items

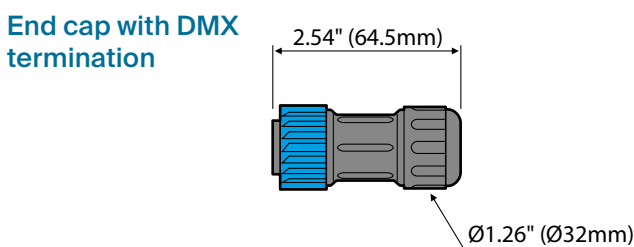
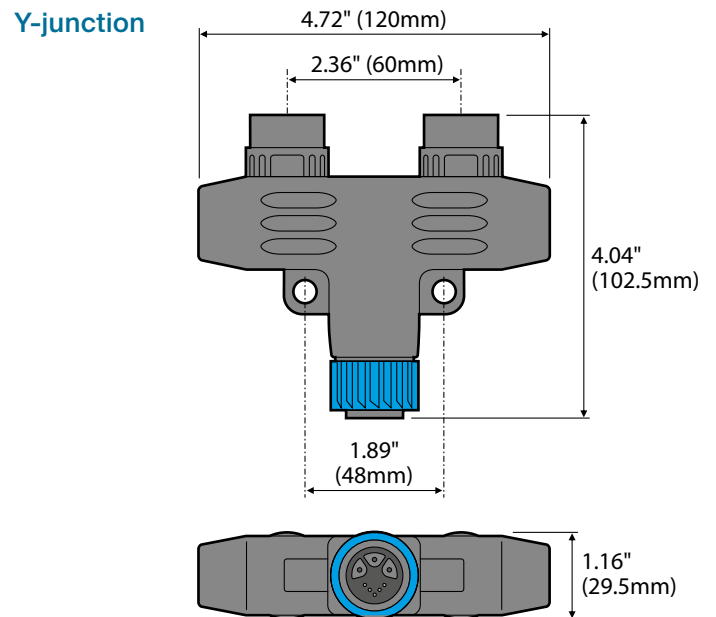
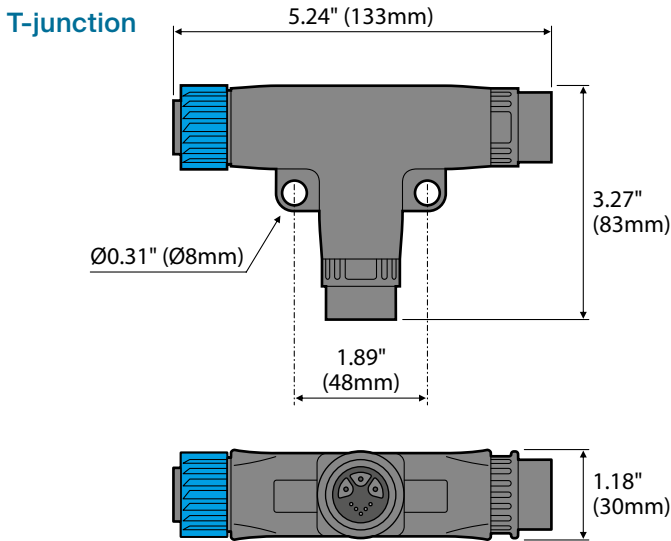
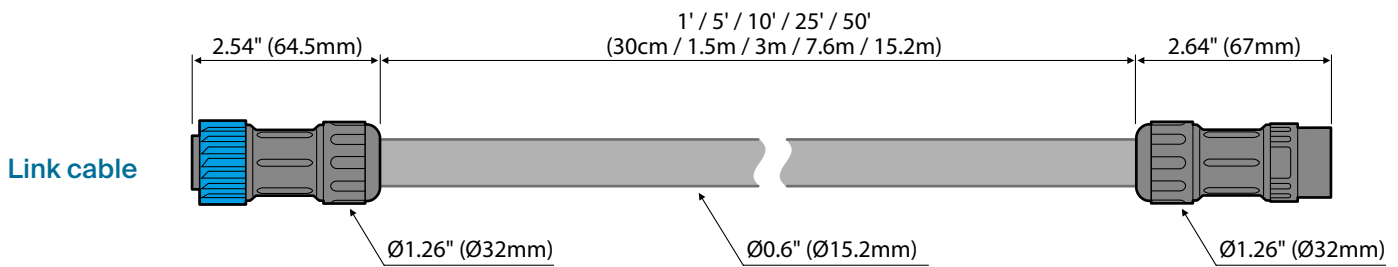
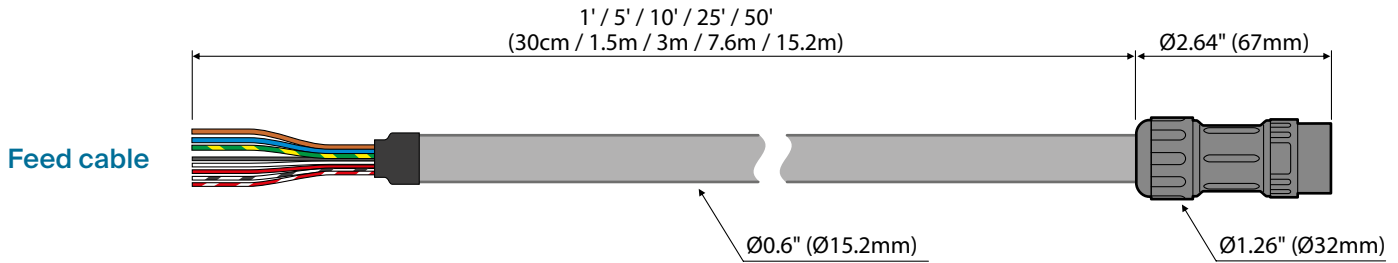

PROJECT _____ FIRM _____ ORDER # _____ TYPE _____ QTY _____

Typical OLS configuration

The Dyna Drum S3 connector is directly compatible with the Outdoor Link System, which greatly simplifies the task of distributing power and control to multiple fixtures:

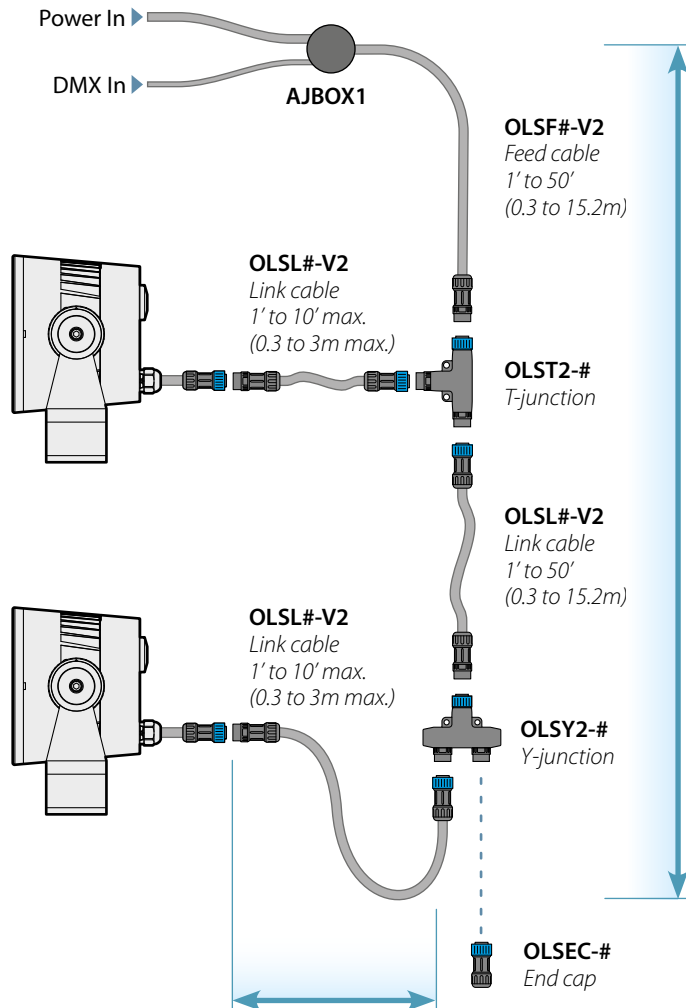

- The total length from a T-junction to a fixture must not exceed 10' (3m) in length.
- A terminator must be fitted to the final T-junction to simultaneously protect the live connections and correctly terminate the DMX control feed.
- Maximum fixtures and cable lengths in a single OLS run:
 120VAC: 30x **SO** or 16x **HO** / 150'
 230VAC: 32x **SO** or 30x **HO** / 300'
 277VAC: 32x **SO** or 32x **HO** / 350'

Power and control wiring

Dyna Drum S3 models are supplied with a combined power and control cord (roughly 9 feet, 2.7m in length and with bare wire tails).

The color designations for the supplied feed in cable are as follows:

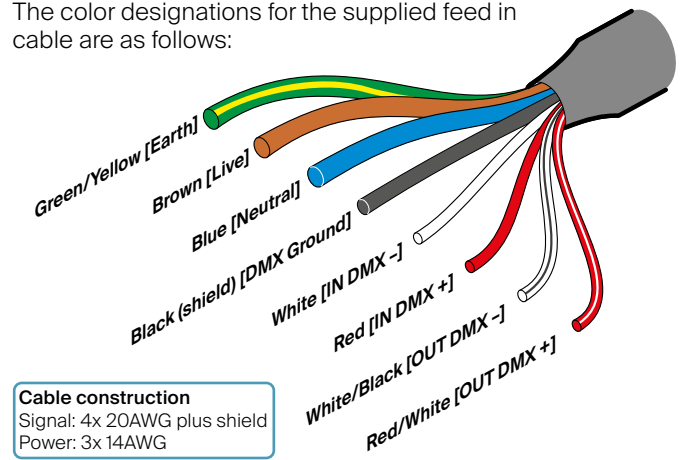

Power

The fixture power requirements are as follows:

- Voltage: 100-277VAC 50/60Hz
- Power: **110W** (High Output model), **60W** (Standard Output model)

Note: Acclaim recommends taking proper precautions for external surge protection, as control and power electronics can be damaged by major events. Ensure that the mains power is supplied from a suitably protected source and initial connections are made within IP rated enclosures. Acclaim recommends Belden 9842 or approved equivalent for all DMX wiring applications.

Note: The Acclaim AJBOX1 includes internal surge protection circuitry.

Control wiring

DMX cable recommendations:

- Indoor exposed or in conduit above grade: *Belden 9842*
- Indoor plenum: *Belden 82842*
- Outdoor exposed, direct burial, or inside conduit below grade: *Belden 3107DB*

Alternatives must meet **all** of the following requirements:

- Construction**: Shielded, twisted pair (or multi-pair).
- Impedance**: Between 90 and 120Ω.
- Capacitance**: 15pF or less.



PROJECT	FIRM	ORDER #	TYPE	QTY
---------	------	---------	------	-----

OLS connectors



The Outdoor Link System uses matching IP67-rated connectors throughout, each of which combines AC power and DMX control. A simple color code is used:

- Connectors with blue collars are inputs,
- Connectors with black collars (white option available) are outputs.

The blue collars form the locking and release mechanism ➔

To make a link

Simply align a black and a blue connector and push them together with a click.

To break a link

Twist and hold the blue collar while you withdraw the black connector.

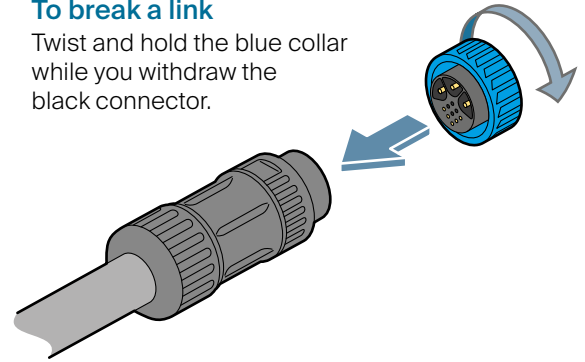

OLS Junctions

Two types of OLS junctions are available: T-junctions and Y-junctions. Electrically they are identical, they both split one input into two power/control outputs.

Y-junction

Most useful when the next fixtures are located in the same direction from the junction.

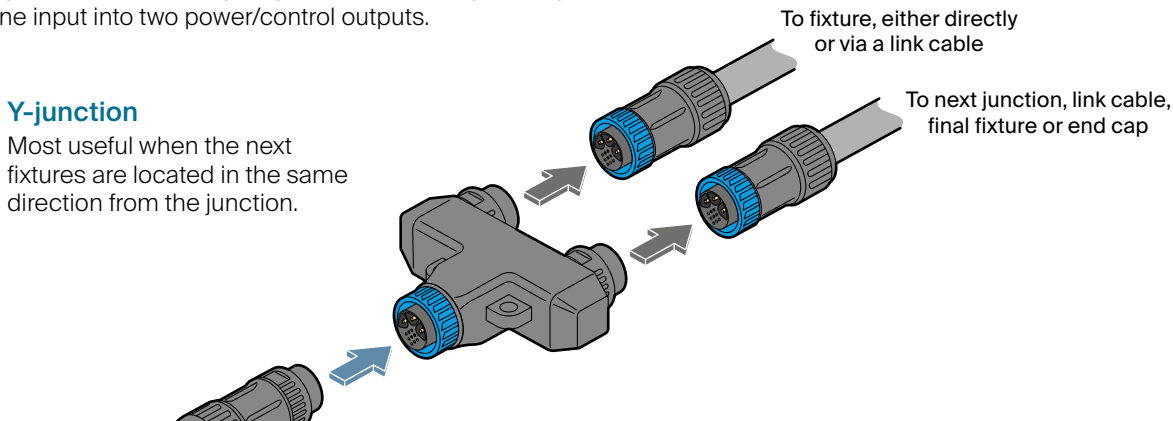

T-junction

Most useful when the next fixtures are located in different directions from the junction.

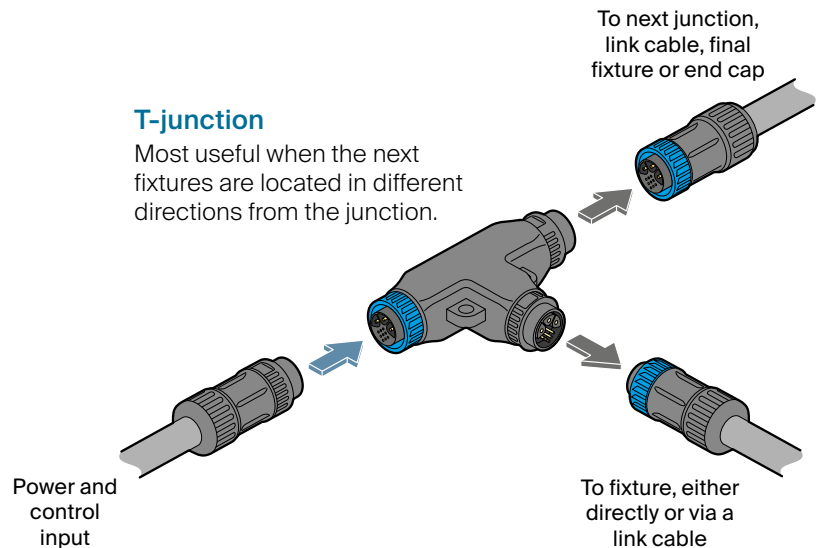

PROJECT	FIRM	ORDER #	TYPE	QTY
---------	------	---------	------	-----

Alternative control inputs

Dyna Drum S3 fixtures use DMX as their native control method, however, it is possible to use other common control protocols when required, such as 0-10V (source or sink) or DALI.

Control inputs via converters

- DMX - connect a DMX input directly to the feed cable.
- 0-10V - use an Acclaim Lighting ZDM 6 to convert one or more analog control feeds into a combined DMX feed.
- DALI - use an Acclaim Lighting DDC-1-AC to convert one or more DALI channels into a combined DMX feed.

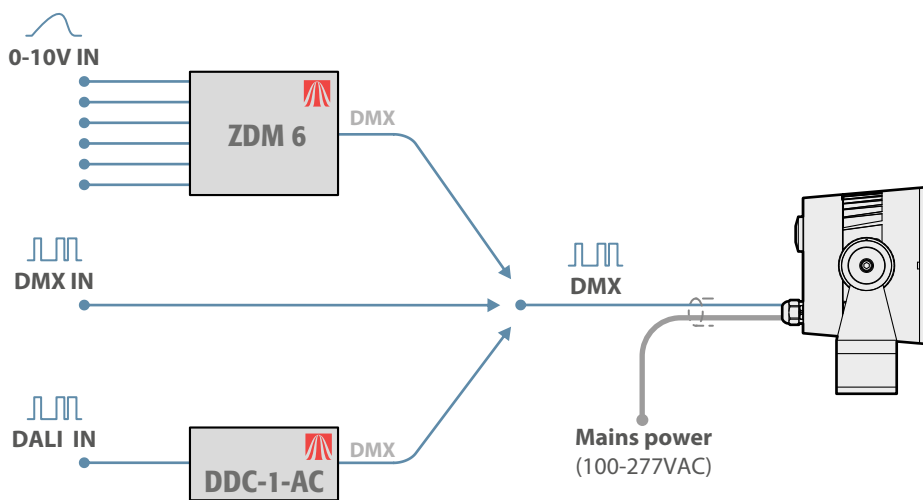

When using Acclaim Lighting ZDM 6 or DDC-1-AC modules it is possible to convert multiple inputs into separate DMX channels within a consolidated feed. The ZDM 6 can convert up to six 0-10V inputs into DMX channels, whereas the DDC-1-AC can convert a maximum of 64 DALI channels (although large numbers of channels are not recommended due to the timing limitations of the DALI standard).

Wireless DMX control

Each Dyna Drum S3 fixture contains an Aria X2 wireless DMX receiver as standard, which can greatly simplify the deployment of multiple fixtures in spaces that contain no control wiring infrastructure. A single Aria transmitter can control unlimited Dyna Drum S3 fixtures, at distances up to 2,000 feet (609m).

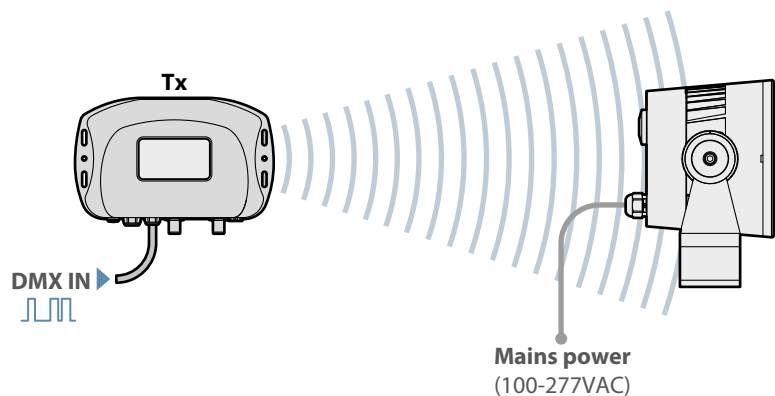

PROJECT	FIRM	ORDER #	TYPE	QTY
---------	------	---------	------	-----

Modular flexibility

Like all Acclaim Lighting products, Dyna Drum S3 fixtures are designed and built for the long haul in professional environments. In the unlikely event of failure during the lifetime of a fixture, it is reassuring to know that a solution is ready to return to 100% operation in the shortest possible downtime. Our **CoreSwap Technology** ensures that only the affected module need ever be swapped out, whether that be in our service center or at your on-site installation.

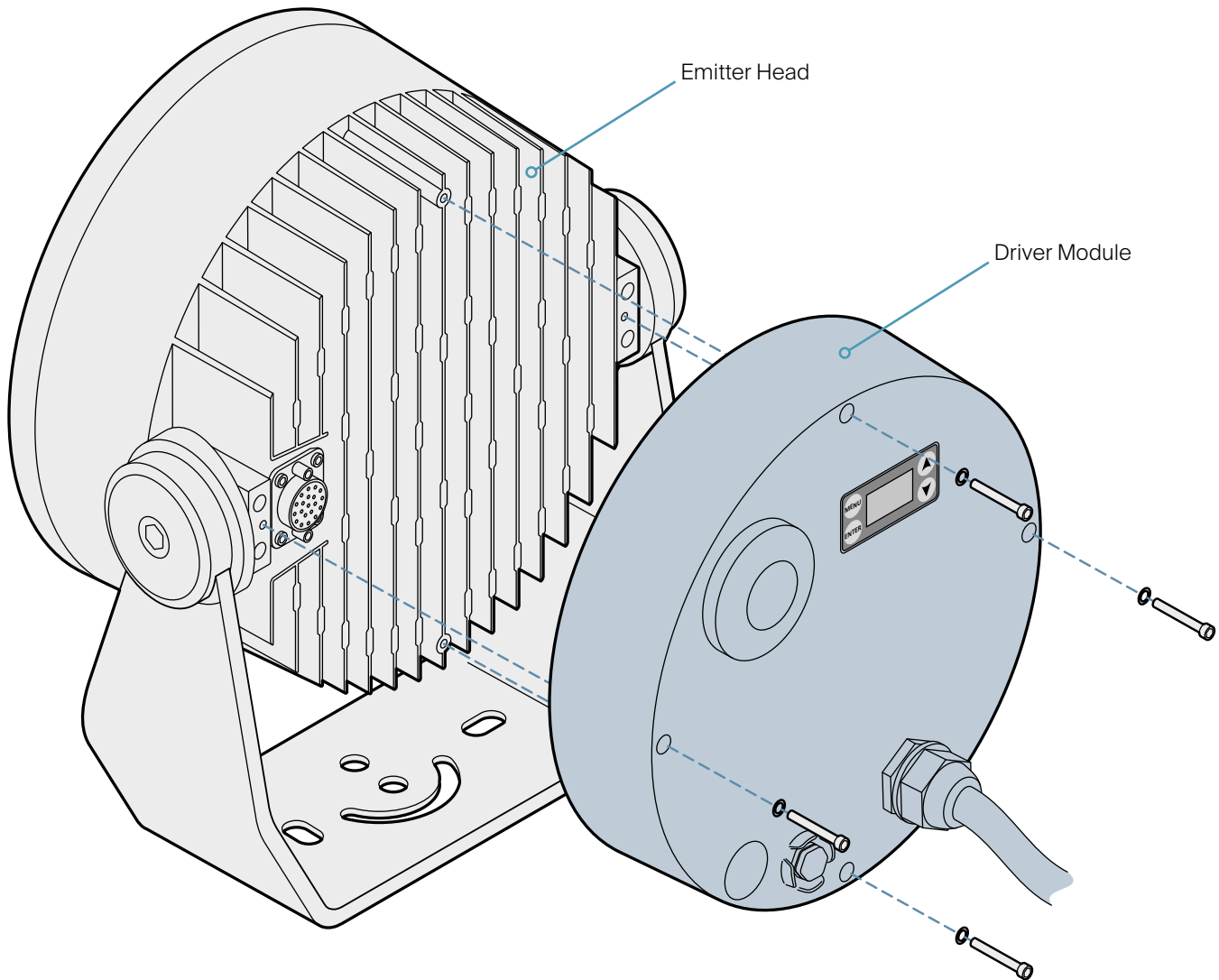

For full installation details, please refer to the **user guide**, available for free download here:

