

PROJECT _____ FIRM _____ ORDER # _____ TYPE _____ QTY _____



The **Dyna Drum™** family of floodlights has been the premier choice of serious designers for years; their high outputs, robust weather protection and unmatched reliability are legendary.

Dyna Drum E3 SCS models use RGB+ or Dynamic White (DW) emitters to produce strong outputs and superior color mixing. The native 3° or 7° beam can be easily modified with quick-fit spread lenses to suit wider applications.

Dyna Drum fixtures are equally happy to receive DMX control via cable or the airwaves, thanks to the Aria™ X2 wireless receiver built into every unit. A clear daylight-readable OLED touch-screen display provides access to a comprehensive configuration menu system. Alternatively, key configuration changes can be made remotely using either RDM (Remote Device Management), or via BLE (Bluetooth™ Low Energy) wirelessly from our free iOS app.

Every Dyna Drum E3 is supplied with a bare wire power/control feed cable, which attaches directly to its OLS connector. The OLS connector also makes the Dyna Drum E3 instantly compatible with Acclaim's celebrated Outdoor Link System™ (see page 11); the rapid-fit cabling solution your installers will never want to be without.

At a glance

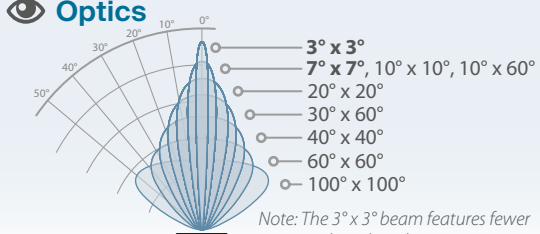
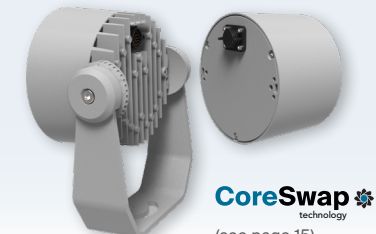
<h3>Optics</h3>  <p>Note: The 3° x 3° beam features fewer emitters than the other options.</p>	<h3>Emitters</h3> <ul style="list-style-type: none"> RGBW (W=3000K or W=4000K) or Dynamic White (DW) (2400K to 5500K) or RGBA or RGBAL plus (see page 13) 1800K CCT Select to 6000K 	 <p>CoreSwap technology (see page 15)</p>	
<h3>Power</h3> <p>100 to 277VAC 50/60Hz</p>	<h3>Temperature</h3> <p>-40° F to 131° F -40° C to 55° C</p>	<h3>Output</h3> <p>Up to 2,750 lm</p>	<h3>Core technologies</h3> <p>OutdoorLink system ColorDrive technology AcclaimModular systems aria</p>

Configure your product

DE3S

-DE3E

-DE3O

-DE3PS

Example final code:
DE3SY1-DE3EE-DE3OK-DE3PS

Mount type:
S = 1" NPS stem mount
Y = Yoke mount

Finish color:
1 = Black (RAL 9005)
2 = White (RAL 9003)
4 = Gray (RAL 7047)
7 = Custom* (RAL #)

Emitters:
T = RGBA
U = RGBW (W=3000K)
V = RGBW (W=4000K)
X = DW (2400K-5500K)
Y = RGBAL with CCT Select





Optics:
A = 3° x 3° (native)
E = 7° x 7° (native)
C = 10° x 10°
D = 20° x 20°
H = 40° x 40°
K = 60° x 60°
M = 100° x 100°
R = 30° x 60°
Q = 10° x 60°

* indicates special order items, which may require longer lead times



PROJECT	FIRM	ORDER #	TYPE	QTY
---------	------	---------	------	-----

Specifications

Emitters	RGBW (W=3000K or 4000K), RGBA, Dynamic White (2400K to 5500K) or RGBAL (+ CCT Select)
Optics	3° x 3°, 7° x 7°, 10° x 10°, 20° x 20°, 40° x 40°, 60° x 60°, 100° x 100°, 10° x 60° or 30° x 60°
Output	Up to 2,750 lumens
Lumen maintenance	L ₇₀ 130,000 hours (@ 25° C)
Control	0-100% dimming via wired DMX (with RDM configuration) plus built-in Aria™ X2 Wireless System
Maximum fixtures in series	32 via wired DMX. Power local to each fixture or use Acclaim's Outdoor Link System - see page 11
Operating voltage	100-277VAC, 50/60 Hz
Power consumption	50W
Connection	Stem Mount: Attached power and control cord (5 feet, 1.5m with bare wire tails) Yoke Mount: Removable power and control cord (5 feet, 1.5m) - OLS compatible (see page 11)
Mounting	Surface mount yoke or 1" NPS stem mount included, optional tenon mount or pole clamp
Effective projected area	1.01 ft ²
Material	Die cast aluminum with glass lens, marine and natatorium environment ready
Finish colors	Gray (RAL 7047), black (RAL 9005), white (RAL 9003) or custom colors (provide RAL #)
Ambient temperature range	-40° F to 131° F (-40° C to 55° C)
Ingress protection	IP67, wet location (temporary submersion up to 1m for 30 minutes)
Impact protection	IK10, protection against 20 joule impact (40cm distance).
Vibration protection	ANSI C136.31, 3G-rated for high vibration and bridge applications
Surge protection	Built-in 10kV, 5kA I _n , 10kA I _{max} protection
Warranty	5 years, limited
Weight	9 lbs (4.08 kg)
Dimensions	See page 8
Certifications	    

PROJECT	FIRM	ORDER #	TYPE	QTY
---------	------	---------	------	-----

Related components

Beam accessories

Half snoots

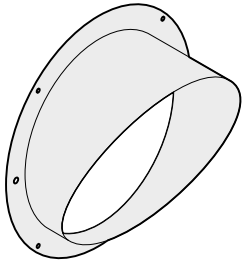

Gray	DE3HSG
Black	DE3HSB
White	DE3HSW
Custom*	DE3HSC

Wide snoots

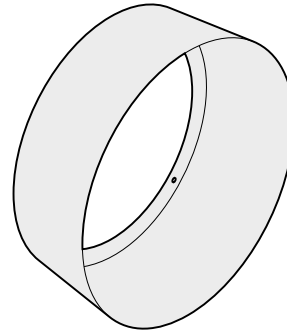

Gray	DE3WSG
Black	DE3WSB
White	DE3WSW
Custom*	DE3WSC

Full snoots

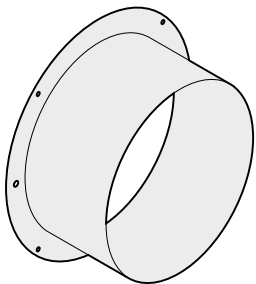

Gray	DE3FSG
Black	DE3FSB
White	DE3FSW
Custom*	DE3FSC

Spread lenses

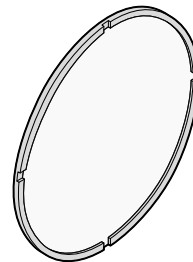

20° beam	DE3OD
40° beam	DE3OH
60° beam	DE3OK
100° beam	DE3OM
30° x 60° beam	DE3OQ
10° x 60° beam	DE3OR

*RAL # also required



PROJECT _____ FIRM _____ ORDER # _____ TYPE _____ QTY _____

Related components

Mounting accessories

Tenon mounts

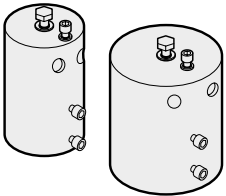

- | | |
|--|----------------|
| 2" schedule 40 (2.51", 56mm inner dia.) | TM2 S40 |
| 2" nominal (2", 51mm inner dia.) | TM2 NOM |
| 3.5" schedule 40 (4.13", 105mm inner dia.) | TM4 S40 |
| 4" nominal (4", 102mm inner dia.) | TM4 NOM |

Pipe clamps

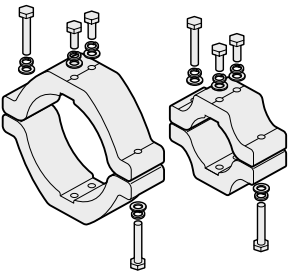

- | | |
|----------------|----------------|
| 2" schedule 40 | PC2 S40 |
| 2" nominal | PC2 NOM |
| 4" schedule 40 | PC4 S40 |
| 4" nominal | PC4 NOM |

Junction boxes

AJBOX1 (IP66) junction box (plus outlet cable gland)

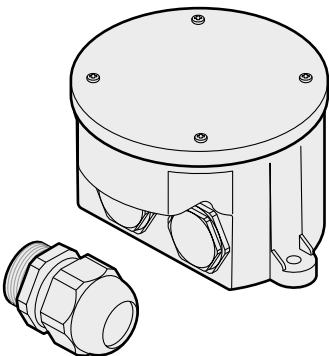

Part # **AJBOX1**
 IP66 NEC compliant high and low voltage junction box with two sealed 1/2" input ports for AC & DMX plus NPT 3/4" output port for OLSF# feed cable. Built-in AC surge protection up to 10kV and 10kA

Extender arms

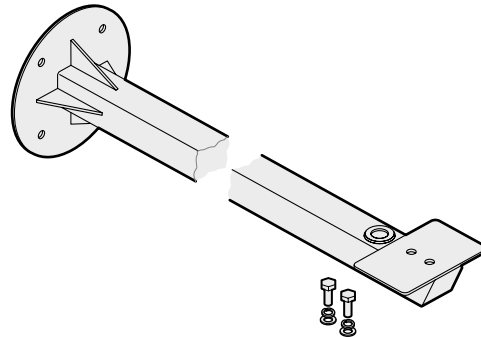

Fixture bolts and washers plus cable access seal included

	1'	2'	3'
Gray	OFLEB1G	OFLEB2G	OFLEB3G
Black	OFLEB1B	OFLEB2B	OFLEB3B
White	OFLEB1W	OFLEB2W	OFLEB3W
Custom*	OFLEB1C	OFLEB2C	OFLEB3C

*RAL # also required

AJBOX1 Extended (IP66) junction box

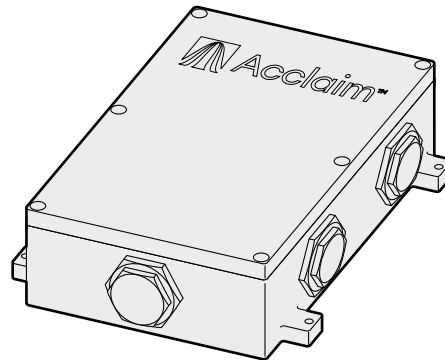

Part # **AJBOX1E#** (# = color)
 IP66 NEC-compliant high and low voltage junction box with six sealed NPT 3/4" access ports for conduit fixtures or cable glands (by others) for power and control plus OLSF# feed cable. Built-in AC surge protection up to 10kV and 10kA

PROJECT	FIRM	ORDER #	TYPE	QTY
---------	------	---------	------	-----

Related components

Mounting accessories

4" round box mount

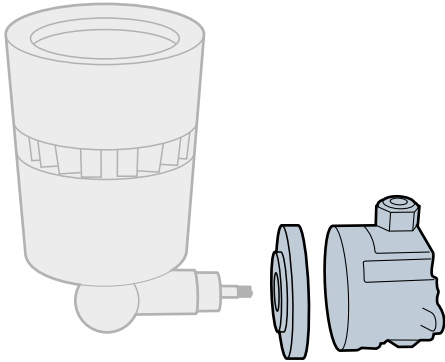

For use with Dyna Drum E3 stem mount variant

DE3EMB#

Surface mount

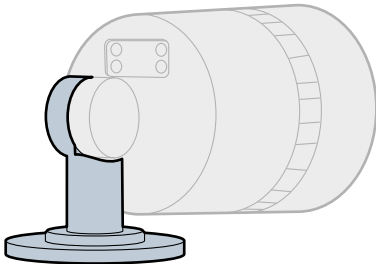

For use with Dyna Drum E3 stem mount variant

DE3SM#

Stem mount extension

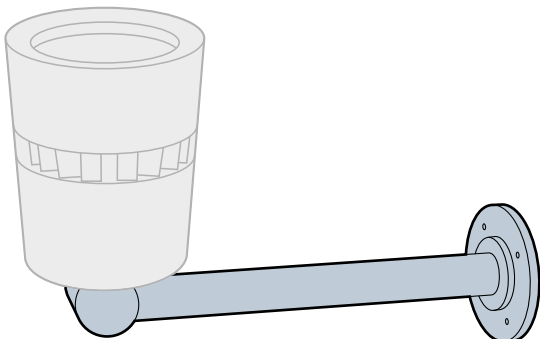

For use with Dyna Drum E3 stem mount variant

12" length
24" length

DE3SME12#
DE3SME24#

Up / down dual head wall mount

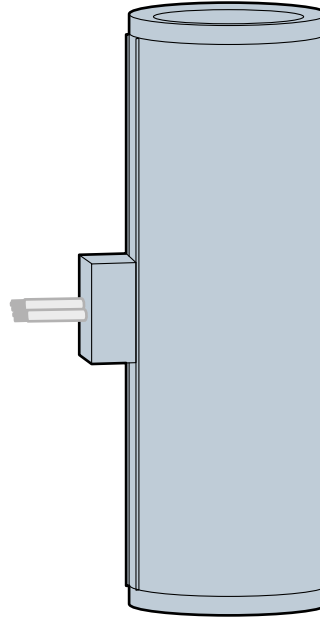

For use with Dyna Drum E3 stem mount variants

DE3DWM#



PROJECT	FIRM	ORDER #	TYPE	QTY
---------	------	---------	------	-----

Related components

Outdoor Linking System - See also pages 10, 11 and 12

Feed cables

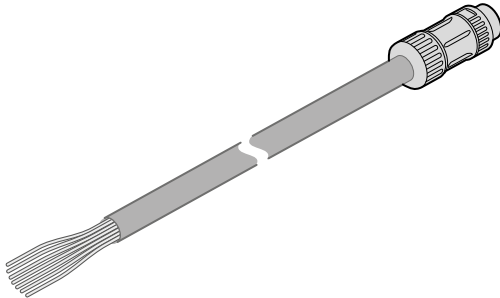

- | | |
|-------------|-------------------|
| 1' (30cm) | OLSF1#-V2 |
| 5' (1.5m) | OLSF5#-V2 |
| 10' (3m) | OLSF10#-V2 |
| 25' (7.6m) | OLSF25#-V2 |
| 50' (15.2m) | OLSF50#-V2 |

= color: G-Gray, B-Black, W-White, C-Custom (RAL# required)

Link cables

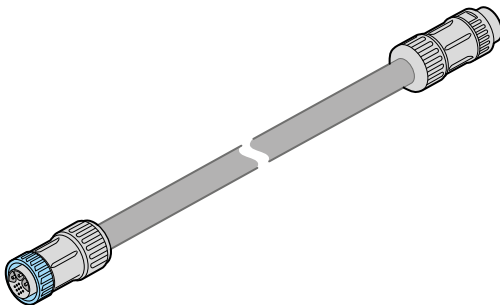

- | | |
|-------------|-------------------|
| 1' (30cm) | OLSL1#-V2 |
| 5' (1.5m) | OLSL5#-V2 |
| 10' (3m) | OLSL10#-V2 |
| 25' (7.6m) | OLSL25#-V2 |
| 50' (15.2m) | OLSL50#-V2 |

= color: G-Gray, B-Black, W-White, C-Custom (RAL# required)

End cap with DMX termination

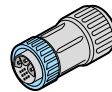

- | | | |
|-------|----------------|-------|
| Part# | OLSEC-B | Black |
| | OLSEC-W | White |

T-junction

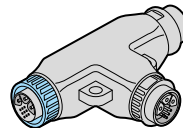

- | | | |
|-------|----------------|-------|
| Part# | OLST2-B | Black |
| | OLST2-W | White |

Y-junction

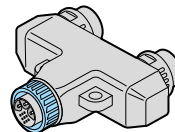

- | | | |
|-------|----------------|-------|
| Part# | OLSY2-B | Black |
| | OLSY2-W | White |

Note: Stem mount models, with their bare tail connections, are not directly compatible with the Acclaim Outdoor Link System.



PROJECT	FIRM	ORDER #	TYPE	QTY
---------	------	---------	------	-----

Related components

Signal converters (see page 14)

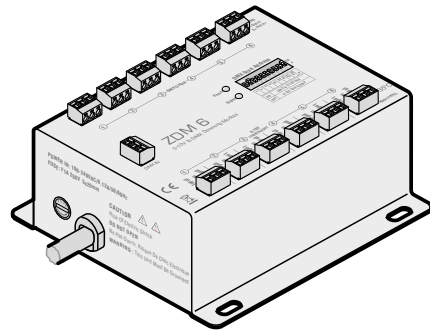

Multi-channel (0-10V) converter

ZDM6

Test and configuration tool kit

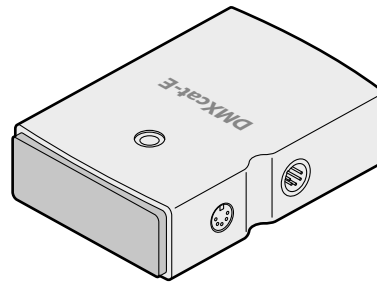

DMXcat-E

DMX/RDM, ArtNet, sACN, SMPTE LTC and Midi test/configuration tool

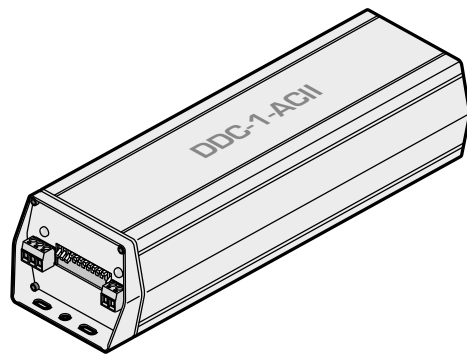

DALI multiple channel converter

DDC1AC

Wireless DMX transceiver

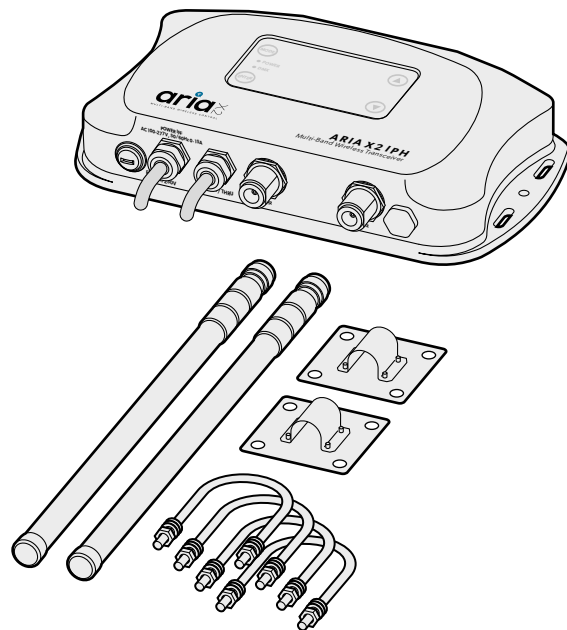

Aria X2 IPH multi-band wireless transceiver with two antennas, two antenna wall brackets and four U-bolts

AX2165



PROJECT	FIRM	ORDER #	TYPE	QTY
---------	------	---------	------	-----

Dimensions

Yoke mount model

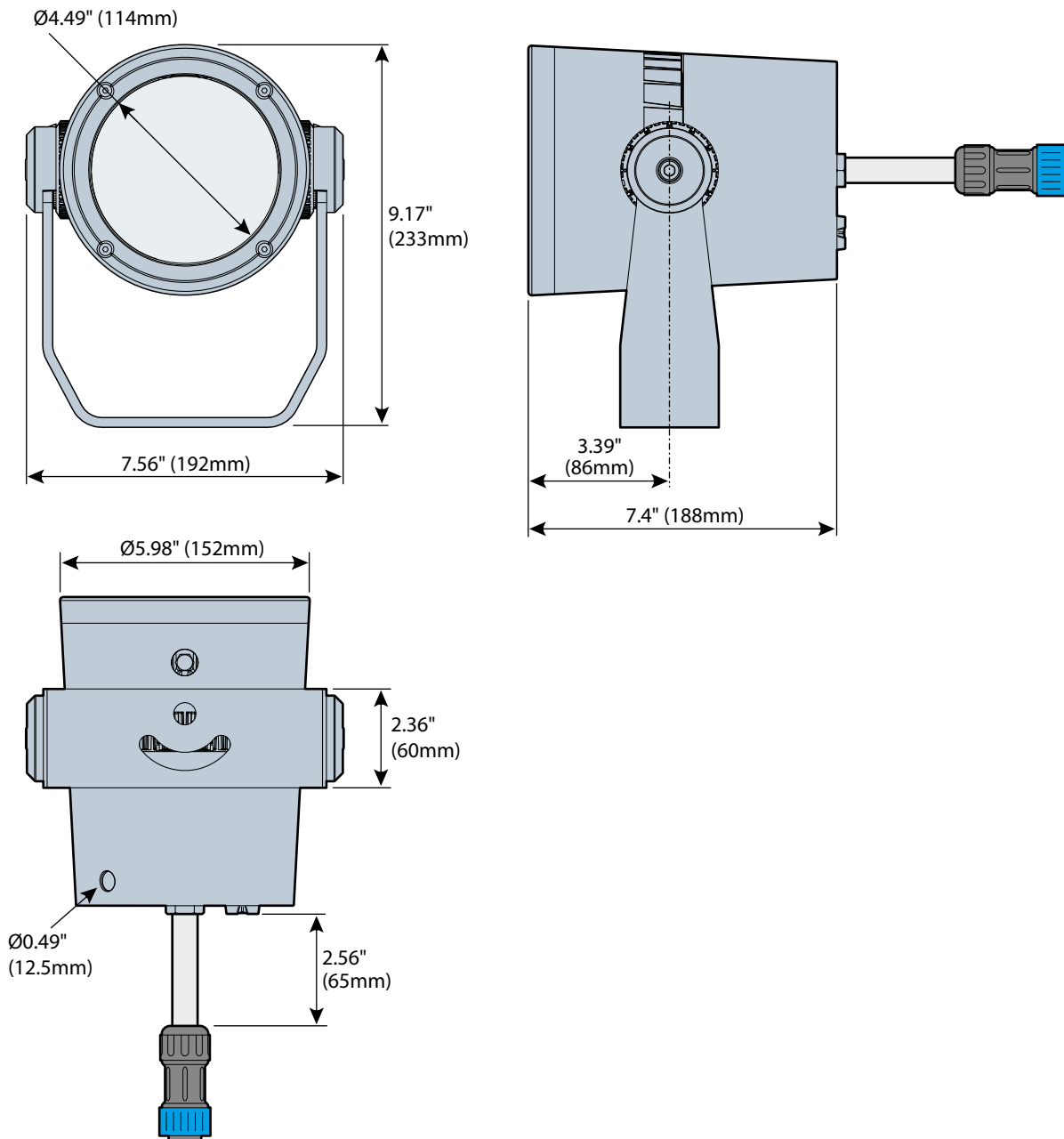

PROJECT	FIRM	ORDER #	TYPE	QTY
---------	------	---------	------	-----

Dimensions

Stem mount model

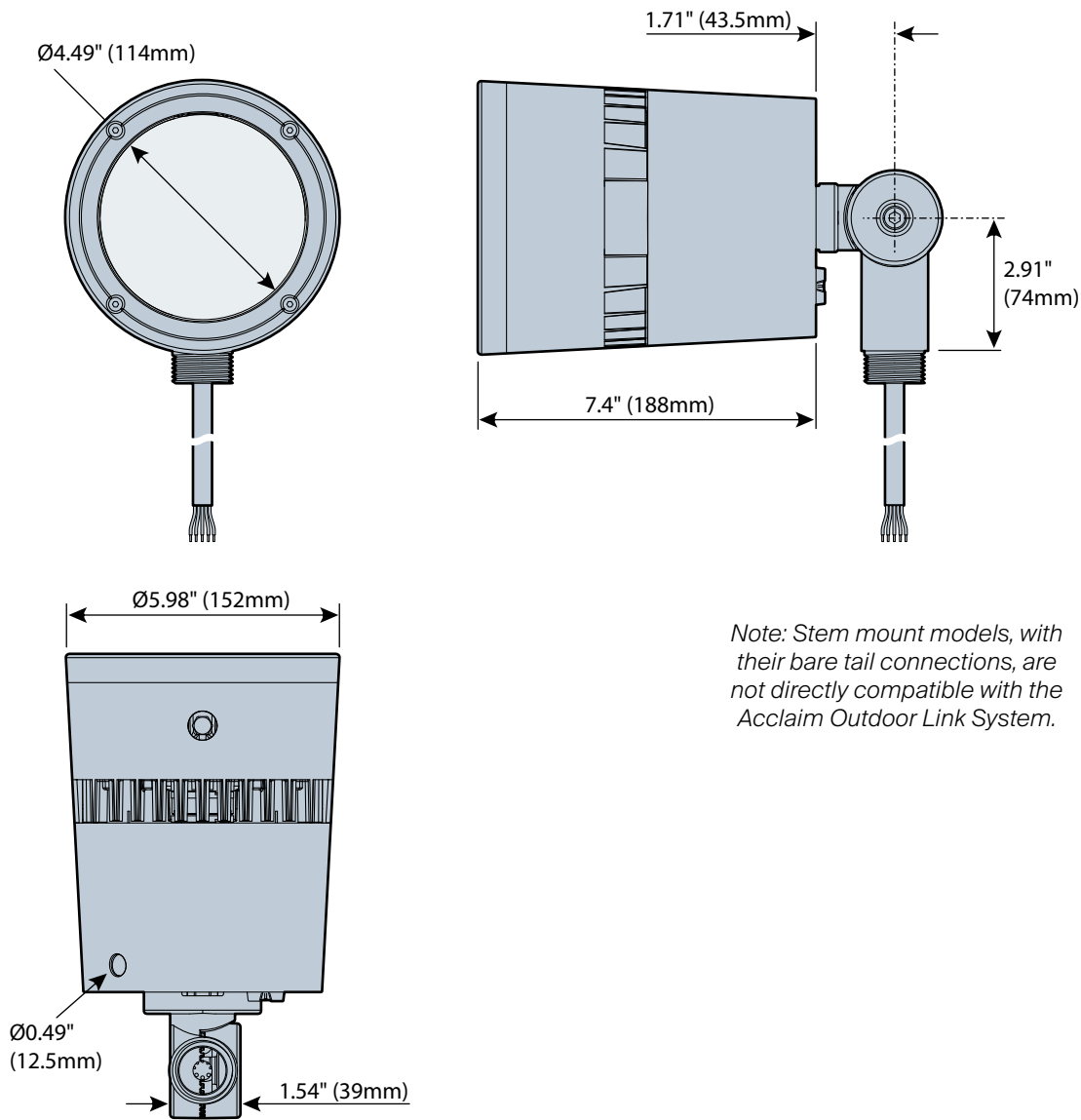

Note: Stem mount models, with their bare tail connections, are not directly compatible with the Acclaim Outdoor Link System.



PROJECT FIRM ORDER # TYPE QTY

Dimensions - OLS items

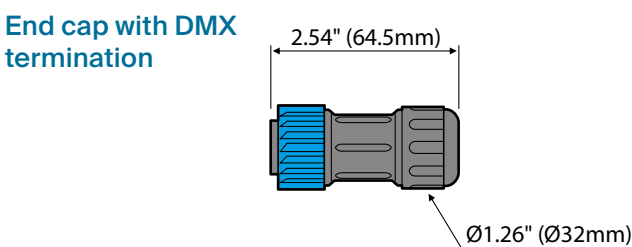
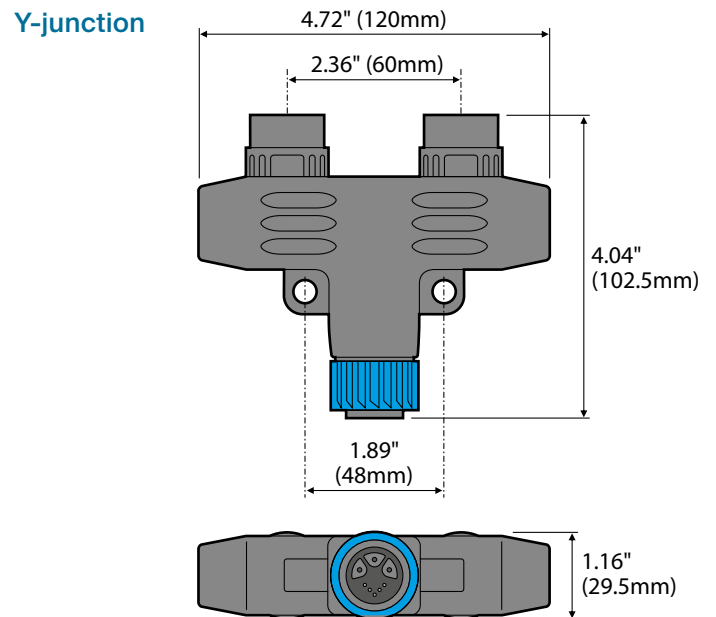
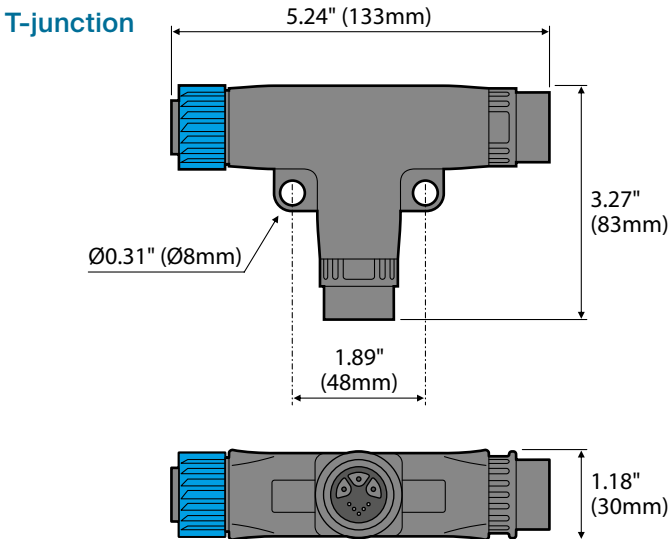
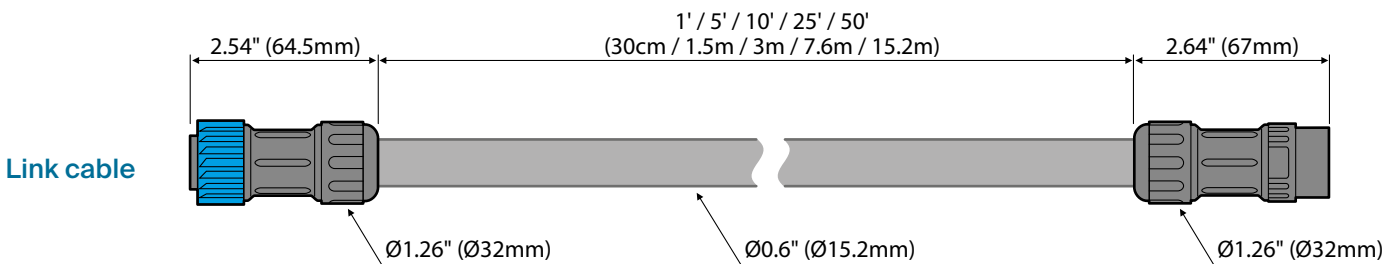
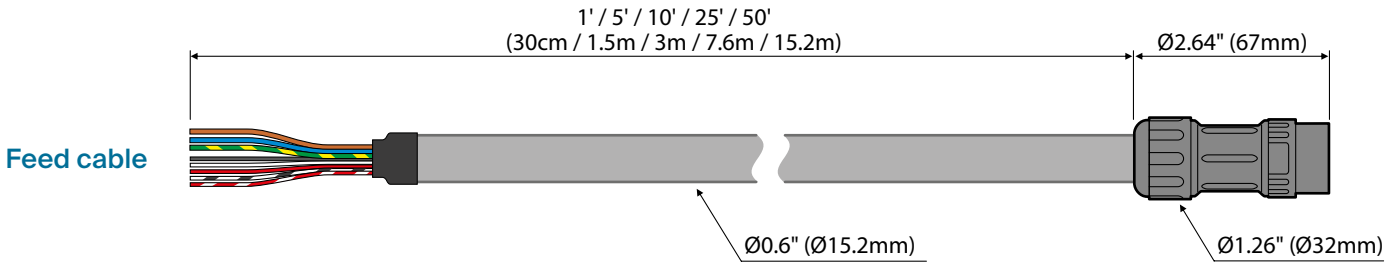

Note: Stem mount models, with their bare tail connections, are not directly compatible with the Acclaim Outdoor Link System.



PROJECT _____ FIRM _____ ORDER # _____ TYPE _____ QTY _____

Typical OLS configuration

The Dyna Drum E3 (yoke variant) connector is directly compatible with the Outdoor Link System, which greatly simplifies the task of distributing power and control to multiple fixtures:

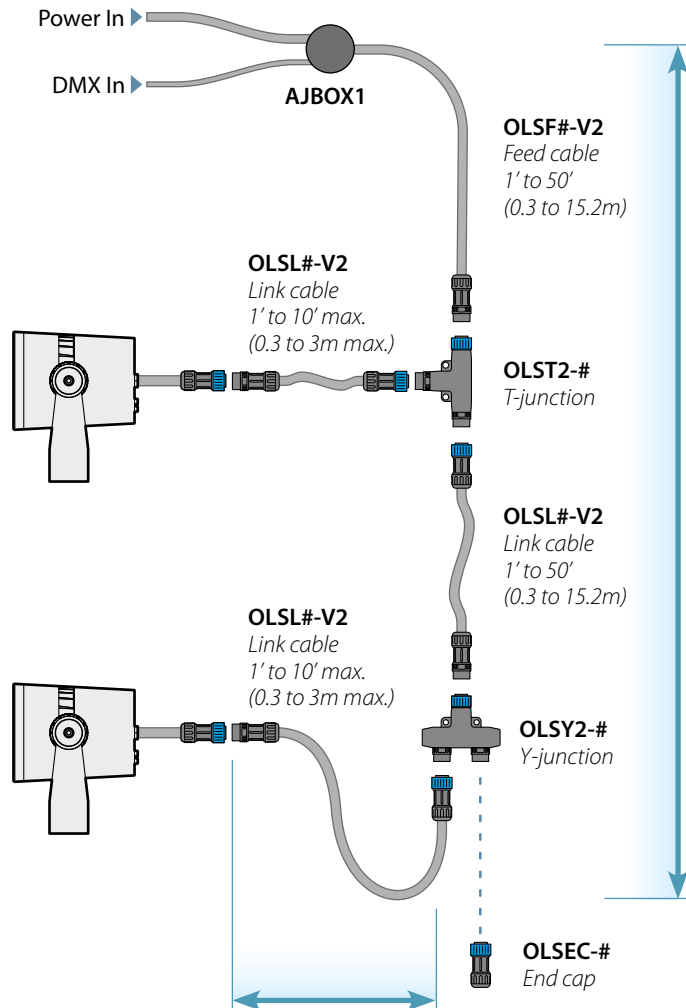

The total length from a T-junction to a fixture must not exceed 10' (3m) in length.

A terminator must be fitted to the final T-junction to simultaneously protect the live connections and correctly terminate the DMX control feed.

Maximum fixtures and cable lengths in a single OLS run:
 120VAC: 32x Dyna Drum E3 / 150'
 230VAC: 32x Dyna Drum E3 / 300'
 277VAC: 32x Dyna Drum E3 / 350'

Power and control wiring

Dyna Drum E3 models are supplied with a combined power and control cord (roughly 5 feet, 1.5m in length and with bare wire tails).

The color designations for the supplied feed in cable are as follows:

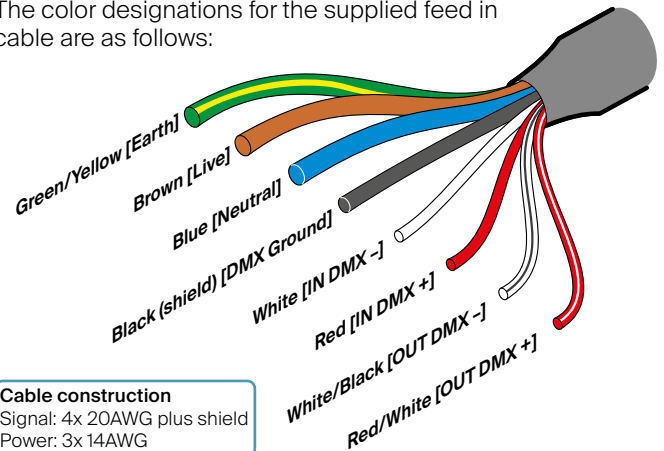

Power

The fixture power requirements are as follows:

- Voltage: 100-277VAC 50/60Hz
- Power: **50W**

Note: Acclaim recommends taking proper precautions for external surge protection, as control and power electronics can be damaged by major events. Ensure that the mains power is supplied from a suitably protected source and initial connections are made within IP rated enclosures. Acclaim recommends Belden 9842 or approved equivalent for all DMX wiring applications.

Note: The Acclaim AJBOX1 includes internal surge protection circuitry.

Control wiring

DMX cable recommendations:

- Indoor exposed or in conduit above grade: *Belden 9842*
- Indoor plenum: *Belden 82842*
- Outdoor exposed, direct burial, or inside conduit below grade: *Belden 3107DB*

Alternatives must meet **all** of the following requirements:

- **Construction**
Shielded, twisted pair (or multi-pair).
- **Impedance**
Between 90 and 120Ω.
- **Capacitance**
15pF or less.



PROJECT	FIRM	ORDER #	TYPE	QTY
---------	------	---------	------	-----

OLS connectors

The Outdoor Link System uses matching IP67-rated connectors throughout, each of which combines AC power and DMX control. A simple color code is used:

- Connectors with blue collars are inputs,
- Connectors with black collars (white option available) are outputs.

The blue collars form the locking and release mechanism ➔

Note: Stem mount models, with their bare tail connections, are not directly compatible with the Acclaim Outdoor Link System.

OutdoorLink
system

To make a link

Simply align a black and a blue connector and push them together with a click.

To break a link

Twist and hold the blue collar while you withdraw the black connector.

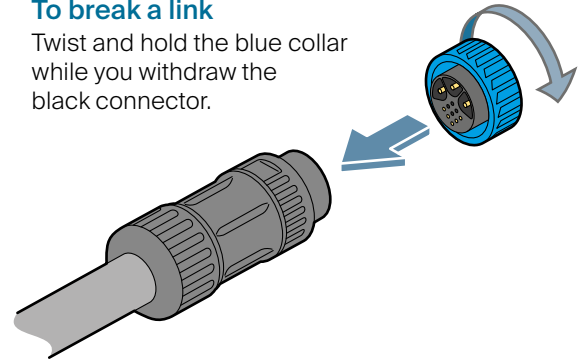

OLS Junctions

Two types of OLS junctions are available: T-junctions and Y-junctions. Electrically they are identical, they both split one input into two power/control outputs.

Y-junction

Most useful when the next fixtures are located in the same direction from the junction.

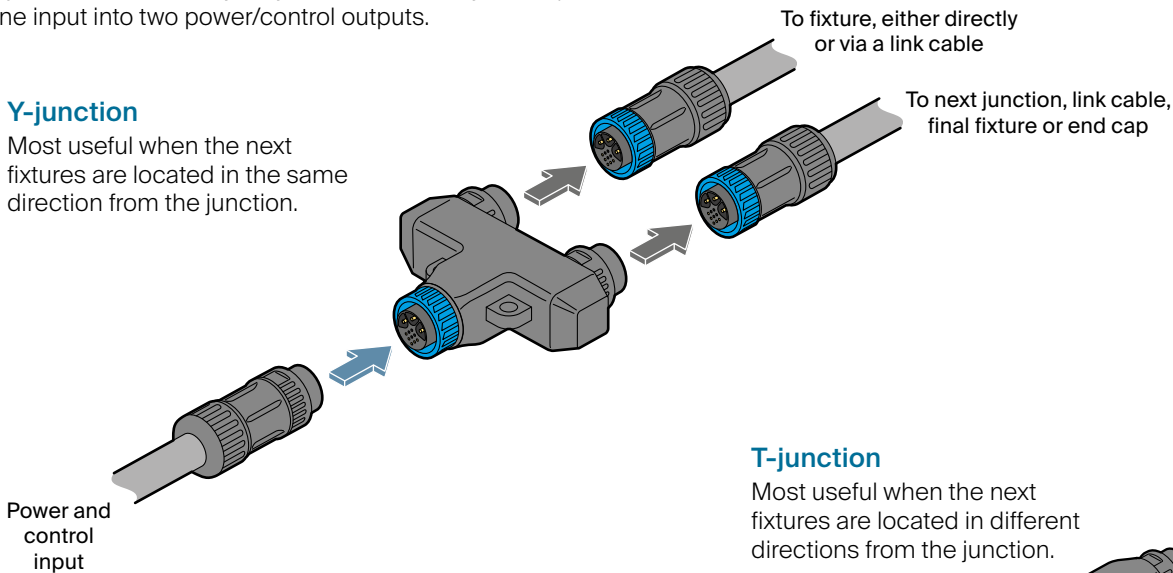

T-junction

Most useful when the next fixtures are located in different directions from the junction.

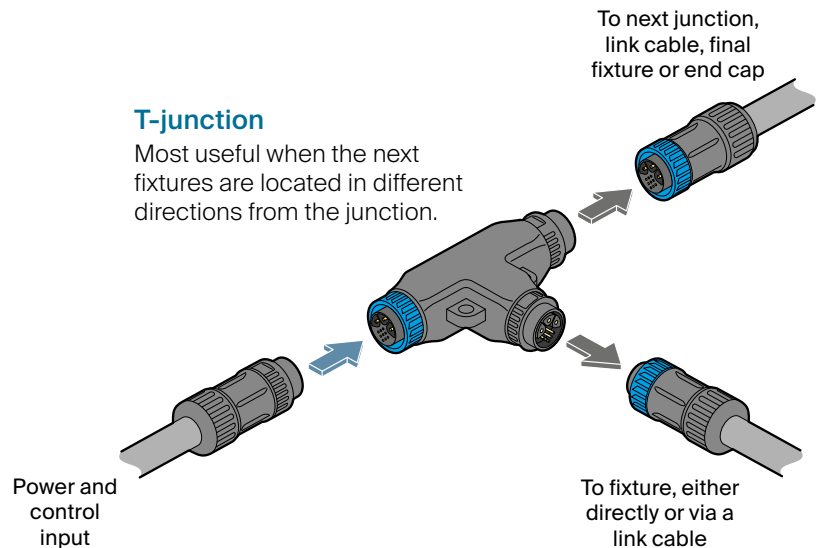

PROJECT FIRM ORDER # TYPE QTY

CCT Select color mixing

Dyna Drum E3 fixtures with the RGBAL emitter option allow you to mix saturated and pastel colors in addition to calling up any color temperature of white (using a dedicated CCT control channel). The special mode uses seven channels to provide full control.

Mixing saturated and pastel colors individually

Use DMX channels 1 to 5 to mix the required shade.

Use channel 7 to determine the overall output intensity.

Note: **Channel 6 must be at zero.**

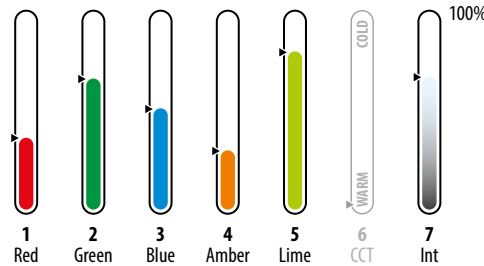

Choosing a temperature of white

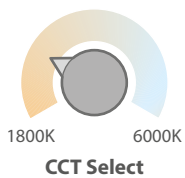

Use DMX channel 6 to select the required correlated color temperature (CCT) ranging from 1800K (at 1%) to 6000K (at 100%).

Use channel 7 to control the overall output intensity.

Note: When channel 6 receives any value other than zero, the input values of channels 1 to 5 will be ignored.

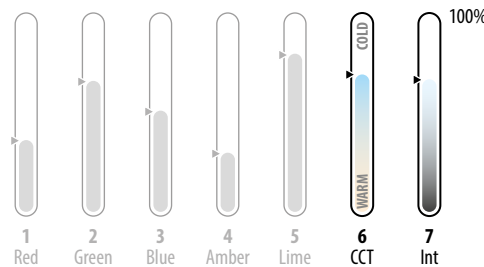

DMX value	Color temp
0	Off
001-004	1800K
005-008	1900K
009-012	2000K
013-016	2100K
017-020	2200K
-	-
-	-
233-236	5600K
237-240	5700K
241-245	5800K
246-250	5900K
251-255	6000K

16-bit control

To provide even finer dimming responses, Dyna Drum E3 fixtures also feature a 16-bit version of the above control mode. Using 13 channels in total, each color (plus the intensity) uses high and low bytes (2 channels each) to enact 65,536 dimming steps rather than the usual 256. The CCT Select channel remains as a single 8-bit word.

Note: A full list of DMX values for each color temperature are provided in the Dyna Drum E3 user guide.



PROJECT	FIRM	ORDER #	TYPE	QTY
---------	------	---------	------	-----

Alternative control inputs

Dyna Drum E3 fixtures use DMX as their native control method, however, it is possible to use other common control protocols when required, such as 0-10V (source or sink) or DALI.

Control inputs via converters

- DMX - connect a DMX input directly to the feed cable.
- 0-10V - use an Acclaim Lighting ZDM 6 to convert one or more analog control feeds into a combined DMX feed.
- DALI - use an Acclaim Lighting DDC-1-AC to convert one or more DALI channels into a combined DMX feed.

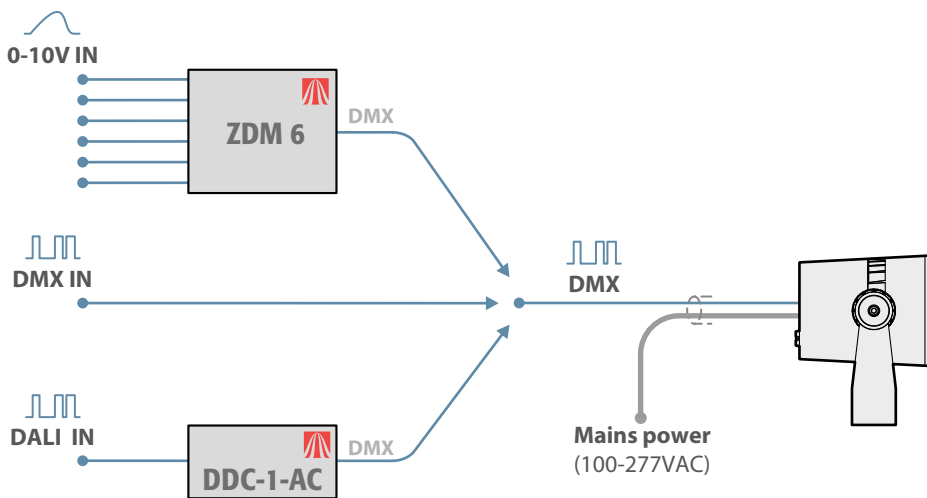

When using Acclaim Lighting ZDM 6 or DDC-1-AC modules it is possible to convert multiple inputs into separate DMX channels within a consolidated feed. The ZDM 6 can convert up to six 0-10V inputs into DMX channels, whereas the DDC-1-AC can convert a maximum of 64 DALI channels (although large numbers of channels are not recommended due to the timing limitations of the DALI standard).

Wireless DMX control

Each Dyna Drum E3 fixture contains an Aria X2 wireless DMX receiver as standard, which can greatly simplify the deployment of multiple fixtures in spaces that contain no control wiring infrastructure. A single Aria transmitter can control unlimited Dyna Drum E3 fixtures, at distances up to 2,000 feet (609m).

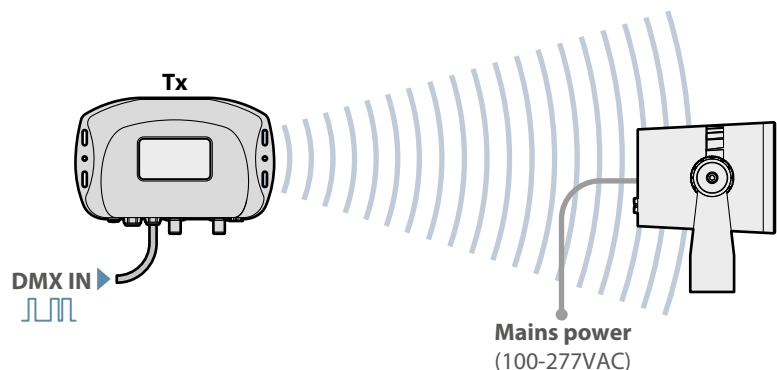

PROJECT	FIRM	ORDER #	TYPE	QTY
---------	------	---------	------	-----

Modular flexibility

Like all Acclaim Lighting products, Dyna Drum E3 fixtures are designed and built for the long haul in professional environments. In the unlikely event of failure during the lifetime of a fixture, it is reassuring to know that a solution is ready to return to 100% operation in the shortest possible downtime. Our **CoreSwap Technology** ensures that only the affected module need ever be swapped out, whether that be in our service center or at your on-site installation.

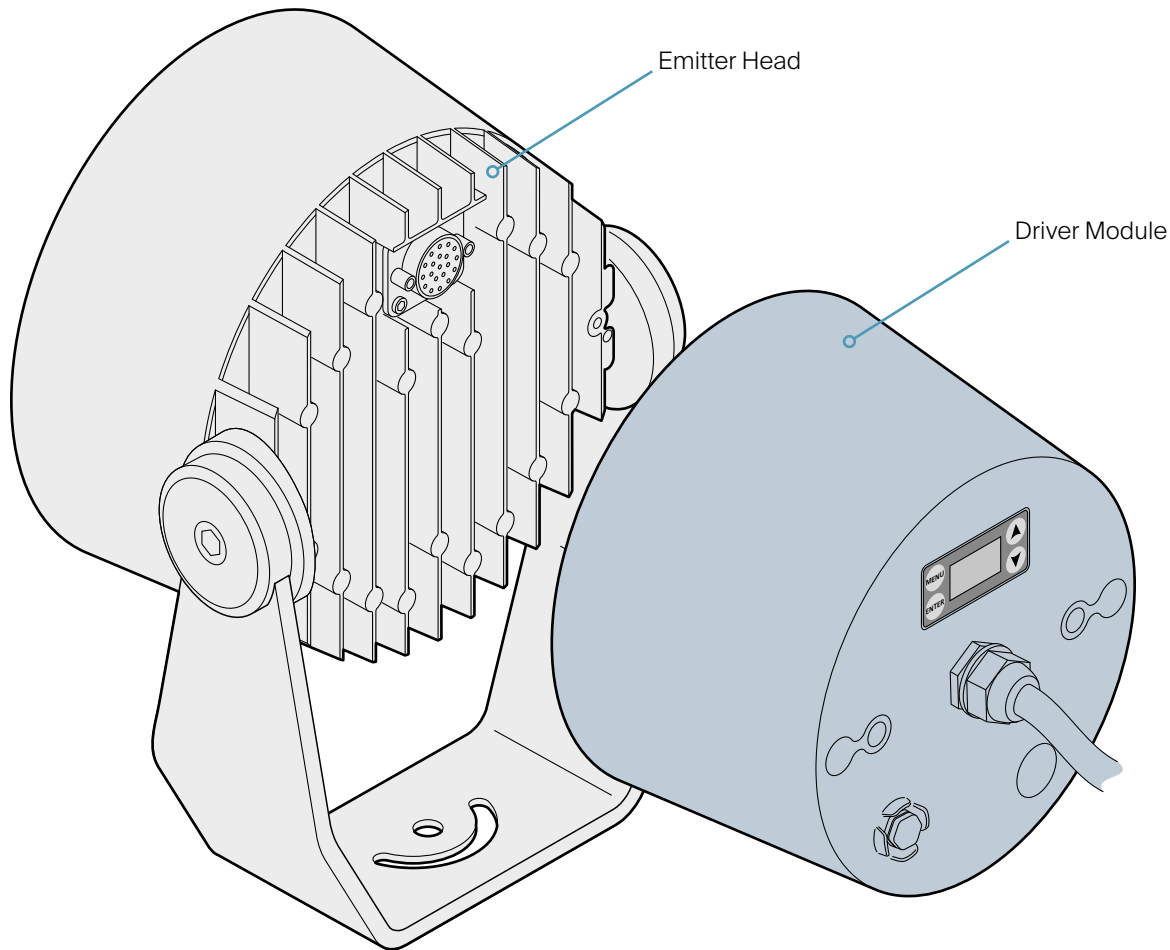

For full installation details, please refer to the **user guide**, available for free download here:

