

ART-4 Pro

CONTENTS

| | |
|----------------------------------|-----------|
| INTRODUCTION | 2 |
| Welcome | 2 |
| Safety | 2 |
| Supplied items | 3 |
| INSTALLATION | 4 |
| Mounting | 4 |
| Connections | 5 |
| Power adapter | 6 |
| Linking multiple panels | 7 |
| CONFIGURATION | 8 |
| Switching between on and standby | 8 |
| One-touch power mode | 8 |
| On/standby fadetime | 8 |
| Button clicks | 9 |
| Restoring default settings | 9 |
| Synchronizing linked panels | 9 |
| Programs (color chases) | 10 |
| Brightness | 10 |
| Speed | 11 |
| Colors | 12 |
| OPERATION | 13 |
| Using static colors and scenes | 13 |
| FURTHER INFORMATION | 14 |
| Specifications | 14 |
| Dimensions | 15 |
| Limited product warranty | 17 |

INTRODUCTION

WELCOME

Welcome to the ART-4 Pro panel from Acclaim Lighting. This simple wall-mount DMX controller is designed for controlling RGB and RGBW lighting fixtures. It features combined DMX and PWM outputs, the latter of which can directly drive 12-24VDC fixtures such as LED tape.

Note: The R, G, B and W channels are output on DMX addresses 1 to 4 respectively and then repeated throughout the DMX address space: 5 to 8, 9 to 12, 13 to 16, 17 to 20, etc.

The clean and tidy front panel uses a touch sensitive scroll ring and buttons to simplify programming and operation. Multiple dynamic color chases as well as static color mixes can be created for quick selection.

A compact power supply is provided with each panel. Multiple panels can be linked to provide control access to the same lighting fixtures from many (up to 32) separate locations.

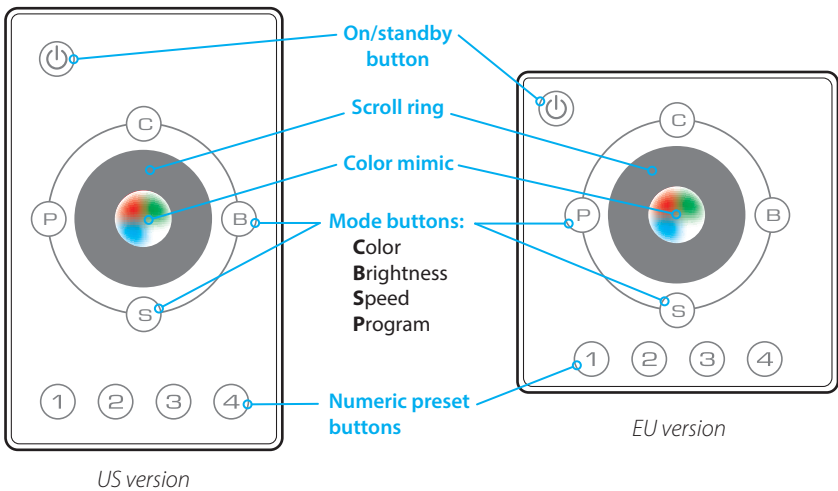

SAFETY

- Ensure that the power input is supplied from a correctly fused and environmentally protected location.

SUPPLIED ITEMS

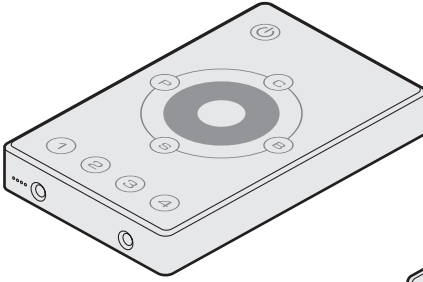

**ART-4 Pro panel
main body plus back plate
(US model shown)**

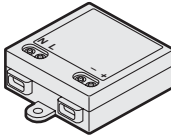
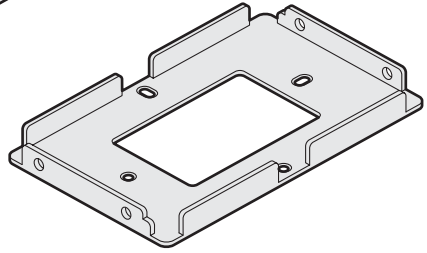

12VDC power adapter

INSTALLATION

ART-4 Pro panels are available in two formats: US and EU, to suit the differing single gang electrical box standards in those regions. See "Dimensions" on page 15.

A compact 12VDC power adapter is supplied with each panel and this requires a fused mains (100 to 240VAC, 6W) supply.

MOUNTING

TO OPEN THE PANEL

- 1 Remove the four small screws from the top and bottom edges of the panel.
- 2 Gently pull the main body of the panel away from the back plate.

Note: It may be necessary to gently lever the back plate away from the main body with a small implement. If you do so, take great care not to damage any of the micro circuitry inside the main body.

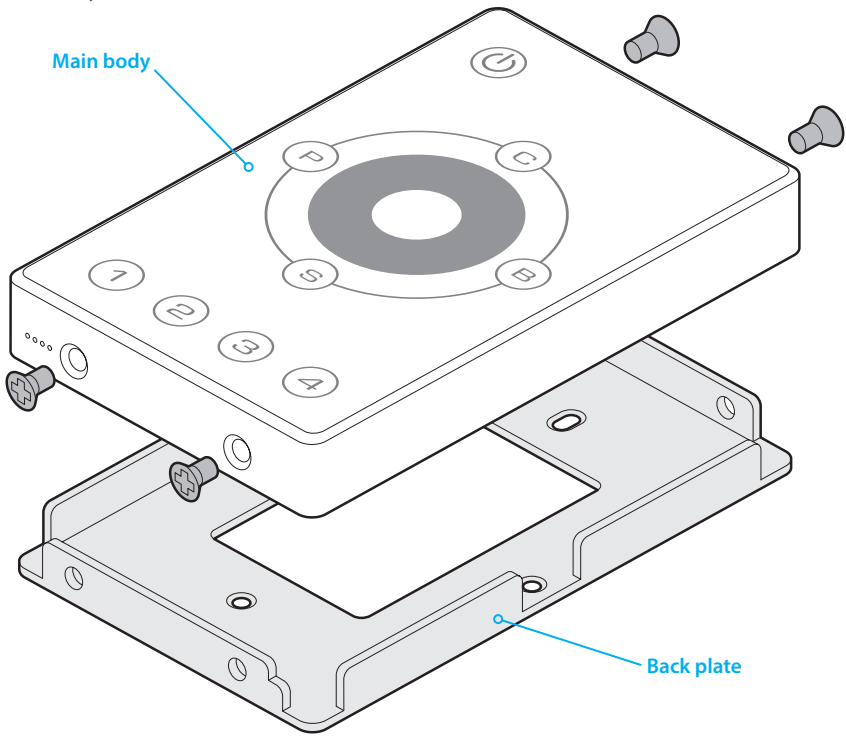

- 3 Fix the back plate to a suitable single gang electrical wall box (not supplied) and, if possible, locate the supplied 12VDC power adapter inside the wall box.
- 4 Make all necessary connections and fit the main body to the back plate.
- 5 Insert the four screws removed earlier.

CONNECTIONS

The panel has four connector blocks at its rear, with the following functions:

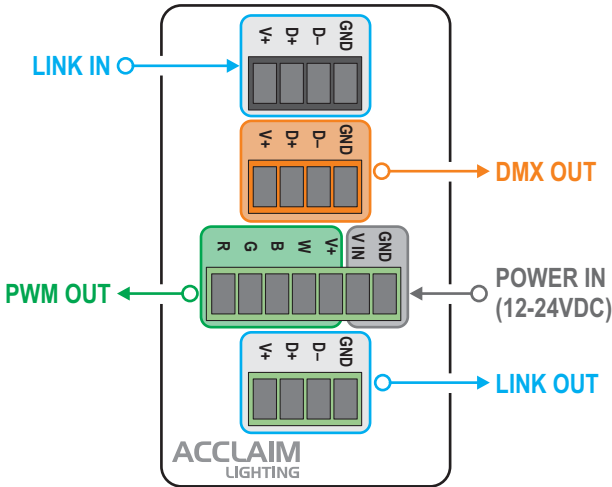

POWER IN

Each panel requires a DC power input of between 12 and 24VDC. The panel consumes just 1.5W itself. The power adapter supplied with each panel provides 12VDC with a maximum power output of 6W.

IMPORTANT: If LED fixtures are to be powered directly from the panel using the PWM output, you must take care to not exceed the current handling capacity of the panel. The panel can support a 2A current draw on each of the channels: R, G, B and W, equating to 24W per channel at 12VDC supply and 48W per channel at 24VDC supply. If the PWM outputs are used, it is highly likely you will need to use a more powerful adapter to feed the panel and LED fixture.

DMX OUT

Provides a link to DMX-enabled lighting fixtures. Use the GND, D- and D+ terminals to send control data to the fixtures. The power draw of the fixtures will be completely separate from the panel.

DMX addressing: The R, G, B, W channels are output on addresses 1 to 4 respectively and then repeated throughout the DMX address space: 5 to 8, 9 to 12, 13 to 16, 17 to 20, etc.

PWM OUT

Allows you to attach and control LED fixtures, such as LED tape, directly from the panel. See the IMPORTANT statement above when selecting and connecting LED fixtures directly. Fixtures must be of the constant voltage, common anode type.

LINK IN and LINK OUT

Allows two or more panels to be linked so the lighting fixtures can be controlled from multiple locations. The GND, D- and D+ terminals need to be connected from the LINK OUT connector of one panel to the LINK IN connector of the next. Up to 32 panels can be linked in a daisychain arrangement. The V+ connection should not be used to transfer power from one panel to another.

POWER ADAPTER

The supplied compact power adapter can accept mains inputs from 100 to 240VAC, 50/60Hz and provides 12VDC at a maximum of 6W. This is sufficient to power the panel (which draws 1.5W) but, if the PWM outputs are used to directly drive LEDs, will be unable to support most lighting fixtures.

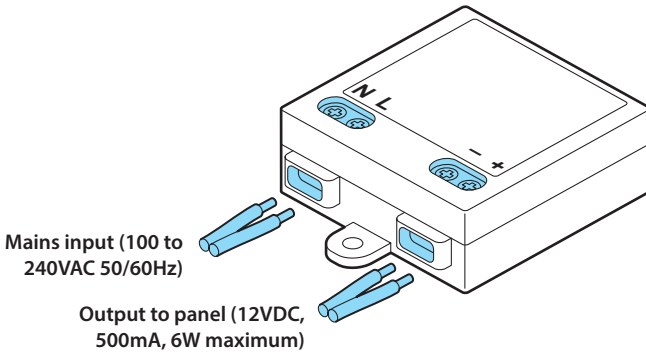

The power adapter is a Class II, double insulated device and requires no earth bond.

LINKING MULTIPLE PANELS

Each ART-4 Pro includes link connectors to allow two or more panels to be linked so the lighting fixtures can be controlled from multiple locations. The GND, D- and D+ terminals need to be connected from the LINK OUT connector of one panel to the LINK IN connector of the next. Up to 32 panels can be linked in a daisychain arrangement. The V+ connection should not be used to transfer power from one panel to another.

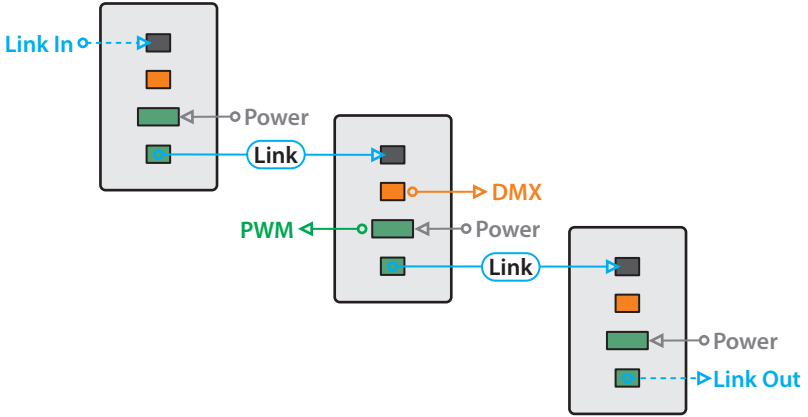

The communication characteristics are similar to DMX, so standard DMX or CATx cables can be used. Distance restrictions are also similar to those for DMX.

See also "Synchronizing linked panels" on page 9.

CONFIGURATION

The ART-4 Pro panel uses touch sensitive buttons plus a touch sensitive scroll ring, which allows you to easily increase and decrease settings by running your finger around it in clockwise or counterclockwise directions.

At the center of the scroll ring is a four-color indicator which mimics the RGBW output of the fixtures being controlled by the panel.

At the base of the panel are four numeric preset buttons which provide quick access to your pre-programmed color mixes and color chase scenes.

Each button press and scroll ring movement is accompanied by an audible click. If required, you can disable the clicks to make the panel run silently. See "Button clicks" on page 9 for details.

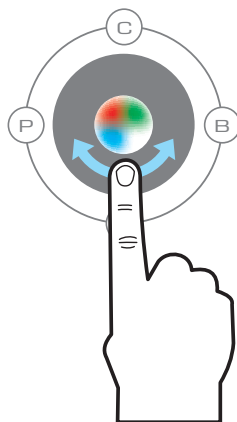

SWITCHING BETWEEN ON AND STANDBY

Once power is applied, press and hold the **⏻** button for **two** seconds to switch the panel between on and standby.

Whenever the panel is in standby, all connected lighting fixtures will be extinguished and the **⏻** button will glow dimly to assist with locating it in the dark.

Note: When switched on, the panel will return to whichever mode was running when standby was previously invoked - using the standard, or chosen, fadetime (see "On/standby fadetime").

ONE-TOUCH POWER MODE

If required, you can configure the panel to switch between on and standby using just a quick press of the **⏻** button, rather than the need to press and hold it for two seconds. Additionally, when one-touch mode is enabled, the panel will switch on when any button is pressed, not just the **⏻** button.

TO TOGGLE ONE-TOUCH POWER MODE

- While the panel is on, simultaneously press and hold the **P** and **⏻** buttons for roughly ten seconds, until all buttons momentarily flash.

ON/STANDBY FADETIME

You can determine how the panel fades (or snaps) the output of the connected fixtures when changing between the on and standby states. The default fadetime is two seconds.

TO CHOOSE AN ON/STANDBY FADETIME

- 1 Press and hold the **⏻** button for five seconds, until it begins flashing.
- 2 Press a button to choose the required fadetime:
 - **1** 1 second fade
 - **2** 2 second fade
 - **3** 3 second fade
 - **4** 4 second fade
 - **P C B** or **S** No fade (snap)

BUTTON CLICKS

Each button press (or change of setting using the scroll ring) is accompanied by an audible click and other operations are confirmed using bleeps (in addition to flashing buttons). If required, you can disable the clicks and bleeps so the panel runs silently.

Note: If button clicks are enabled, when you use the scroll ring and then reach a minimum or maximum setting, the clicks will cease despite any further scrolling. If button clicks are disabled, minimum and maximum scroll positions will instead be indicated by all of the buttons flashing rapidly three times.

TO TOGGLE THE BUTTON CLICKS

- Press and hold the **1**, **2**, **3** and **4** buttons until all buttons flash momentarily.

RESTORING DEFAULT SETTINGS

If required, you can restore the panel to its default settings. When this is done, all recorded color mixes and scenes will be removed from the numeric preset buttons. Any other panels which are linked to the one being restored to default settings, will not be affected unless you then synchronize them from the restored panel.

TO RESTORE DEFAULT SETTINGS

- While the panel is on, press and hold the **P** and **B** buttons for ten seconds, until all buttons flash once.

SYNCHRONIZING LINKED PANELS

When two or more ART-4 Pro panels are linked (see “Linking multiple panels” on page 7) to control the same set of lighting fixtures, the panels can either run different color presets or you can synchronize your color mixes and scenes from one panel to all of the others. Any panel within a linked group can be made to synchronize its data with all others, it does not have to be the panel that is directly linked to the lighting fixtures.

Note: If you wish to synchronize presets with only some of the linked panels, leaving others with their own presets intact, ensure the latter ones are in standby before you perform the synchronization.

TO SYNCHRONIZE WITH LINKED PANELS

- 1 Switch on all panels that need to be synchronized.
- 2 On the panel which contains the data to be synchronized, simultaneously press and hold the **P C B** and **S** buttons for five seconds, until all buttons begin flashing.
- 3 Press the **S** button. The synchronization process will take roughly ten seconds and during that time, the P C B and S buttons will illuminate in sequence.

Once the synchronization is complete, all panels will return to normal operation.

PROGRAMS (COLOR CHASES)

The panel includes ten built-in color mixing programs (color chases) that can be selected. There is also an auto mode which sequentially cycles through the ten programs. By choosing a program, optionally adjusting the speed and brightness and then storing the result in one of the numeric preset buttons, you are creating a **Scene** that can be easily recalled at any time.

TO CHOOSE A PROGRAM AND STORE A SCENE

- 1 While the panel is on, press and hold the **P** button for one second, until it illuminates.
- 2 Use the scroll ring to cycle through the built-in programs (plus the auto mode) until you find an appropriate one.
- 3 Optionally, adjust the speed of the color changing program - see "Speed" on page 11.
- 4 Optionally, adjust the brightness of the fixture output - see "Using static colors and scenes" on page 13.
- 5 When all parameters are correct, store the result as a scene: Press and hold one of the numeric preset buttons for two seconds.

Note: See also "Using static colors and scenes" on page 13.

BRIGHTNESS

You can determine the brightness of the connected lighting fixtures and, if required, you can store the brightness levels within programs (scenes) and static color mixes.

TO ADJUST BRIGHTNESS

- 1 Display the color mix or program whose brightness you wish to alter - see "Colors" on page 12 or "Programs (color chases)" above.
- 2 Press and hold the **B** button for one second, until it illuminates.
- 3 Use the scroll ring to increment (clockwise) or decrement (counter clockwise) the brightness of the lighting fixtures output.
- 4 Optionally, adjust the speed of the color changing program - see "Speed" on page 11.
- 5 When all parameters are correct, store the result: Press and hold one of the numeric preset buttons for two seconds. The result will be automatically stored either as a static color mix or a scene, as appropriate.

Note: See also "Using static colors and scenes" on page 13.

SPEED

When running any of the programs (color chases), you can adjust the speed of color change, ranging from fractions of a second to tens of minutes. By choosing a program, optionally adjusting the speed and brightness and then storing the result in one of the numeric preset buttons, you are creating a **Scene** that can be easily recalled at any time.

TO ADJUST SPEEDS

- 1 Display the program whose speed you wish to alter - see “Programs (color chases)” on page 10.
- 2 Press and hold the **S** button for one second, until it illuminates.
- 3 Use the scroll ring to increment (clockwise) or decrement (counter clockwise) the speed of the selected program. The scroll ring adjustments range from the fastest (0.2 second) to the slowest (ten minutes).

Note: It is also possible to select even slower speeds, see “To choose ultra slow speeds” below.

- 4 Optionally, adjust the brightness of the fixture output - see “Using static colors and scenes” on page 13.
- 5 When all parameters are correct, store the result as a scene: Press and hold one of the numeric preset buttons for two seconds.

Note: See also “Operation” on page 13.

TO CHOOSE ULTRA SLOW SPEEDS

It is possible to choose speeds even slower than the ten minutes available on the scroll ring.

- 1 Use the scroll ring in a counter clockwise direction to get to the slowest standard speed. When you reach it, the four numeric preset buttons will flash.
- 2 Press a numeric preset button to choose the required ultra slow speed:

- **1** 10 minutes
- **2** 20 minutes
- **3** 30 minutes
- **4** 40 minutes

Note: Once the ultra slow speed is selected, the functions of the four numeric preset buttons return to their usual settings.

COLORS

You can create static color mixes and then store them to any of the four numeric preset buttons. You can also optionally determine the rate of change from one static color mix to another.

TO MIX AND STORE COLORS

- 1 While the panel is on, press and hold the **C** button for one second, until it illuminates.
- 2 Use the scroll ring to cycle through varying mixes of red, green, blue and white emitter to produce the desired effect.

Note: You can also adjust the brightness (see "Brightness" on page 10).

- 3 When the mix is correct, ensure that the **C** button is still lit, then press and hold any of the numeric preset buttons for two seconds to store it for instant recall.

TO CHOOSE A COLOR FADETIME

- 1 Press and hold the **C** button for five seconds, until all buttons flash once. The default fadetime is two seconds.
- 2 Press a button to choose the required fadetime:
 - **1** 1 second fade
 - **2** 2 second fade
 - **3** 3 second fade
 - **4** 4 second fade
 - **P C B** or **S** No fade (snap)

OPERATION

USING STATIC COLORS AND SCENES

In everyday use, there are two main ways to operate the panel: *Static colors* and *Scenes*.

- **Static colors** - these are available when the **C** button is lit and you can choose between any of the color mixes saved to the four numeric preset buttons. The chosen *color fadetime* will be used to transition from one static color mix to another as a button is pressed.

When **C** is lit, press any numeric preset button to recall a static color mix.

- **Scenes** - a Scene is a saved combination of a chosen program (color chase), a speed and a brightness level. Scenes are available when either the **P** or **S** buttons are lit and you can choose between the combinations saved to the four numeric preset buttons.

When **P** or **S** are lit, press any numeric preset button to recall a scene.

TO RECALL A STATIC COLOR MIX

- 1 Press and hold the **C** button for one second, until it illuminates.
- 2 Press any of the four numeric preset buttons to recall their saved color mixes. The optionally chosen fadetime (see "To choose a color fadetime") will be used to change from one color mix to another.

TO RECALL A SCENE

- 1 Press and hold either the **P** button or the **S** button for one second, until it illuminates.
- 2 Press any of the four numeric preset buttons to recall their saved scenes.

TO TOGGLE THE SCENE RECORD LOCK

Optionally, use this feature to prevent any new scenes from being recorded over existing ones. When the scene record lock is enabled, the **S** button is disabled.

- 1 Press and hold the **P** and **S** buttons for ten seconds until all buttons flash once.

TO MAKE TEMPORARY ADJUSTMENTS

During operation you can make temporary adjustments to all aspects of operation, such as the speed of a color chase within a scene, the overall brightness, etc.

- 1 Press and hold, for one second, the button of the attribute you need to adjust:

- **S** Speed
- **B** Brightness
- **C** Color
- **P** Program

- 2 Use the scroll ring to adjust the chosen attribute.

Note: The temporary changes you make will remain only until the next change of preset.

FURTHER INFORMATION

SPECIFICATIONS

| | |
|-----------------------|---|
| DMX output | 4 channels |
| PWM output | 4 channels, 100W maximum pass through |
| Interface | Touch sensitive wall panel |
| Multiple locations | Use the link out ports to connect up to 32 wall panels and to synchronise presets |
| Audio feedback | Tones can be toggled by holding buttons 1 to 4 simultaneously |
| Mounting | Single gang US or EU-type electrical box (not included) |
| Material | Aluminum housing, glass panel |
| Finish | White |
| IP rating | IP20, dry location |
| Operating voltage | 12-24VDC, 500mA (6W power adapter included, 100-240VAC) |
| Operating temperature | 32°F to 104°F (0°C to 40°C) |
| Weight | 0.3 lbs (140g) |

Certifications



DIMENSIONS

MAIN BODY (US VERSION)

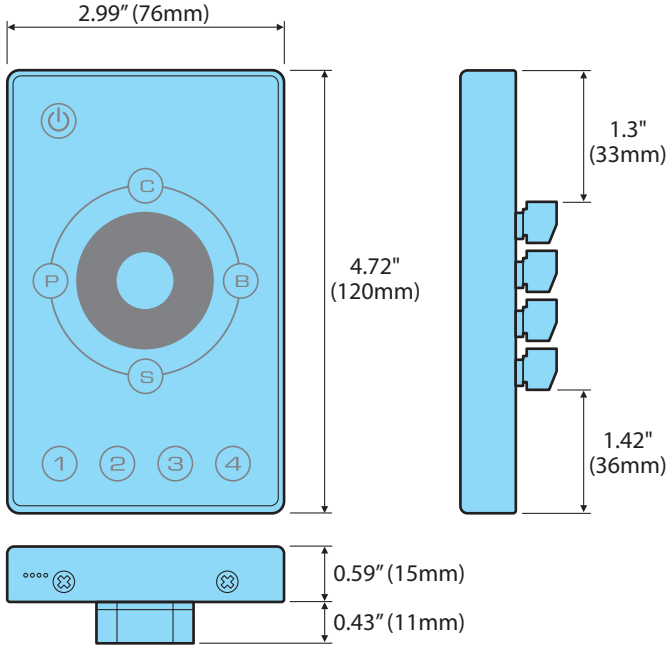

BACK PLATE (US VERSION)

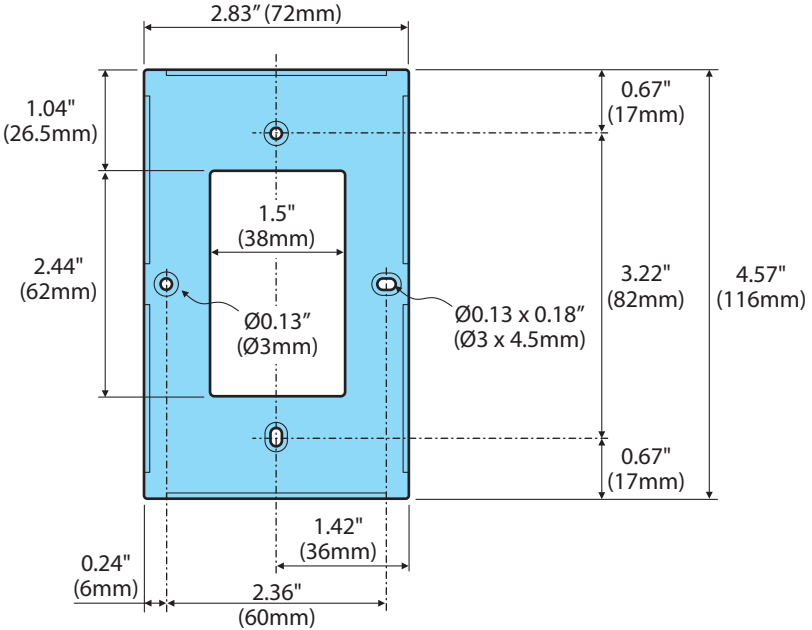

DIMENSIONS (CONT)

MAIN BODY (EU VERSION)

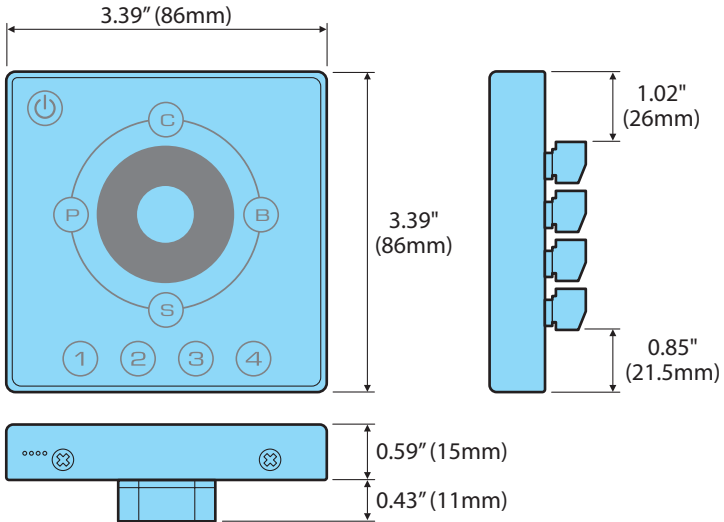

BACK PLATE (EU VERSION)

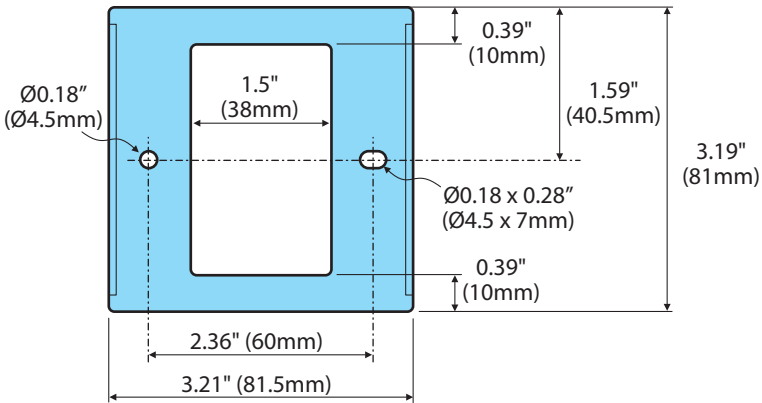

POWER SUPPLY

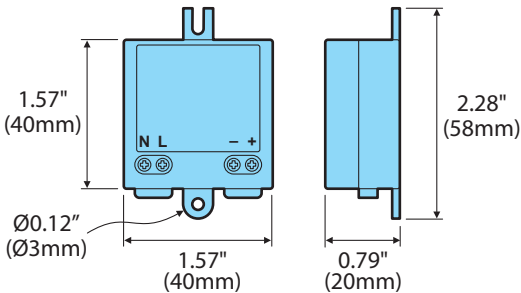

LIMITED PRODUCT WARRANTY

A. Acclaim Lighting™ hereby warrants, to the original purchaser, Acclaim Lighting finished products to be free of manufacturing defects in material and workmanship for a standard period of:

- Fixtures: 5 Years (1,825 days) from the date of purchase.
- Drivers, power supplies and accessories: 5 Years (1,825 days) from the date of purchase.
- Flex Products: 3 Years (1,095 days) from the date of purchase.
- Controllers: 2 Years (730 days) from the date of purchase.

It is the owner's responsibility to establish the date and place of purchase and warranty terms by acceptable evidence, at the time service is sought.

B. For warranty service, send the product only to the Acclaim factory. All shipping charges must be pre-paid. If the requested repairs or service (including parts replacement) are within the terms of this warranty, Acclaim Lighting will pay return shipping charges only to a designated point within the United States. If the entire instrument is sent, it must be shipped in its original package. No accessories should be shipped with the product. If any accessories are shipped with the product, Acclaim Lighting shall have no liability whatsoever for loss of or damage to any such accessories, nor for the safe return thereof. Acclaim reserves the right to replace the item with same or similar product at its discretion.

C. This warranty is void if the serial number has been altered or removed; if the product is modified in any manner which Acclaim concludes, after inspection, affects the reliability of the product; if the product has been repaired or serviced by anyone other than the Acclaim Lighting factory unless prior written authorization was issued to purchaser by Acclaim Lighting; if the product is damaged because not properly maintained as set forth in the instruction manual.

D. This is not a service contract, and this warranty does not include maintenance, cleaning or periodic check-up nor do we guarantee as part of this warranty any lumen performance during period. Parts not covered by this warranty include: fuses, external power supplies, third party items not manufactures by Acclaim lighting. During the period specified above, Acclaim Lighting will replace defective parts at its expense, and will absorb all expenses for warranty service and repair labor by reason of defects in material or workmanship. The sole responsibility of Acclaim Lighting under this warranty shall be limited to the repair of the product, or replacement thereof, including parts, at the sole discretion of Acclaim Lighting. At no time will installation or re-installation or products labor or liability costs will be assumed by Acclaim Lighting. All products covered by this warranty were manufactured after January 1, 2012, and bear identifying serial number marks to that effect.

E. Acclaim Lighting reserves the right to make changes in design and/or improvements upon its products without any obligation to include these changes in any products theretofore manufactured. No warranty, whether expressed or implied, is given or made with respect to any accessory supplied with products describe above. Except to the extent prohibited by applicable law, all implied warranties made by Acclaim Lighting in connection with this product, including warranties of merchantability or fitness, are limited in duration to the warranty period set forth above. And no warranties, whether expressed or implied, including warranties of merchantability or fitness, shall apply to this product after said period has expired.

F. Marine or extreme weather location applications using Acclaim lighting products are subject to a 2 year limited warranty and Acclaim must be notified prior to delivery of units for such applications so that preventative treatment can be made to the products to ensure proper performance and product life with a special marine code coating / sealing process at an additional cost.

G. The consumer's and or dealer's sole remedy shall be such repair or replacement as is expressly provide above; and under no circumstances shall Acclaim Lighting be liable for any loss or damage, direct or consequential, arising out of the use of, or inability to use, this product. This warranty is the only written warranty applicable to Acclaim Lighting products and supersedes all prior warranties and written descriptions of warranty terms and conditions heretofore published.

www.acclaimlighting.com